



Diesel Generator Set



OPERATIONS AND SERVICE

For

69UG15

Generator Set Units

Tier 4 - UG2001 to UG2050 Series



OPERATIONS AND SERVICE

For

69UG15

Generator Set Units

Tier 4 - UG2001 to UG2050 Series

TABLE OF CONTENTS

PARAGRAPH NUMBER	Page
SAFETY SUMMARY	1-1
1.1 GENERAL SAFETY NOTICES	1-1
1.2 FIRST AID	1-1
1.3 OPERATING PRECAUTIONS	1-1
1.4 MAINTENANCE PRECAUTIONS	1-1
1.5 SPECIFIC HAZARD STATEMENTS	1-1
DESCRIPTION	2-1
2.1 INTRODUCTION	2-1
2.2 CONFIGURATION IDENTIFICATION	2-1
2.3 ENGINE	2-8
2.3.1 Electronic Governor Module	2-8
2.3.2 Engine Screw Threads	2-8
2.3.3 Engine Air System	2-8
2.3.4 Fuel System	2-8
2.3.5 Lube Oil Filter Arrangement	2-9
2.4 ALTERNATING CURRENT GENERATOR	2-9
2.5 BATTERY CHARGING SYSTEM	2-9
2.6 VOLTAGE CONTROLLER	2-9
2.7 OPERATING CONTROLS & INSTRUMENTS	2-9
2.7.1 Oil Pressure Gauge	2-9
2.7.2 Water Temperature Gauge	2-10
2.7.3 Auto Restart Module (Option)	2-10
2.7.4 Ammeter (A)	2-10
2.7.5 Total Time Meter (TT)	2-10
2.7.6 Intake Heater Switch (HS)	2-10
2.7.7 Ignition Switch (IGN)	2-10
2.7.8 Ignition Switch (IGN) with Auto Restart option	2-10
2.7.9 Intake Heater Timer (IHT)	2-10
2.7.10 Starter Solenoid Timer (SST)	2-10
2.8 SAFETY DEVICES	2-15
2.9 UNIT SPECIFICATIONS	2-17
2.10 ENGINE DATA	2-17
OPERATION	3-1
3.1 GENERATOR SET INSTALLATION	3-1
3.2 GENERATOR SET REMOVAL	3-1
3.3 STARTING AND STOPPING INSTRUCTIONS	3-4
3.3.1 Pre-Start Inspection	3-4
3.3.2 Starting Instructions	3-4
3.3.3 Post-Start Inspection	3-5
3.3.4 Stopping Instructions	3-5
3.4 SEQUENCE OF OPERATION WARNING	3-5

TROUBLESHOOTING	4-1
4.1 DIESEL ENGINE	4-1
4.1.1 Engine Will Not Start	4-1
4.1.2 Engine Starts Then Stops	4-2
4.1.3 Engine Will Not Shut Off	4-2
4.1.4 Starter Motor Malfunction	4-3
4.1.5 Malfunction In The Engine Starting Circuit	4-3
4.1.6 Miscellaneous Engine Troubleshooting	4-4
4.2 BATTERY CHARGER (SOLID STATE)	4-4
4.3 ALTERNATING CURRENT GENERATOR	4-5
4.4 AUTO RE-START OPTION	4-6
4.5 ELECTRONIC GOVERNOR MODULE	4-7
4.6 VOLTAGE CONTROLLER	4-7
4.7 HIGH VOLTAGE CIRCUIT	4-8
SERVICE AND PREVENTATIVE MAINTENANCE	5-1
5.1 INTRODUCTION	5-1
5.2 PREVENTATIVE MAINTENANCE SCHEDULE	5-1
5.3 BATTERY SERVICE	5-1
5.4 ENGINE SERVICE AND COMPONENTS	5-1
5.4.1 Bleeding the Fuel System	5-1
5.4.2 Servicing Fuel Pump Internal Filter	5-2
5.4.3 Fuel Filter	5-2
5.4.4 In-Line Fuel Strainer	5-2
5.4.5 Cooling System	5-2
5.4.6 Lube Oil Filter	5-3
5.4.7 Servicing the Low Coolant Sensor	5-3
5.4.8 Servicing Low Oil Pressure Switch	5-3
5.4.9 Engine Speed	5-4
5.4.10 Replacing the Engine Speed Sensor	5-4
5.4.11 Servicing Poly V-belt	5-4
5.4.12 Engine Air Cleaner	5-4
5.4.13 Engine Crankcase Breather	5-6
5.4.14 Intake Heater Test	5-7
5.4.15 Intake Heater Service	5-7
5.4.16 Intake Heater Switch (HS)	5-8
5.5 SERVICING THE AC GENERATOR	5-8
5.5.1 Remove and Replace Procedure	5-8
5.6 GENERAL GENERATOR SET MAINTENANCE	5-13
5.6.1 Maintenance of Painted Surfaces	5-13
5.6.2 Check and Replace Isolators / Shockmounts	5-13
5.7 UNIDRIVE TORQUE REQUIREMENTS	5-16
SCHEMATICS	6-1
6.1 INTRODUCTION	6-1
INDEX	INDEX-1

LIST OF ILLUSTRATIONS

FIGURE NUMBER	Page
Figure 2.1 Label with Generator Set Identification	2-1
Figure 2.2 Generator Set UniDrive View (PIDs prior to UG 2019)	2-2
Figure 2.3 Generator Set UniDrive View (PIDs UG2019 and Up)	2-3
Figure 2.4 Generator Set Front View (PIDs prior to UG2019)	2-4
Figure 2.5 Generator Set Front View (PIDs UG2019 and Up)	2-5
Figure 2.6 Generator Set Top View (PIDs prior to UG2019)	2-6
Figure 2.7 Generator Set Top View (PIDs UG2019 and Up)	2-7
Figure 2.8 Electronic Governor Module	2-8
Figure 2.9 Fuel System Diagram	2-8
Figure 2.10 Lube Oil	2-9
Figure 2.11 Control Panel and Control Box, Standard	2-11
Figure 2.12 Control Panel and Control Box, Auto Restart	2-12
Figure 2.13 Receptacle Box	2-13
Figure 3.1 Generator Set Mounting - Standard Mount	3-2
Figure 3.2 Generator Set Mounting - Quick Mount	3-3
Figure 5.1 Mechanical Fuel Pump	5-1
Figure 5.2 Low Coolant Sensor	5-3
Figure 5.3 Air Cleaner, Dry Element	5-5
Figure 5.4 Air Cleaner, Oil Bath	5-6
Figure 5.5 Engine Crankcase Breather	5-7
Figure 5.6 Intake Heater	5-7
Figure 5.7 Drive Gear	5-9
Figure 5.8 Generator R/R (PIDs prior to UG2019)	5-10
Figure 5.9 Generator R/R (PIDs UG2019 and Up)	5-10
Figure 5.10 Battery Charger (PIDs Prior to UG2019)	5-12
Figure 5.11 Battery Charger (PIDs UG2019 and Up)	5-12
Figure 5.12 Generator Shockmounts	5-14
Figure 5.13 Engine Shockmounts	5-15
Figure 5.14 Truss and Isolator	5-15
Figure 5.15 Unidrive Torque Requirements	5-16
Figure 5.16 Unidrive (with Torsional Dampener) Torque Requirements	5-17
Figure 6.1 Schematic Diagram - Legend (PIDs prior to UG2019)	6-1
Figure 6.2 Schematic Diagram (PIDs prior to UG2019)	6-2
Figure 6.3 Schematic High Voltage Circuitry (PIDs prior to UG2019)	6-3
Figure 6.4 Schematic Diagram - Legend (PIDs UG2019 and Up)	6-4
Figure 6.5 Schematic Diagram (PIDs UG2019 and Up)	6-5
Figure 6.6 Schematic High Voltage Circuitry - 7 Wire Generator (PID UG2019)	6-6
Figure 6.7 Schematic High Voltage Circuitry - 8 Wire Generator (PIDs UG2020 and Up)	6-7

LIST OF TABLES

TABLE NUMBER	Page
Table 2–2 Auto Restart Sequencing	2–14
Table 2–1 Auto Restart Preset Values	2–14
Table 2–3 Safety Devices	2–16
Table 4–1 Engine Will Not Start	4–1
Table 4–2 Engine Starts Then Stops	4–2
Table 4–3 Engine Will Not Shut Off	4–2
Table 4–4 Starter Motor Malfunction	4–3
Table 4–5 Malfunction In The Engine Starting Circuit	4–3
Table 4–6 Miscellaneous Engine Troubleshooting	4–4
Table 4–7 Battery Charger (Solid State)	4–4
Table 4–8 Alternating Current Generator	4–5
Table 4–9 Auto Re-Start Option	4–6
Table 4–10 Electronic Governor Modules	4–7
Table 4–11 Voltage Controller	4–7
Table 5–1 Preventative Maintenance Actions and Schedule	5–18

SECTION 1

SAFETY SUMMARY

1.1 General Safety Notices

Installation and servicing of Genset equipment can be hazardous due to system belts, radiator fan, and electrical components. Only trained and qualified service personnel should install, repair, or service Genset equipment. When working on Genset equipment, observe all potential Danger, Warning and Caution hazards, including those shown below and on hazard labels attached to the unit.

The following general safety notices supplement specific warnings and cautions appearing elsewhere in this manual. They are recommended precautions that must be understood and applied during operation and maintenance of the equipment covered herein. The general safety notices are presented in the following three sections labeled: First Aid, Operating Precautions and Maintenance Precautions. A listing of the specific warnings and cautions appearing elsewhere in the manual follows the general safety notices.

1.2 First Aid

An injury, no matter how slight, should never go unattended. Always obtain first aid or medical attention immediately.

1.3 Operating Precautions

Always wear safety glasses and hearing protection.

Keep hands, clothing and tools clear of the radiator fan and rotating belts.

Wear appropriate personal protective equipment for the work being undertaken.

No work should be performed on the unit until all circuit breakers and start-stop switches are turned off and the negative battery terminal has been disconnected.

Always work in pairs. Never work on the equipment alone.

In case of severe vibration or unusual noise, stop the unit and investigate.

1.4 Maintenance Precautions

Be sure power is turned off and the negative battery cable is disconnected before working on generator set.

Do not bypass any electrical safety devices, e.g. bridging an overload, or using any sort of jumper wires. Problems with the system should be diagnosed, and any necessary repairs performed, by qualified service personnel.

In case of electrical fire, open circuit switch and extinguish with CO₂ (never use water).

Fuel Tanks present explosion, fire, and rupture hazards even if liquid fuel has been drained. Do not attempt any repairs, especially repairs using flame, welder or torch, unless you have been properly trained and the tank has been emptied of liquid fuel and fuel vapors and the tank is properly ventilated.

1.5 Specific Hazard Statements

To help identify the hazard labels on the unit and explain the level of awareness each one carries, explanations with appropriate consequences are provided below:

DANGER - Indicates an immediate hazard which WILL result in severe personal injury or death.

WARNING - Indicates hazards or unsafe conditions which COULD result in severe personal injury or death.

CAUTION - Indicates potential hazards or unsafe practices which COULD result in minor personal injury, product, or property damage.

The statements that follow are applicable to the generator set and appear elsewhere in this manual. These recommended precautions must be understood and applied during operation and maintenance of the equipment covered herein.

 **WARNING**

Beware of moving poly V-belt, belt driven components and hot exhaust components.

 **WARNING**

Under no circumstances should ether or any other unauthorized starting aids be used in conjunction with the air intake heater.

 **WARNING**

Beware of moving poly V-Belt and belt driven components.

 **WARNING**

Beware of pinch points.

 **WARNING**

Do not use gasoline to clean air cleaner parts.

 **WARNING**

Do not direct water or steam into the generator openings. Do not allow any soap and water solutions to enter the alternator.

 **WARNING**

High voltage (dielectric) testing must not be performed to the machine without first observing NEMA rules. The insulation of this generator winding may be safely checked by using a megger. A high megger reading indicates good insulation.

 **CAUTION**

Observe proper polarity when installing the battery or connecting a battery charger, the negative battery terminal must be grounded. Reverse polarity may damage the charging system. When charging the battery in unit, isolate the battery by disconnecting the negative battery terminal first, then the positive. Once the battery has been charged, connect the positive battery terminal first, then the negative.

 **CAUTION**

Never pour cold water into a hot engine.

 **CAUTION**

Use only ethylene glycol, anti-freeze (with inhibitors) in system. Use of glycol by itself will damage the cooling system.

 **CAUTION**

Never open the radiator cap when the coolant is hot.

 **CAUTION**

Always cover the engine inlet tube while the air cleaner is being serviced.

 **CAUTION**

Do not underfill or overfill the oil bath cups. Overfilling of cups causes loss of capacity; underfilling cups causes lack of filtering efficiency.

 **CAUTION**

Continued operation with failed shockmounts may result in engine or generator damage.

SECTION 2

DESCRIPTION

2.1 Introduction

The Carrier Transicold model 69UG15 under-mounted diesel-driven generator set provides a constant electrical power supply for all-electric refrigeration units. This style unit is mounted to the frame rails of the container trailer chassis. The generator set consists of a diesel engine direct-connected to an alternating current generator and mounted in a structural steel frame.

Refer to the following illustrations for generator set component layout:

- UniDrive View (see [Figure 2.2](#), [Figure 2.3](#))
- Front View (see [Figure 2.4](#), [Figure 2.5](#))
- Top View (see [Figure 2.6](#), [Figure 2.7](#))

The engine is a vertical in-line, four cylinder diesel manufactured by Kubota. The generator is a 15 kW, brushless, dual bearing type that supplies nominal 50/60Hz power. Generator sets will start at 50Hz. Once the unit is running, the voltage controller will read the voltage output of the generator and adjust accordingly, to keep the voltage within ISO limits. As the Container becomes loaded, voltage drops and current increases, the generator set will switch windings or speed based on power demand and ambient conditions. The unit will typically run at 50Hz and will vary generator output via winding selection. The speed change to 60 Hz will typically occur when the ambient temperature is high and the unit is heavily loaded.

Electrical controls are mounted in a control box with operating controls and gauges mounted on a control panel, which also serves as the control box cover. The control panel components are protected by a deflector assembly and a windowed control box door.

The 69UG15 is available as a standard configuration, with an Auto Restart option or with Auto Restart and Low Coolant Sensor. The Auto Restart option automatically restarts the unit in the event of a unit shutdown. Auto Restart also offers built-in indicators that signal low oil pressure, high water temperature, overspeed, and other overcrank conditions.

Carrier Transicold's Ecodriven dual speed option provides an energy saving alternative to the practice of continuously running the generator at full speed. This speed reduction results in increased fuel economy, reduced carbon footprint, and lowers operating costs.

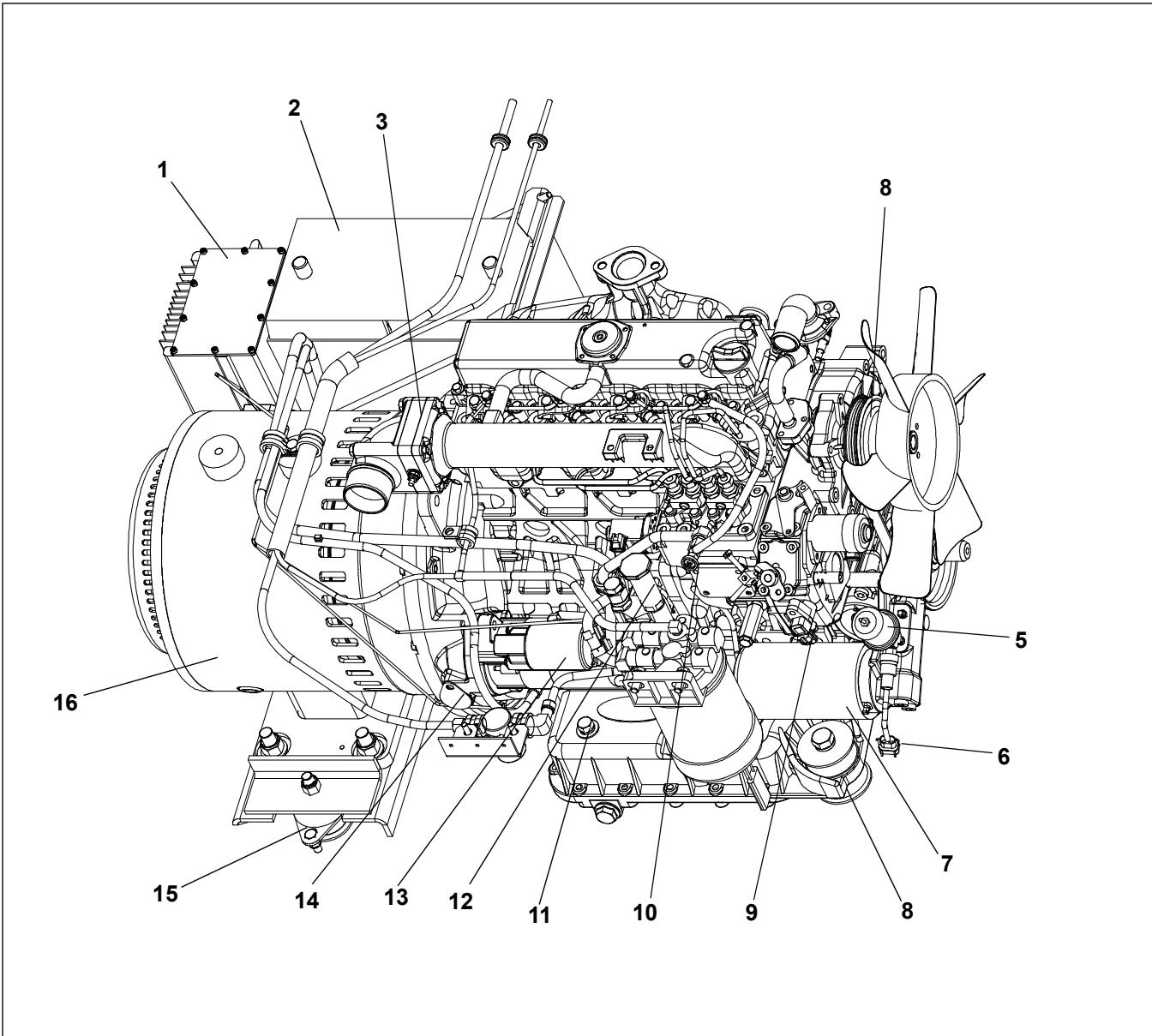
2.2 Configuration Identification

Generator set identification information is provided on a label (See Figure) located below the left mounting pad to the left of the access service door (front facing). The label provides the generator set model number, serial number, and parts identification number (PID). The model number identifies the overall configuration while the PID provides information on specific optional equipment and differences in detailed parts. The model number, serial number and PID number must be included when ordering parts and inquiring about your unit.

Figure 2.1 Label with Generator Set Identification

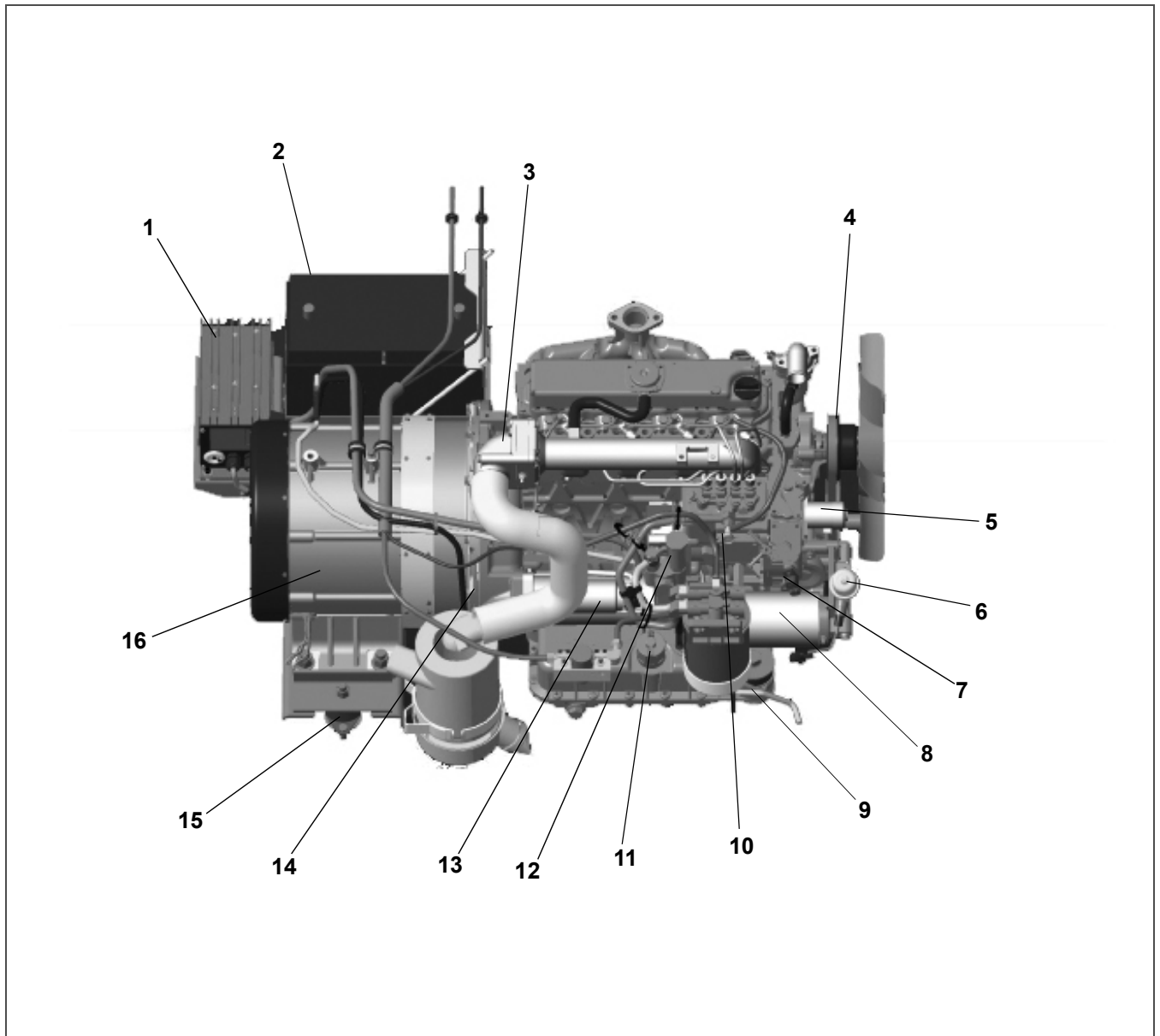


Figure 2.2 Generator Set UniDrive View (PIDs prior to UG 2019)



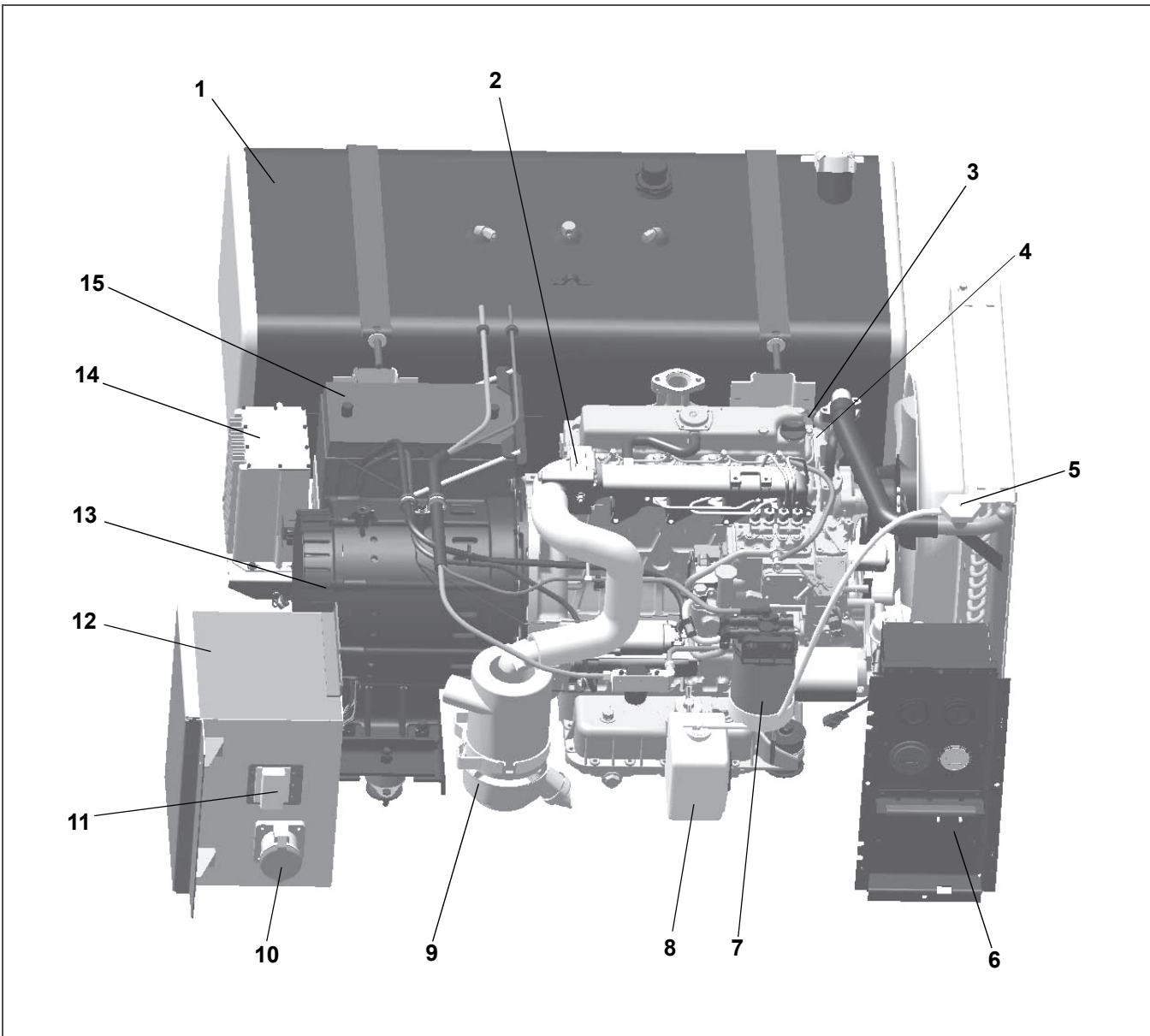
- | | |
|------------------------|----------------------------------|
| 1) Battery Charger | 9) Engine Speed Sensor |
| 2) Battery | 10) Injector Pump |
| 3) Intake Air Heater | 11) Lube Oil Dipstick / Fuel Cap |
| 4) V-Belt | 12) Mechanical Fuel Pump |
| 5) Oil Pressure Sender | 13) Starter |
| 6) Oil Pressure Switch | 14) Flywheel Access Cover |
| 7) Oil Filter | 15) Generator Shockmount |
| 8) Engine Shockmount | 16) Generator |
-

Figure 2.3 Generator Set UniDrive View (PIDs UG2019 and Up)



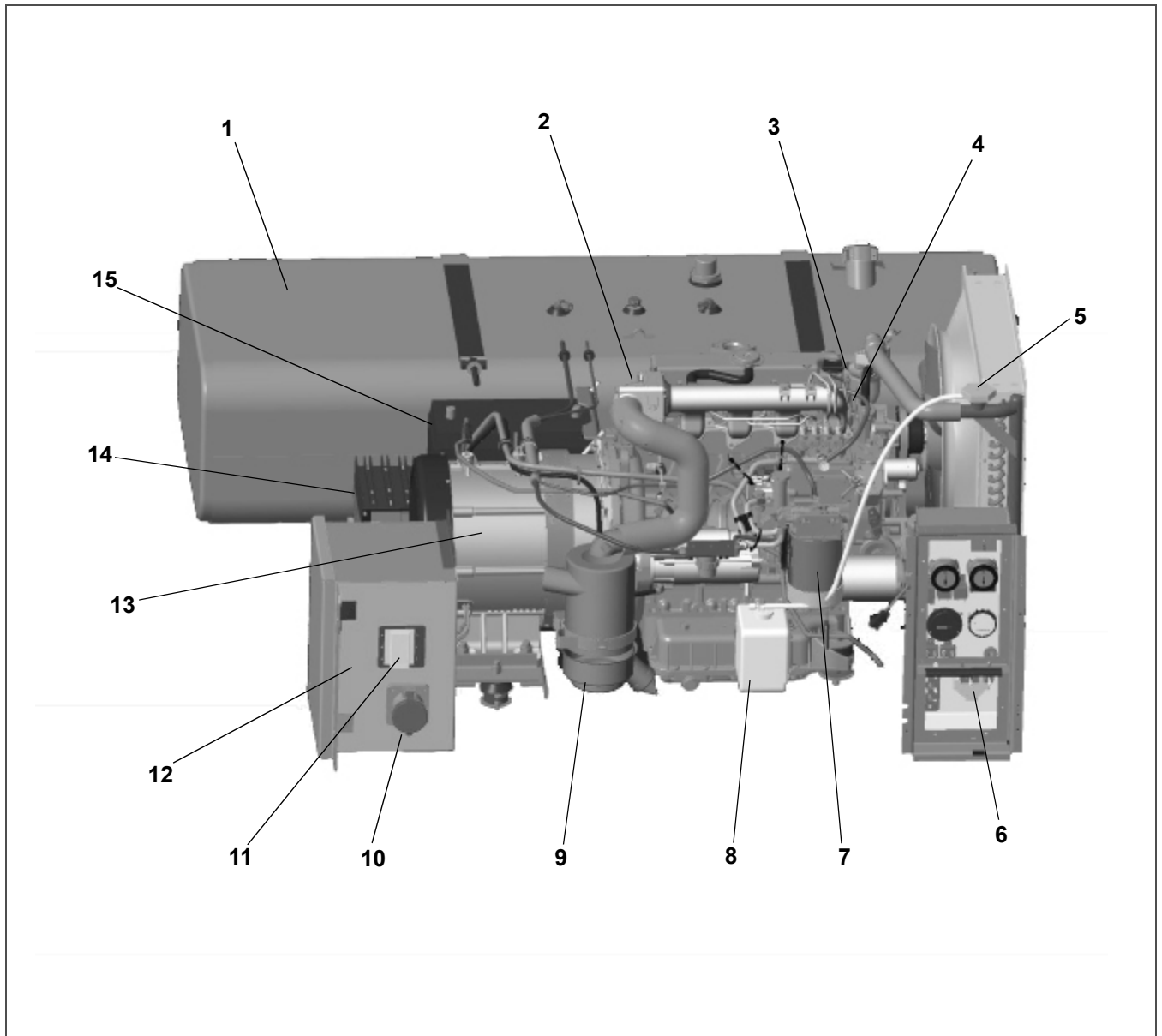
- | | |
|------------------------|----------------------------------|
| 1) Battery Charger | 9) Engine Shockmount |
| 2) Battery | 10) Injector Pump |
| 3) Intake Air Heater | 11) Lube Oil Dipstick / Fuel Cap |
| 4) V-Belt | 12) Mechanical Fuel Pump |
| 5) Oil Pressure Sender | 13) Starter |
| 6) Oil Pressure Switch | 14) Flywheel Access Cover |
| 7) Engine Speed Sensor | 15) Generator Shockmount |
| 8) Oil Filter | 16) Generator |

Figure 2.4 Generator Set Front View (PIDs prior to UG2019)



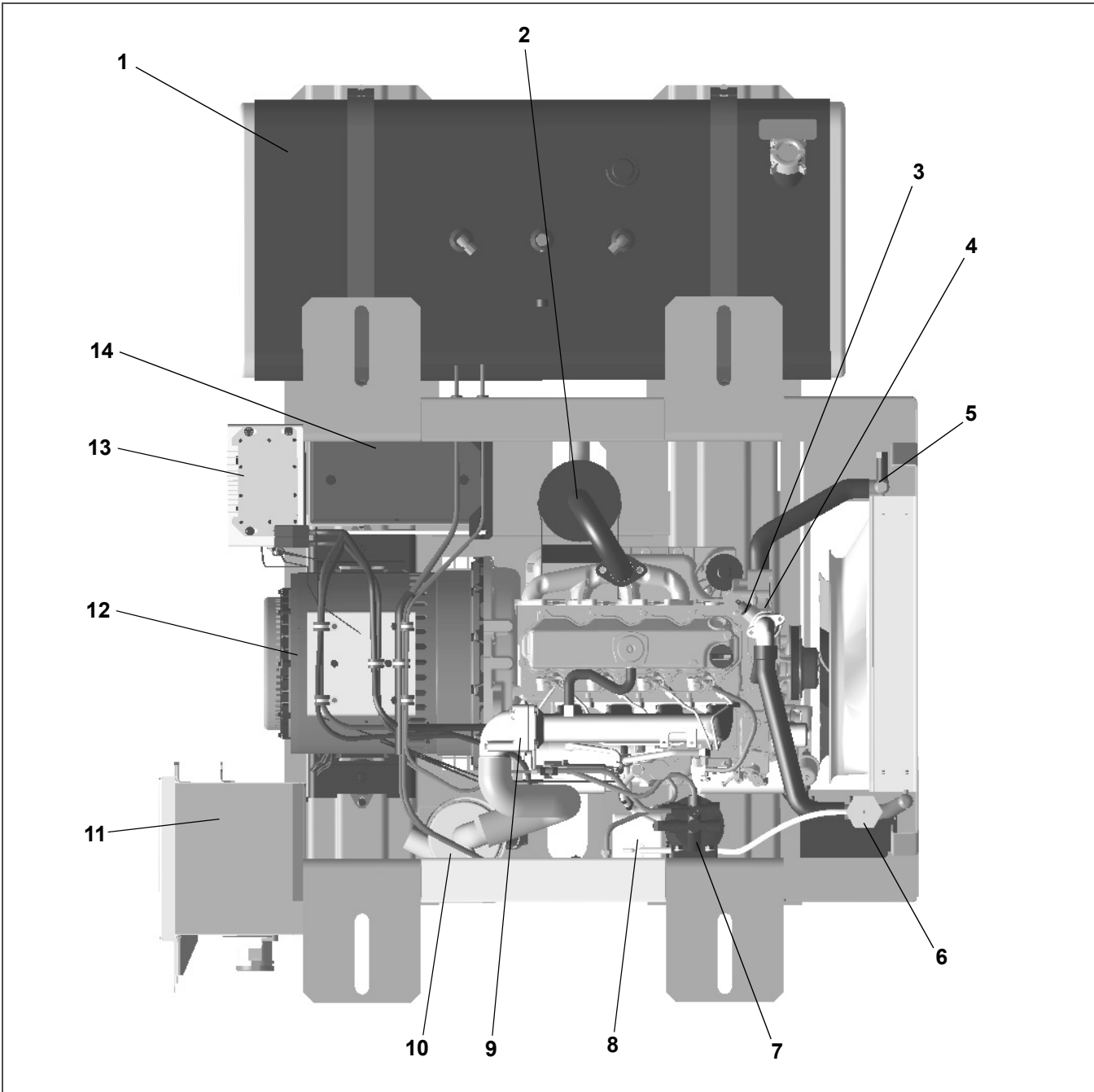
- | | |
|------------------------------|---------------------|
| 1) Fuel Tank | 9) Air Cleaner |
| 2) Intake Air Heater | 10) Receptacle |
| 3) Water Temperature Switch | 11) Circuit Breaker |
| 4) Water Temperature Sensor | 12) Receptacle Box |
| 5) Radiator | 13) Generator |
| 6) Controls | 14) Battery Charger |
| 7) Fuel Filter / Fuel Heater | 15) Battery |
| 8) Coolant Overflow Bottle | |

Figure 2.5 Generator Set Front View (PIDs UG2019 and Up)



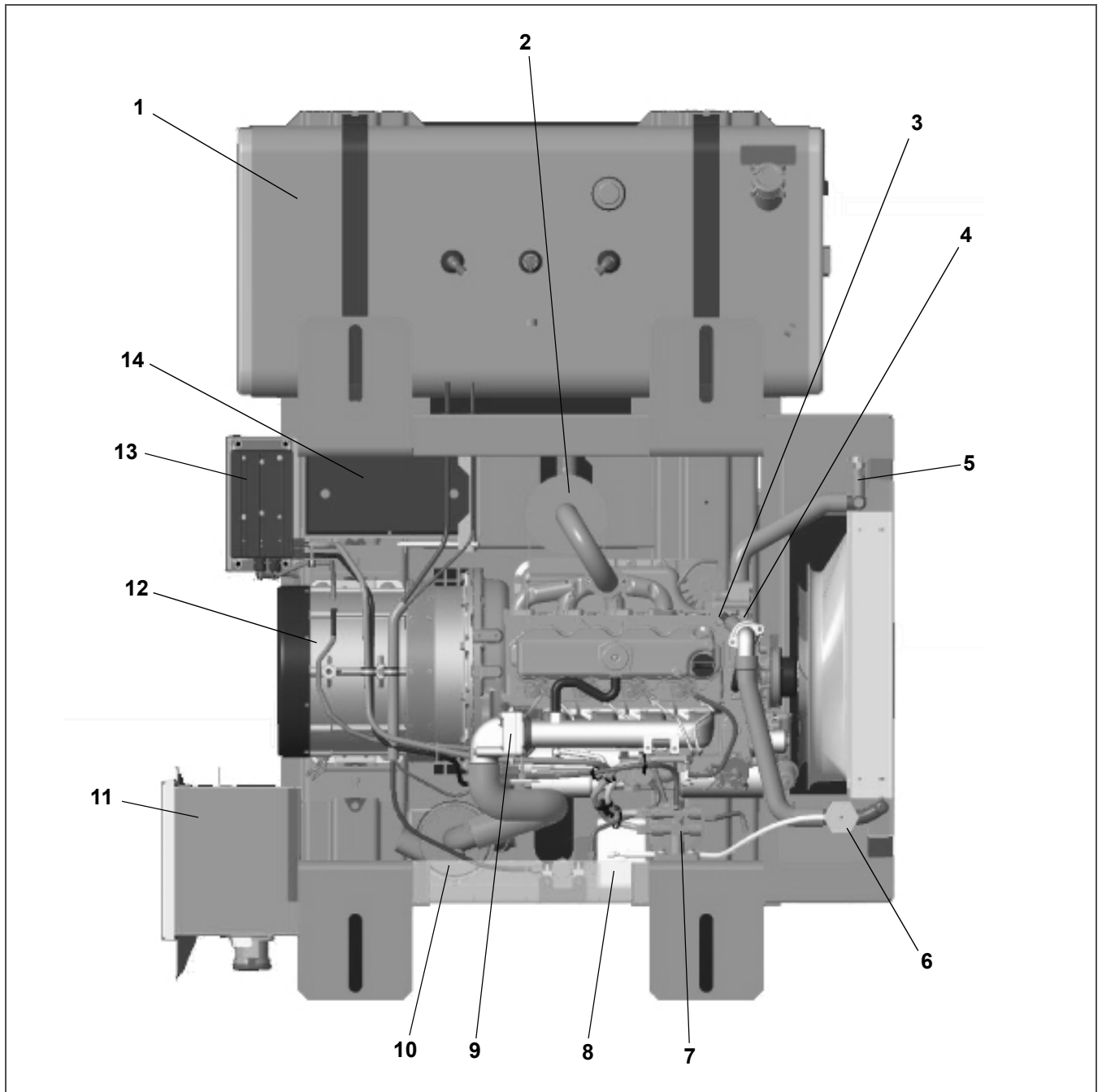
- | | |
|------------------------------|---------------------|
| 1) Fuel Tank | 9) Air Cleaner |
| 2) Intake Air Heater | 10) Receptacle |
| 3) Water Temperature Switch | 11) Circuit Breaker |
| 4) Water Temperature Sensor | 12) Receptacle Box |
| 5) Radiator | 13) Generator |
| 6) Controls | 14) Battery Charger |
| 7) Fuel Filter / Fuel Heater | 15) Battery |
| 8) Coolant Overflow Bottle | |

Figure 2.6 Generator Set Top View (PIDs prior to UG2019)



- | | |
|------------------------------|----------------------------|
| 1) Fuel Tank | 8) Coolant Overflow Bottle |
| 2) Muffler | 9) Intake Air Heater |
| 3) Water Temperature Switch | 10) Air Cleaner |
| 4) Water Temperature Sensor | 11) Receptacle Box |
| 5) Low Coolant Sensor | 12) Generator |
| 6) Radiator | 13) Battery Charger |
| 7) Fuel Filter / Fuel Heater | 14) Battery |

Figure 2.7 Generator Set Top View (PIDs UG2019 and Up)



- | | |
|------------------------------|----------------------------|
| 1) Fuel Tank | 8) Coolant Overflow Bottle |
| 2) Muffler | 9) Intake Air Heater |
| 3) Water Temperature Switch | 10) Air Cleaner |
| 4) Water Temperature Sensor | 11) Receptacle Box |
| 5) Low Coolant Sensor | 12) Generator |
| 6) Radiator | 13) Battery Charger |
| 7) Fuel Filter / Fuel Heater | 14) Battery |

2.3 Engine

The engine is a vertical, in-line four cylinder diesel engine, which is directly connected to the alternating current generator. Information on the major engine systems is provided in the following sub-paragraphs.

Auxiliary engine equipment consists of the battery, solid state battery charging system, "spin-on" lube oil filter, fuel filter and other necessary components for proper unit operation. The water pump and the radiator cooling fan are belt-driven from the engine crankshaft. All references to engine are as viewed from the fly wheel end.

Separately bound manuals covering the diesel engine are available:

- 62-10865, V2203-DI Engine Workshop
- 62-11695, V2203-DI Engine Parts List

2.3.1 Electronic Governor Module

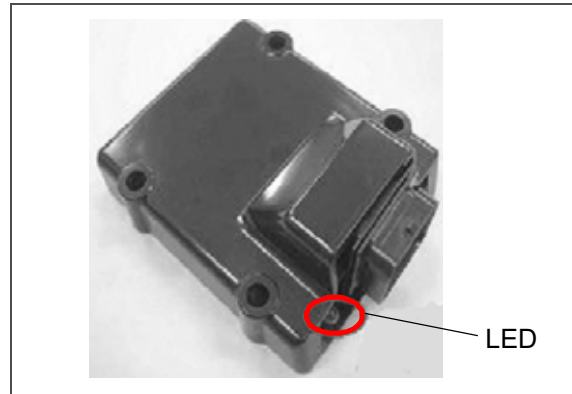
The Electronic Governor (EG) module ([Figure 2.8](#)) is a solid state control module pre-programmed for 1800 RPM high speed and 1500 RPM low speed operation.

The EG unit has an LED which may be used to diagnose failures within the electronic speed control system, refer to [Section 4.5](#) for additional troubleshooting information on diagnosing failures.

2.3.2 Engine Screw Threads

All threads used on the engine are metric except for the oil drain plug, which is American Standard Pipe Thread (NPT).

Figure 2.8 Electronic Governor Module



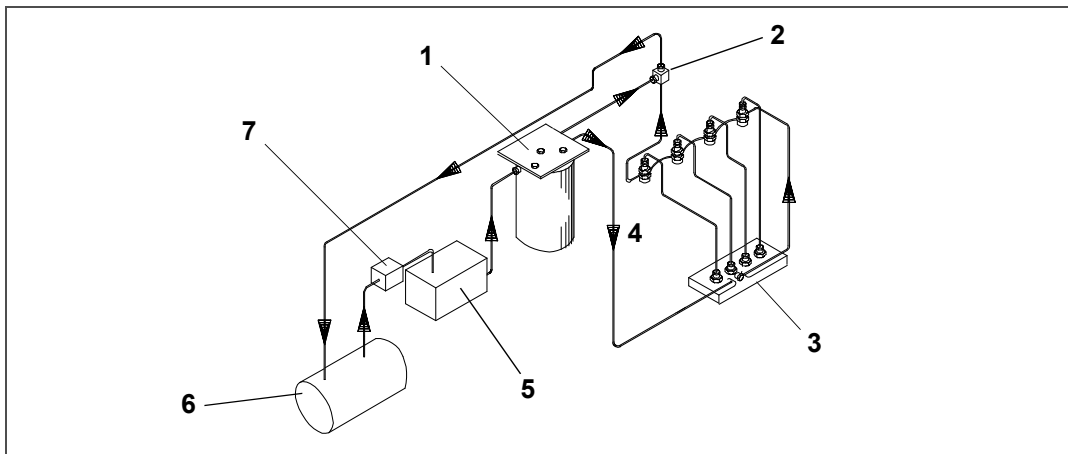
2.3.3 Engine Air System

The air cleaner is designed to prolong engine life and performance by preventing dirt and grit from entering the engine and causing excessive wear on all operating parts. In order for the air filter to operate properly, the operator must regularly maintain the air cleaner equipment in accordance with the instructions provided within this document.

2.3.4 Fuel System

The fuel system is fitted with an in-line fuel strainer and a fuel filter, which also acts as a water separator. The fuel system is shown in [Figure 2.9](#). The fuel heater system is located in the fuel filter and uses a 12 volt heater to heat fuel as it passes through the fuel filter, see [Figure 2.9](#).

Figure 2.9 Fuel System Diagram

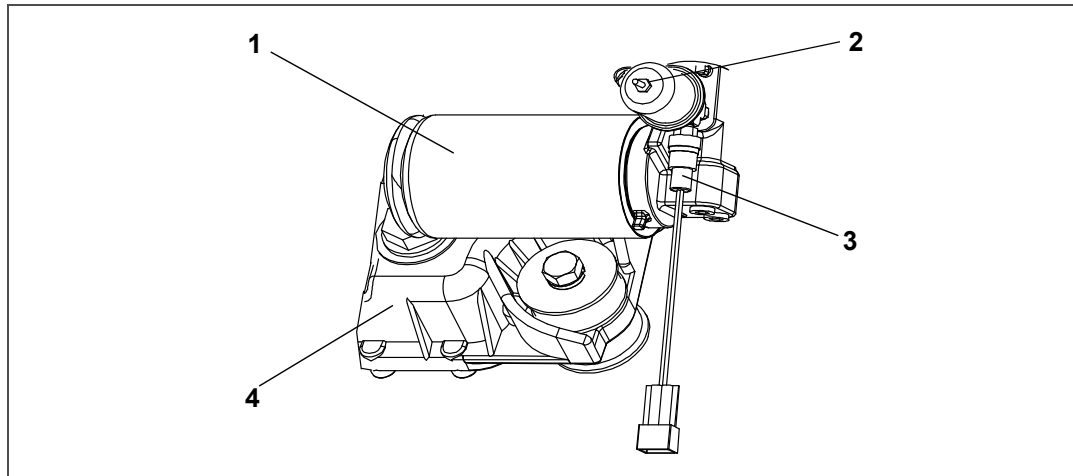


- | | |
|-------------------------|-----------------------------------|
| 1) Fuel Filter / Heater | 5) Mechanical Lift Pump |
| 2) Injector Nozzles | 6) Fuel Tank |
| 3) Bleed Valve | 7) In-Line Fuel Strainer (option) |
| 4) Injection Pump | |

2.3.5 Lube Oil Filter Arrangement

The engine lubricating oil filter is mounted in a horizontal arrangement and shown in [Figure 2.10](#).

Figure 2.10 Lube Oil



- | | |
|-------------------------|------------------------|
| 1) Oil Filter (Primary) | 3) Oil Pressure Switch |
| 2) Oil Pressure Sender | 4) Oil Pan |

2.4 Alternating Current Generator

The generator is directly bolted to the engine and supplies nominal 50/60Hz power depending on the load requirement.

2.5 Battery Charging System

The solid state battery charger is located in front of the battery. The battery charger is powered by the generator, and this input is protected by fuses located in the receptacle box. The battery charger produces a tapered charge (40 amps maximum) and is designed not to overcharge the battery.



Observe proper polarity when installing the battery or connecting a battery charger. The negative battery terminal must be grounded. Reverse polarity may damage the charging system. When charging the battery in unit, isolate the battery by disconnecting the negative battery terminal first, then the positive. Once the battery has been charged, connect the positive battery terminal first, then the negative.

2.6 Voltage Controller

Voltage Controller maintains ISO voltage via two-speed and dual winding control. It is used to regulate voltage in order to keep the generator output within ISO limits:

- 50Hz - 1500 RPM, 360 - 460 VAC
- 60Hz - 1800 RPM, 400 - 500 VAC

2.7 Operating Controls & Instruments

Components required for monitoring and controlling the Genset unit are located in the control box, on the control panel and on the receptacle box.

2.7.1 Oil Pressure Gauge

The Oil Pressure Gauge (see [Figure 2.11](#), [Figure 2.12](#)) observes normal operating engine oil pressure. Normal oil pressure is 35 to 60 psig (3.3 to 5.2 kg/cm²). The Oil Pressure Sender (see [Figure 2.10](#)), located at the oil filter housing, senses lube oil pressure and transmits a signal to the Oil Pressure Gauge.

2.7.2 Water Temperature Gauge

The Water Temperature Gauge (see [Figure 2.11](#), [Figure 2.12](#)) observes water operating temperature. Once the unit has achieved normal running temperature, the coolant temperature is between 82 - 96°C (180 - 205°F). The Water Temperature Sensor senses engine water temperature and transmits a signal to the Water Temperature Gauge.

2.7.3 Auto Restart Module (Option)

The Auto Start / Restart module (see [Figure 2.12](#)) is provided to simplify the start-up process and provide an automatic restart feature that will automatically attempt to restart the unit in the event of shutdown. Four LEDs are used to indicate shutdown from overcrank, overspeed, low oil pressure, and high water temperature. A fifth LED is used to indicate the unit is running. Refer to [Table 2-1](#) for system Auto Start preset values.

The Auto Restart function will perform a series of six attempts to restart the unit and make three attempts within each series. Once the function has completed all 18 attempts, the unit will automatically lock out future crank attempts. Refer to [Table 2-2](#) for detailed information on Auto Restart sequencing.

A Low Coolant Sensor senses the coolant level inside the radiator and will complete a conductive circuit as long as the probes remain immersed in coolant. When coolant level falls below the probes, a signal is sent to the Auto Restart Module, shutting down the engine and all 12-volt circuitry.

2.7.4 Ammeter (A)

The Ammeter (see [Figure 2.11](#), [Figure 2.12](#)) indicates the rate of charge or discharge of the battery charging system. The battery charging system is composed of the battery and the battery charger, either solid state or alternator. During start up, the intake heater draws approximately 42 amps.

2.7.5 Total Time Meter (TT)

The Total Time Meter (see [Figure 2.11](#), [Figure 2.12](#)) calculates the total hours the unit has been running, which provides an accurate readout of accumulated engine running time. This data can be used to establish proper maintenance schedules (refer to [Table 5-1](#)).

2.7.6 Intake Heater Switch (HS)

The Intake Heater Switch (HS) (see [Figure 2.11](#)) is a momentary switch. When held in the PREHEAT position, the switch allows approximately 42 amps of battery current to flow into the intake heater, which preheats the air within the intake manifold and allows the engine to start. After starting the engine, the intake heater switch should continue to be held in the ON position for approximately 5 seconds until the engine has developed enough oil pressure to close the oil pressure safety switch.

2.7.7 Ignition Switch (IGN)

The Ignition Switch (IGN) (see [Figure 2.11](#)) is a momentary switch that has OFF/ON/START positions. When held in the START (ignition) position, it energizes the starter motor solenoid, which in turn allows the starter motor to crank the engine. The switch is released to the RUN position once the engine has started.

2.7.8 Ignition Switch (IGN) with Auto Restart option

The Ignition Switch (IGN) (see [Figure 2.12](#)) is a maintained contact switch that has the RUN/OFF positions. When switched to the RUN position, it energizes the control module, which in turn controls all functions of the Genset.

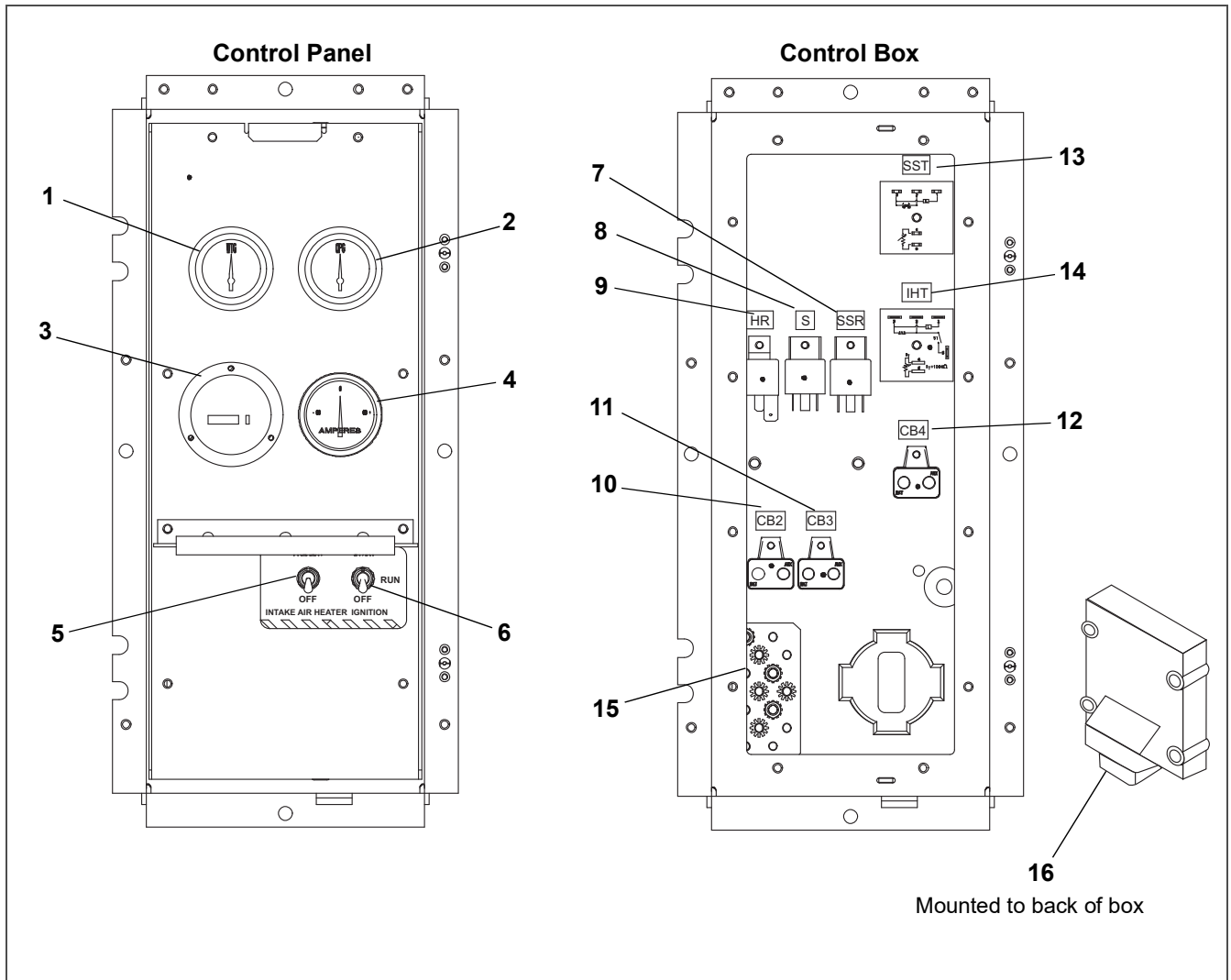
2.7.9 Intake Heater Timer (IHT)

The Intake Heater Timer (if equipped) (see [Figure 2.11](#)) continues to supply power to the intake heater for 3 minutes after initial start-up.

2.7.10 Starter Solenoid Timer (SST)

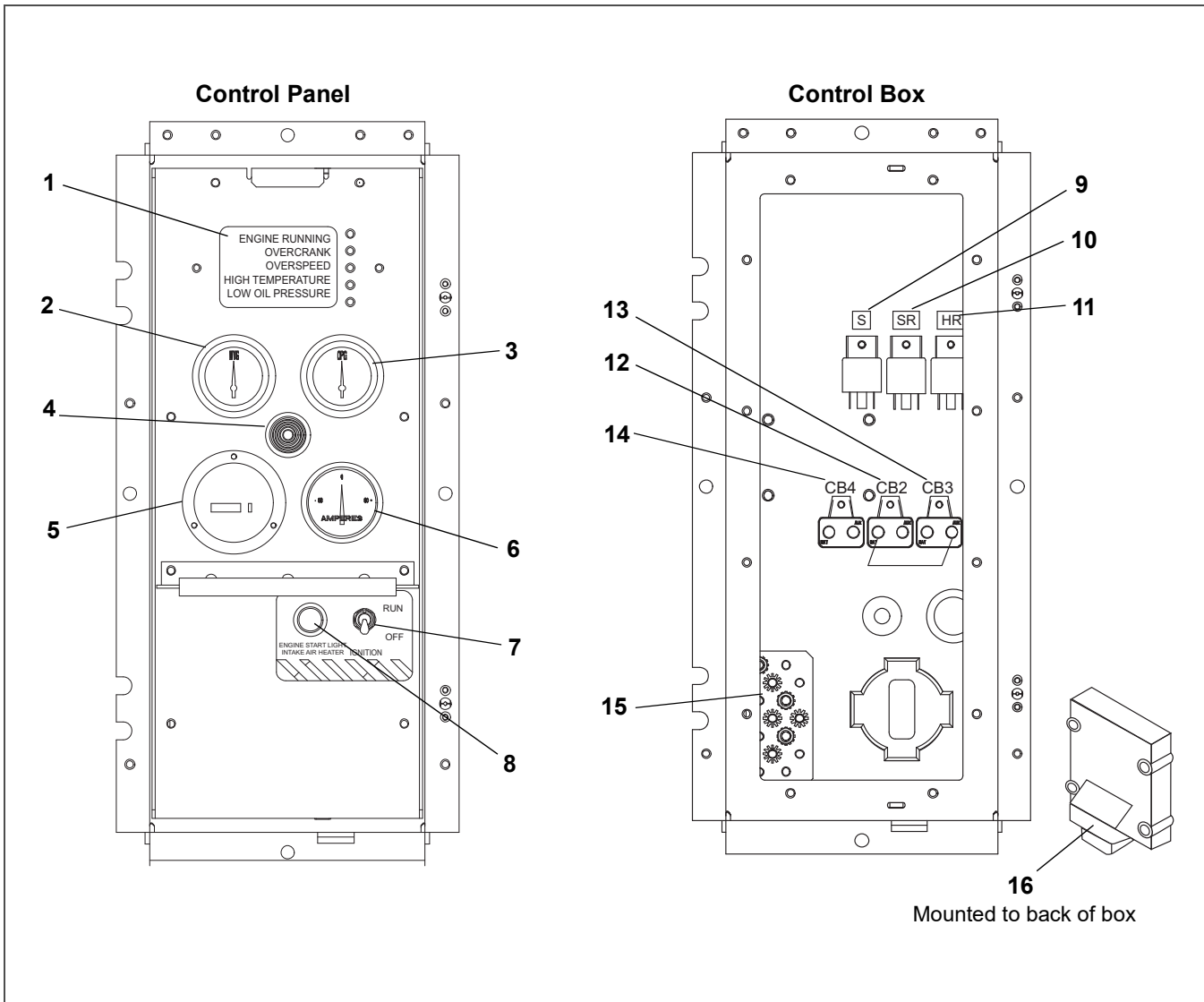
The Starter Solenoid Timer (SST) (see [Figure 2.11](#)) limits the amount of time that the starter can be engaged to 15 seconds. If the starter is manually engaged for more than 15 seconds, power will be cut to the starter. Once power has been removed, the starter can again be engaged for up to 15 seconds.

Figure 2.11 Control Panel and Control Box, Standard



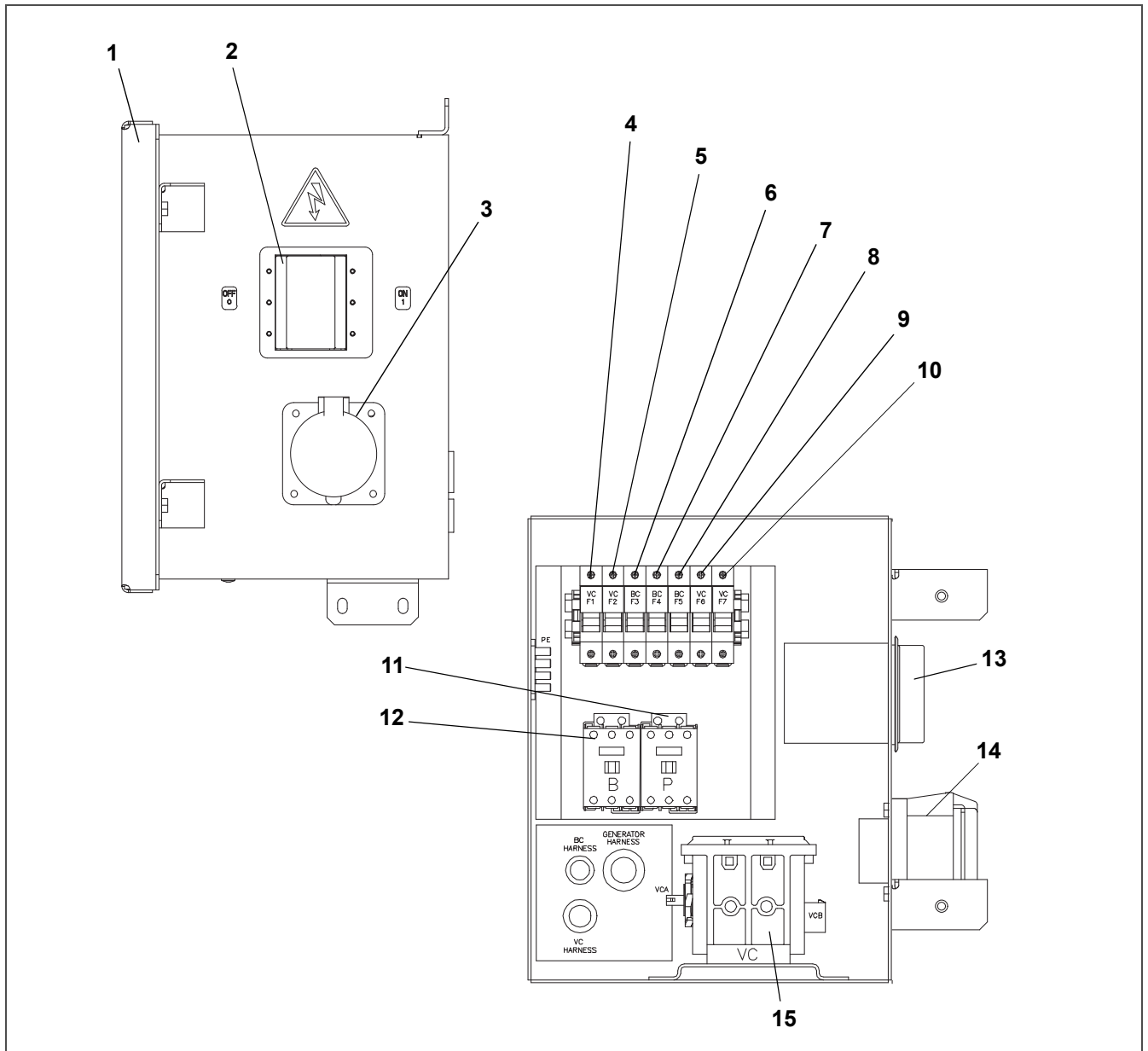
- | | |
|---------------------------------|-------------------------------------|
| 1) Water Temperature Gauge | 9) Intake Heater Relay (HR) |
| 2) Oil Pressure Gauge | 10) Circuit Breaker (CB2) |
| 3) Total Time Meter (TT) | 11) Circuit Breaker (CB3) |
| 4) Ammeter (A) | 12) Circuit Breaker (CB4) |
| 5) Intake Heater Switch (HS) | 13) Starter Solenoid Timer (SST) |
| 6) Ignition Switch (IGN) | 14) Intake Heater Timer (IHT) |
| 7) Starter Solenoid Relay (SSR) | 15) Ground Studs |
| 8) Safety Relay (S) | 16) Electronic Governor Module (EG) |

Figure 2.12 Control Panel and Control Box, Auto Restart



- | | |
|---------------------------------------|-------------------------------------|
| 1) Auto Restart Module | 9) Safety Relay (S) |
| 2) Water Temperature Gauge | 10) Starter Relay (SR) |
| 3) Oil Pressure Gauge | 11) Intake Heater Relay (HR) |
| 4) Engine Start Alarm (Buzzer) | 12) Circuit Breaker (CB2) |
| 5) Total Time Meter (TT) | 13) Circuit Breaker (CB3) |
| 6) Ammeter (A) | 14) Circuit Breaker (CB4) |
| 7) Ignition Switch (IGN) | 15) Ground Studs |
| 8) Engine Start / Intake Heater Light | 16) Electronic Governor Module (EG) |

Figure 2.13 Receptacle Box



- 1) Access Cover
- 2) Circuit Breaker (CB1) Genset
- 3) Receptacle
- 4) VCF1, Fuse 1
- 5) VCF2, Fuse 2
- 6) BCF3, Fuse 3
- 7) BCF4, Fuse 4
- 8) BCF5, Fuse 5

- 9) VCF6, Fuse 6
- 10) VCF7, Fuse 7
- 11) Primary Contactor
- 12) Boost Contactor
- 13) Circuit Breaker (CB1) Genset
- 14) Receptacle
- 15) Voltage Contactor

Table 2–1 Auto Restart Preset Values

Indicator	Preset Value	Description
Overspeed	2100 RPM	Overspeed is the point at which the unit will signal for shutdown
Crank Disconnect	700 RPM	Crank Disconnect is the point at which the auto restart module senses the engine has started and will disengage the starter
Shutdown Lockout Delay	15 seconds	The oil pressure and water temperature inputs are ignored during this 15 second delay (after start up)
Intake Heater Delay	30 seconds preheat 3 minutes postheat	The delay is used during start up. The intake heater delay begins timing after the auto restart module signal is received. During the entire delay, the intake heater circuit will be energized, an indicator light will be illuminated, and an alarm will sound. When the delay expires, the unit will crank.
Crank Attempts	18 attempts	A series of six attempts with three attempts in each series (total of 18 attempts)

Table 2–2 Auto Restart Sequencing

*Engine crank and rest is repeated three times each series unless the engine starts.		
Series Attempt Number	1	Engine Status: If the engine starts: 1. Run sequence begins 2. Intake heater remains energized for 3 minutes If the engine fails to start: 1. Intake heater will de-energize. 2. Fuel solenoid will de-energize. 3. Crank output will de-energize. 4. Overcrank LED will flash once. Wait two seconds and repeat. 5. Unit will rest 30 minutes and proceed to the next series.
Intake Heater Energized (Seconds)	30	
Fuel Solenoid Engaged	Yes	
Engine Crank Duration (Seconds)	Up to 15	
Engine Rest Duration (Seconds)	25	
Series Attempt Number	2	Engine Status: If the engine starts: 1. Run sequence begins 2. Intake heater remains energized for 3 minutes If the engine fails to start: 1. Intake heater will de-energize. 2. Fuel solenoid will de-energize. 3. Crank output will de-energize. 4. Overcrank LED will flash twice. Wait two seconds and repeat. 5. Unit will rest 30 minutes and proceed to the next series.
Intake Heater Energized (Seconds)	30	
Fuel Solenoid Engaged	Yes	
Engine Crank Duration (Seconds)	Up to 15	
Engine Rest Duration (Seconds)	25	
Series Attempt Number	3	Engine Status: If the engine starts: 1. Run sequence begins. If the engine fails to start: 1. Intake heater will de-energize. 2. Fuel solenoid will de-energize. 3. Crank output will de-energize. 4. Overcrank LED will flash three times. Wait two seconds and repeat. 5. Unit will rest five hours and proceed to the next series.
Intake Heater Energized (Seconds)	30	
Fuel Solenoid Engaged	Yes	
Engine Crank Duration (Seconds)	Up to 15	
Engine Rest Duration (Seconds)	25	

Table 2–2 Auto Restart Sequencing

Series Attempt Number	4	Engine Status: If the engine starts: 1. Run sequence begins. If the engine fails to start: 1. Intake heater will de-energize. 2. Fuel solenoid will de-energize. 3. Crank output will de-energize. 4. Overcrank LED will flash four times. Wait two seconds and repeat. 5. Unit will rest five hours and proceed to the next series.
Intake Heater Energized in Seconds	30	
Fuel Solenoid Engaged	Yes	
Engine Crank Duration (Seconds)	Up to 15	
Engine Rest Duration (Seconds)	25	
Series Attempt Number	5	Engine Status: If the engine starts: 1. Run sequence begins. If the engine fails to start: 1. Intake heater will de-energize. 2. Fuel solenoid will de-energize. 3. Crank output will de-energize. 4. Overcrank LED will flash five times. Wait two seconds and repeat. 5. Unit will rest five hours and proceed to the next series.
Intake Heater Energized (Seconds)	30	
Fuel Solenoid Engaged	Yes	
Engine Crank Duration (Seconds)	Up to 15	
Engine Rest Duration (Seconds)	25	
Series Attempt Number	6	Engine Status: If the engine starts: 1. Run sequence begins. If the engine fails to start: 1. Intake heater will de-energize. 2. Fuel solenoid will de-energize. 3. Crank output will de-energize. 4. Overcrank LED will illuminate solid and lock out future crank attempts. 5. To reset, turn unit power switch OFF and back ON..
Intake Heater Energized (Seconds)	30	
Fuel Solenoid Engaged	Yes	
Engine Crank Duration (Seconds)	Up to 15	
Engine Rest Duration (Seconds)	25	

2.8 Safety Devices

Safety devices, such as circuit breakers, fuses, and safety switches protect system components from damage.

The AC generator, solid state battery charger, fuel heater, high water temperature, safety relay, total time meter and intake heater are protected by circuit breakers. If a safety device opens and there is an interruption of electrical current, the electronic governor module will be de-energized, which will also de-energize the fuel solenoid, interrupt the fuel flow to the engine and stop the engine.

In units with auto restart, the engine, engine control devices, and engine monitoring devices are protected by the auto restart module, low coolant sensor (if equipped), circuit breaker, low oil pressure switch, and high water temperature switch. These safety devices monitor system operating conditions and open a set of electrical contacts when an unsafe condition occurs. If a safety device opens and there is an interruption of electrical current, the electronic governor module will be de-energized, which will also de-energize the fuel solenoid, interrupt the fuel flow to the engine and stop the engine.

De-energizing the fuel solenoid shuts off the fuel supply to the engine; thus stopping the engine. Safety device specifications are provided in [Table 2–3](#).

Table 2-3 Safety Devices

Engine		
Unsafe Condition:	Low engine lubricating oil pressure	
	Safety Switch	Low oil pressure switch (LOP) - Automatic reset
	Switch Setting	Opens below 18 psig (1.27 kg/cm)
Unsafe Condition:	High engine cooling water temperature	
	Safety Switch	Water temperature switch (HWT) - Automatic reset
	Switch Setting	Opens at 110°C (230°F)
Unsafe Condition:	Excessive current draw by the safety relay, fuel heater, water temperature gauge, oil pressure gauge or total time meter	
	Safety Switch	Circuit breaker (CB-2) - Automatic reset
	Switch Setting	Trips at 30 amps
Unsafe Condition:	Excessive current draw by the electronic governor module	
	Safety Switch	Fuse 1, 2, 3 (replace)
	Switch Setting	Trips at 10 amps
Intake Heater		
Unsafe Condition:	Excessive current draw on intake heater circuit	
	Safety Switch	Circuit breaker (CB-3) - Automatic reset
	Switch Setting	Trips at 50 amps
Battery Charger		
Unsafe Condition:	Excessive current draw on 12 volt supply circuit.	
	Safety Switch	Circuit breaker (CB-4) - Automatic reset
	Switch Setting	Trips at 50 amps
Unsafe Condition:	Excessive current draw on 460 volt feed circuit	
	Safety Switch	Fuses BCF3, BCF4, BCF5 (replace)
	Switch Setting	Trips at 5 amps
Generator		
Unsafe Condition:	Excessive current draw by load	
	Safety Switch	Circuit breaker (CB1, 460 volt) - Manual reset
	Switch Setting	Trips at 26 amps (460 vac)
Voltage Controller		
Unsafe Condition:	Excessive current draw on 460 volt feed circuit	
	Safety Switch	Fuses VCF1, VCF2, VCF6, VCF7 (replace)
	Switch Setting	Trips at 5 amps

2.9 Unit Specifications

Fuel Tanks		
	Nominal Tank Sizes	50 Gallon Steel
	Fill Capacity	52 Gallons (197 liters)
	Draw Capacity	50 Gallons (189 liters)
	Nominal Tank Sizes	50 Gallon Aluminum
	Fill Capacity	52 Gallons (197 liters)
	Draw Capacity	50 Gallons (189 liters)
	Nominal Tank Sizes	65 Gallon Steel
	Fill Capacity	67.5 Gallons (256 liters)
	Draw Capacity	65 Gallons (246 liters)
	Nominal Tank Sizes	80 Gallon Aluminum
	Fill Capacity	85 Gallons (322 liters)
	Draw Capacity	80 Gallons (303 liters)
Weights		
	Battery	63 lb (28.6 kg)
	Generator (A-C)	197 lb (89 kg)
	Engine (Dry) - without Accessories	439 lb (199 kg) approximate
	Unit (with 50 gallon steel tank, dry)	-
	Unit (with 50 gallon aluminum tank, dry)	-
	Unit (with 65 gallon steel tank, dry)	1555lb (705 kg)
	Unit (with 80 gallon aluminum tank, dry)	

2.10 Engine Data

Bore /Stroke:	3.26 in. (83 mm) / 4.03 in. (102.4 mm)
Compression Ratio:	22.0 to 1
Cylinders (Number):	Four
Displacement:	135.2 cubic inches (2.22 liters) (2216 cm ³)
Firing Order:	1-3-4-2

Lubrication System:	Oil Pressure Safety Switch Setting Opens	18 psig (1.27 kg/cm ²)
	Capacity	Engine - 15.0 US quarts (14.2 liters), includes standard filter.
	Oil Level Indicator	Dipstick in oil pan or fill cap NOTE: To check oil level on engines with the dipstick mounted in the fill cap, remove the cap and wipe the dipstick clean. Insert the cap back onto the oil fill tube, then remove to check level. It is not necessary to screw the cap back into the fill tube when checking level. DO NOT add oil if level is within the "safe" range. If needed, add oil to bring level within the "safe" range. Screw cap fully into fill tube after checking level.
	Lube Oil Specification	Use a heavy duty lubricating oil conforming to American Petroleum Institute (API) Service Classification CF or better.
	Lube Oil Viscosity	Outdoor Temperature Fahrenheit: 0°F to 45°F Centigrade: -18°C to 7°C SAE: 10W30 or Mobile Delvac 1* Fahrenheit: 45°F and above Centigrade: 7°C and above SAE: 10W30 or 15W40 or Mobile Delvac 1* * Mobile Delvac 1, 5W-40 or 15W-40 is the only approved synthetic oil.
Fuel and Fuel Heater Thermostat (FHT):		
Fuel	Winter	Diesel No. 2 with winter blends
	Summer	Diesel No. 2
FHT	Winter	Close on temperature fall @ 45+/- 6.5°F
	Summer	Open on temperature rise @ 75+/- 6.5°F
Power Consumption: 150 Watts @ +/- 10% at 14 VDC		
<p>Diesel Fuel Specification Type and Sulfur Content % (ppm) used, must be compliant with all applicable emission regulations for the area in which the engine is operated.</p> <p>Since KUBOTA diesel engines of less than 56 kW (75 hp) utilize EPA Tier 4 and Interim Tier 4 standards, the use of ultra low sulfur fuel is mandatory for these engines, when operated in US EPA regulated areas. Therefore, please use No.2-D S15 diesel fuel. Ultra Low Sulfur Diesel (ULSD) 15 ppm or 0.0015 wt.%</p>		
Intake Heater:	Amperage - 42 amps at 12 VDC	
	Resistance (cold) - Approx. 0.3 ohms	
Horsepower:	24.8 HP @ 1800 RPM at sea level. (SAE J1995 Gross Power Rating)	

Cooling System:	Capacity	6 U.S. quarts (5.68 liters) - includes 1 quart (0.95 liter) in coolant recovery bottle. (Refer to section 4.4.5)
	Anti-Freeze: Extended Life	The cooling system is factory charged with a 50/50 mix of extended life coolant (ELC) and deionized water. This mixture provides protection to -34°F (-37°C). For replacement, use Shell Rotella ELC Nitrite Free Pre-Diluted 50/50 antifreeze / coolant.
	Water Temperature Safety Switch Setting:	
	Opens	230 +/- 5°F (110 +/- 3°C)
	Resets	200°F (93°C) - minimum
	Thermostat:	
	Starts to open	177 to 182°F (80 to 84°C)
	Fully open	203°F (95°C)
	Low Coolant Sensor:	
	Opens	Los of 32 ounces of coolant or more
	Closes	Refilling of radiator to proper level
Lubrication System:	Oil Pressure	35 to 60 psig (3.3 to 5.2 kg/cm)
Electrical:	Generator	400-500 VAC @ 60 hz 360-460 VAC @ 50 hz

SECTION 3

OPERATION

3.1 Generator Set Installation

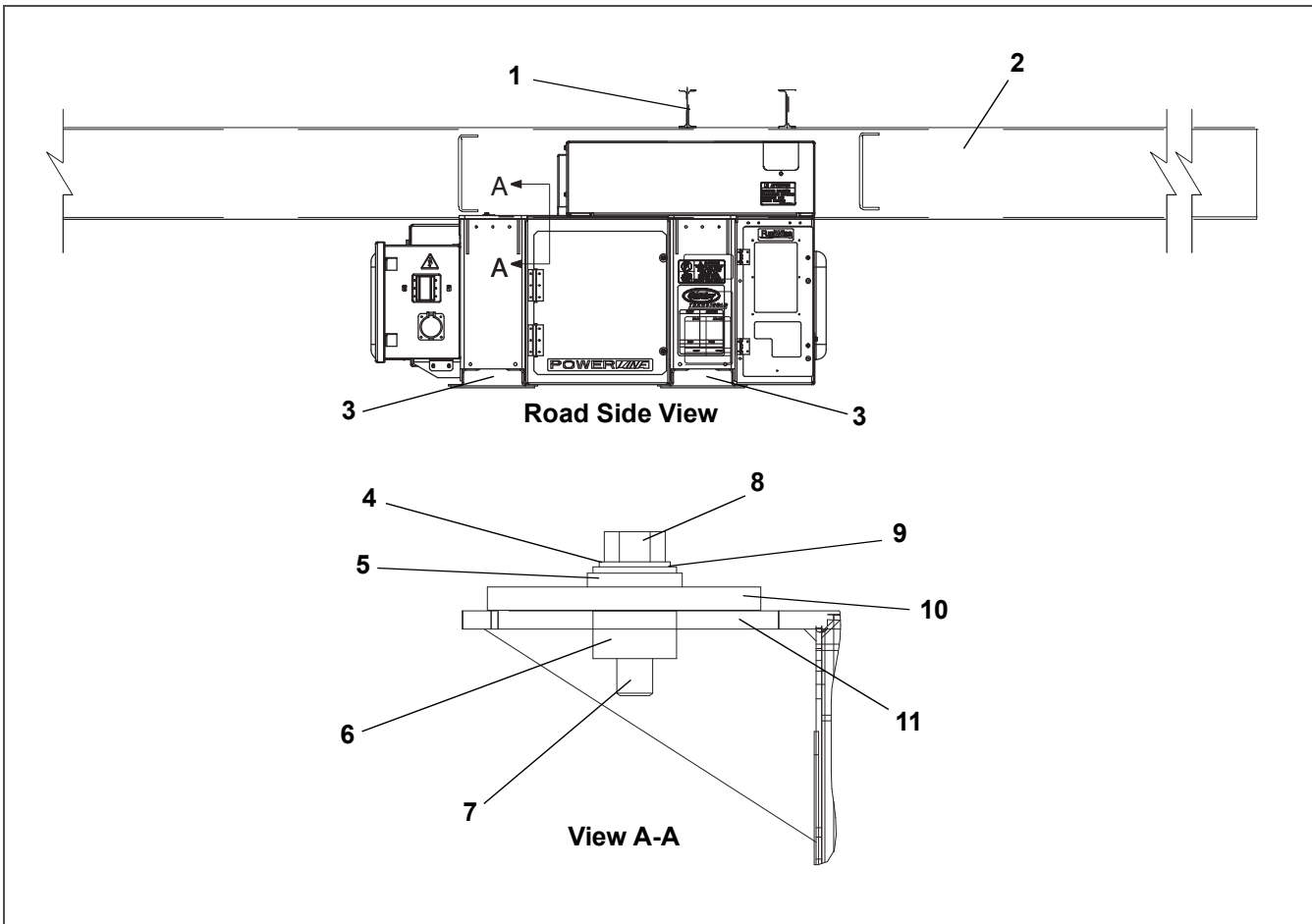
The generator set is mounted under the center of the trailer chassis and is easily handled with a fork lift truck capable of handling 2,000 pounds. The fork lift pockets provided are accessible from either side. Mounting clamps are designed to be attached to outside I-beam flanges only. Maximum chassis width is 38 inches on center.

1. Instructions for Standard Mount:
 - a. Loosen the mounting bolts (see [Figure 3.1](#)) enough to push the mounting plates to the outermost position.
 - b. Place forks into the fork lift pockets of the generator set. Attach the safety chain between the unit and fork truck.
 - c. Center the generator under the chassis slide mounting plates fully onto the chassis I-beams and torque mounting bolts to 80 - 90 ft-lbs (11.1 - 12.4 m-kg). Upon completion, remove the safety chain before removing forks of fork lift truck from the unit.
2. Instructions for Quick Mount:
 - a. Loosen the mounting bolts (see [Figure 3.2](#)) enough to bring the clamp to open position. To orient in open position, lift the nut end of the bolt out of slot. The clamp will fall open.
 - b. Place forks into the fork lift pockets of the generator set. Attach the safety chain between the unit and fork truck.
 - c. Center the generator set in desired position under the chassis.
 - d. Lift the clamp in place, ensuring the bolt is secured in the slot.
 - e. Tighten the bolt to 55 - 65 ft-lbs (7.6 - 9.0 m-kg).
 - f. Upon completion, remove the safety chain before removing forks of the fork lift truck from the unit.

3.2 Generator Set Removal

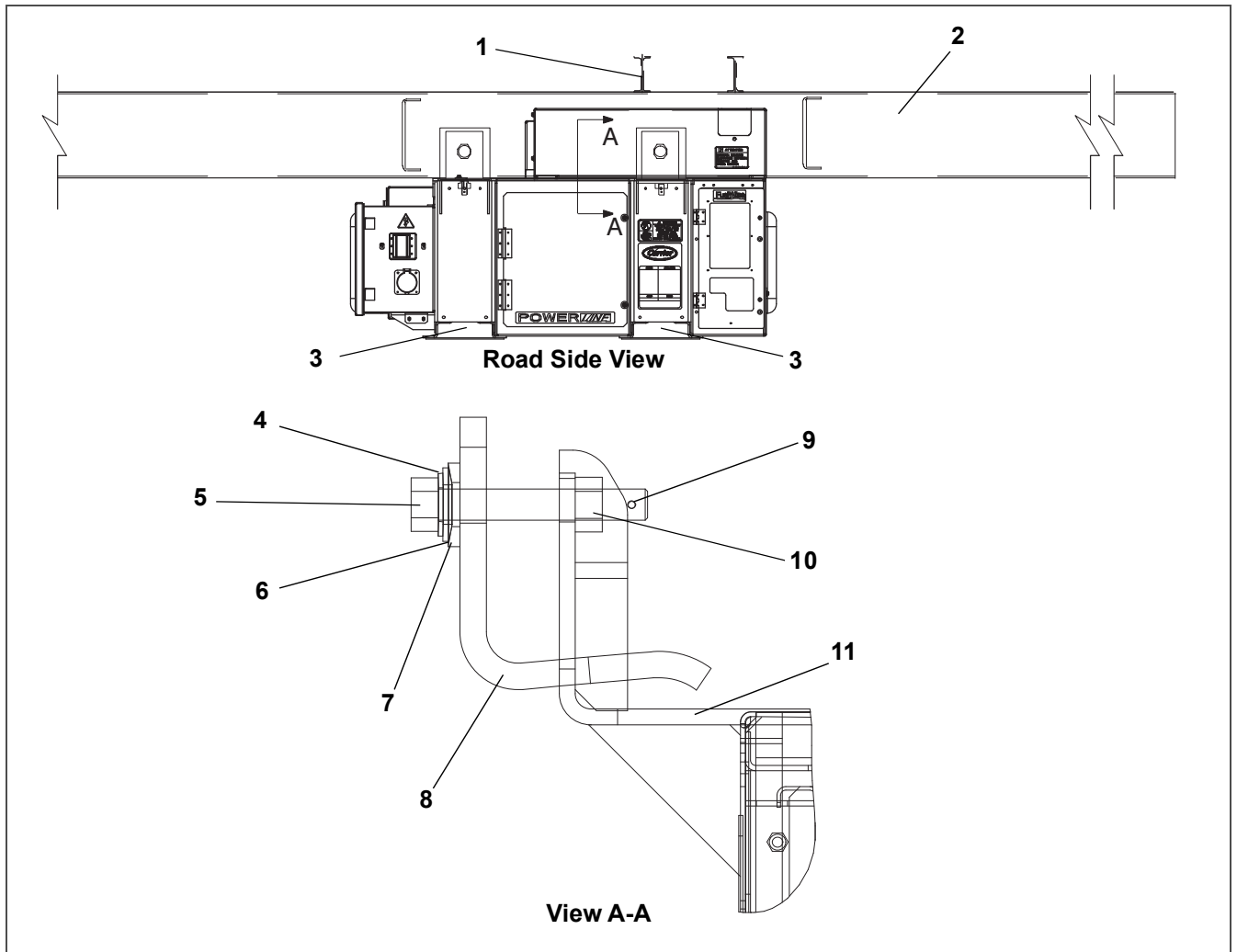
1. Instructions for Standard Mount:
 - a. Disconnect power cable to generator (if connected).
 - b. With fork lift in position and safety chain attached, slide mounting plates back sufficiently to clear chassis.
 - c. Lower and remove generator.
2. Instructions for Quick Mount:
 - a. Disconnect power cable to unit (if connected).
 - b. With fork lift in position and safety chain attached, loosen mounting bolts, and lift end of bolts out of slot to orient clamps to open position.
 - c. Lower and remove generator.

Figure 3.1 Generator Set Mounting - Standard Mount



- | | |
|---------------------------------|----------------------------|
| 1) Container Floor Cross I-Beam | 7) Roll Pin |
| 2) Rear of Chassis | 8) Bolt |
| 3) Fork Lift Pocket | 9) Washer, Spherical, Male |
| 4) Washer, Belleville | 10) Mounting Plate |
| 5) Washer, Spherical, Female | 11) Generator Frame |
| 6) Tee Nut | |

Figure 3.2 Generator Set Mounting - Quick Mount



- | | |
|---------------------------------|------------------------------|
| 1) Container Floor Cross I-Beam | 7) Washer, Spherical, Female |
| 2) Rear of Chassis | 8) Angle Assembly, Clamp |
| 3) Fork Lift Pocket | 9) Roll Pin |
| 4) Washer, Spherical Belleville | 10) Nut, Hex, 3/4-10 |
| 5) Bolt | 11) Frame Assembly |
| 6) Washer, Spherical, Male | |

3.3 Starting and Stopping Instructions

3.3.1 Pre-Start Inspection

1. Check engine lubrication and fuel filters, oil lines, and connections for leaks. If required, tighten connections and / or replace gaskets.
2. Check engine lubricating oil level (see [Section 2.10](#)).
3. Check the poly V-belt for fraying or cracks and proper tension (see [Section 5.4.11](#)).
4. Check the radiator hoses for leaks and check radiator coolant level (see [Section 2.10](#)).
5. Check the radiator coil and generator air intake screen for cleanliness. If required, clean using compressed air, reversing the normal air flow.
6. Check the air cleaner for cleanliness and clean if necessary (see [Section 5.4.12](#)).
7. Check the in-line fuel strainer and clean if necessary (see [Section 5.4.4](#)).
8. Drain water from the fuel tank sump and filter bowl.
9. Fill the fuel tank with diesel fuel (see [Section 2.10](#)).
10. Check the air intake heater amperage (see [Section 2.10](#)).
11. Check battery terminals for cleanliness and secureness. If required, clean, then coat with a battery terminal sealant.
12. Check, and if required, tighten all electrical connections.
13. Check, and if required, tighten all hardware (brackets, etc.).
14. Ensure the main generator set Circuit Breaker (CB1) is in the OFF position. Connect power cable to refrigeration unit and proceed to Starting Instructions (see [Section 3.3.2](#)).

3.3.2 Starting Instructions

Before start up, both the Genset Circuit Breaker (CB1) and the refrigerated unit should be OFF. After start up, the Genset unit should be run for at least two minutes to allow the power source to stabilize before supplying power to the refrigerated unit. This will eliminate the potential of any cold start transient spikes from reaching the refrigerated unit. Cold start transient spikes can potentially cause nuisance over voltage alarms on refrigerated units that are sensitive to electrical spikes or transients.

WARNING

Beware of moving poly V-belt, belt driven components and hot exhaust components.

WARNING

Under no circumstances should ether or any other unauthorized starting aids be used in conjunction with the air intake heater.

NOTICE

Piston rings in engines that have operated less than 100 hours may not be fully seated. This may lead to the possibility of oil seepage from the exhaust pipe. To properly seat the rings, operate the engine under full load for a period of 24 hours. If the condition persists, check valve clearance when the engine is cold. (Refer to engine workshop manual listed in [Section 2.2](#)).

1. Instructions for Standard Units:
 - a. Make sure that Circuit Breaker CB-1 is in the OFF position.
 - b. Hook up the 460 volt cable from the refrigerated unit to the Genset receptacle.
 - c. Hold the Intake Heater Switch (HS) in the PREHEAT position (see [Figure 2.11](#)). Suggested hold times for a cold engine are as follows:

Cold Engine Preheat Times	
Ambient Temperature	Time
26°C (78°F)	5 seconds
0° to 26°C (32°F to 78°F)	10 seconds
-8° to 26°C (18°F to 32°F)	20 seconds
Below -8°C (18°F)	30 seconds

- d. With the Intake Heater Switch (HS) held in the PREHEAT position, place the Ignition Switch (IGN) in the START position.
 - e. After the engine has started, continue to hold the Intake Heater Switch (HS) in the PREHEAT position until the engine develops sufficient oil pressure to close the Oil Pressure Safety Switch (approximately 5 seconds). When released, the Intake Heater Switch (HS) will automatically return to the OFF position and the heater will remain energized for 3 minutes.
2. Instructions for Units with Auto Start:
- a. Make sure that Circuit Breaker CB-1 is in the OFF position.
 - b. Hook up the 460 volt cable from the refrigerated unit to the Genset receptacle.
 - c. Place the Ignition Switch (IGN) in the RUN position.
 - d. If the Low Coolant Sensor (LCS) is immersed in coolant, the Auto Restart Module will energize the heater for 30 seconds and the safety buzzer will sound. After the 30 second delay, the unit will attempt to start.

3.3.3 Post-Start Inspection

1. Allow the Genset unit to run for at least 2 minutes.
2. Turn on Circuit Breaker CB-1.
3. Check generator output with a volt meter, voltage output at start up with no load at 50Hz operation should be 1500 RPM, 360-460 VAC. Voltage output may vary and fall with ISO specifications based on ambient (see [Section 2.6](#)).
4. Start the refrigeration unit.
5. Run the engine for 10 minutes (check total time meter operation).
6. Listen for abnormal bearing noise (AC generator).
7. Check the fuel lines, lube oil lines, and filters for leaks.
8. Check the exhaust system for leaks.

3.3.4 Stopping Instructions

1. Place Circuit Breaker CB-1 in the OFF position.
2. Place the Ignition Switch (IGN) in the OFF position.

3.4 Sequence of Operation Warning

Beware of moving the poly V-Belt and belt driven components.

1. Standard Units:

With the Intake Heater Switch (HS) held in the ON position, current flows through the ammeter to the Intake Heater (IH). While the heater is on, the ammeter will show a 42-amp draw.

A second set of contacts also energizes the Safety Relay (S).

If the High Water Temperature Switch (HWT) opens to break the safety relay ground connection, the Safety Relay (S) will not energize, and the engine will not start.

To start the engine, the Ignition Switch (IGN) is held in the START position. With the switch in the START position, current flows to the Starter Solenoid (SS), through the SS contacts to the Starter Motor (SM). Current then flows to the Intake Heater Timer (IHT), Intake Heater Relay (HR) and to the heater, while simultaneously powering the Electronic Governor Module (EG), Fuel Solenoid (FS), and Engine Speed Sensor (ESS).

The Starter Motor (SM) turns over the engine resulting in pumping of fuel to the engine cylinders by the injection pump. This fuel is ignited by heat of compression; thus starting the engine. When the engine has developed sufficient oil pressure, the Low Oil Pressure Switch (LOP) contacts close to maintain power to the Safety Relay (S).

Once the engine has started, the Intake Heater (IH) will remain energized for 3 minutes.

The Ignition Switch (IGN) will be released. The Intake Heater Switch (HS) will be held for 5 seconds, then released after the Ignition Switch (IGN) is released. When the START switch is released, the starter will be disengaged.

With the engine running, the battery charger provides DC power to operate the control system and charge the battery.

2. Units with Auto Start, Low Coolant Sensor:

When the Ignition Switch (IGN) is placed in the RUN position, 12-volt DC power is applied to the Low Coolant Sensor (LCS), if applicable, and the Auto Restart Module simultaneously. If the coolant level is below the sensor, all the indicator lights on the Auto Restart Module will blink once and the LCS will open the contacts on the low coolant relay, de-energizing the unit's 12-volt DC circuitry. If the coolant level is above the sensor, the Auto Restart Module will maintain power and all lights on the module will illuminate. As the Auto Restart Module performs its self test, the lights will go out individually.

After the self test is complete, the Auto Restart Module will energize the Intake Heater (IH) and sound the audible alarm warning, indicating that the unit has been powered on and will start. The 30-second delay starts at this time. When the 30-second delay expires, power will be applied to the Electronic Governor (EG) and the engine attempts to crank for 15 seconds.

When the engine starts, the Intake Heater (IH) will remain energized for 3 minutes; during this time, the engine / intake heater light and alarm will be energized, the shutdown/lockout time delay of 15 seconds will begin counting, and the starter will be disengaged. During the shutdown/lockout time delay at start up, the Auto Restart Module will disregard the signals to the oil pressure and engine temperature inputs, and the Run sequence will begin. If engine does not start, refer to [Table 2-2](#) for Auto Restart Sequencing.

SECTION 4 TROUBLESHOOTING

4.1 Diesel Engine

4.1.1 Engine Will Not Start

Table 4–1 Engine Will Not Start

Condition	Possible Cause	Remedy / Reference Section
Starter motor will not crank or low cranking speed	Battery insufficiently charged	Charge
	Battery terminal post or battery defective	Check
	Electrical connections at starter are bad	Correct
	Starter motor malfunctions	Section 4.1.4
	Starter motor solenoid defective	Engine Manual
	Open starting circuit	Section 4.1.5
	Incorrect grade of lubricating oil	Section 2.10
	Fuse F5 is bad	Replace
Starter motor cranks, but fails to start	No fuel in tank	Section 2.9 / Section 2.10.
	Air inside the fuel system	Section 5.4.1
	Water inside the fuel system	Drain Sump
	Plugged fuel filters	Replace
	Air intake heater is bad	Section 5.4.14
	Low oil / oil pressure switch defective	Section 5.4.7
	Faulty heater switch	Section 5.4.15
	Plugged fuel lines to injector(s)	Engine Manual
	Mechanical lift fuel pump malfunction	Engine Manual
	Fuses F1, F2, F3, F4 are bad	Check/ Replace
	Loose or no connection between wire harness and Electronic Governor Module (EG)	Check / Correct
	Starter cranks and engages, but dies after a few seconds	Engine lube oil too heavy
Voltage drop in starter cable(s)		Check

4.1.2 Engine Starts Then Stops

Table 4–2 Engine Starts Then Stops

Condition	Possible Cause	Remedy / Reference Section
Engine stops after a few rotations	No fuel in tank	Section 2.9 / Section 2.10.
	Intake heater switch not held long enough	Hold switch
	Fuel filter restricted	Replace
	Air cleaner or hose restricted	Section 5.4.12
	Engine crankcase breather or hose restricted	Section 5.4.13
	Safety device open	Section 2.8
	Open wiring circuit to fuel solenoid	Check
	Fuel solenoid defective	Replace
	Fuel supply restricted	Section 2.10, Section 5.4.2, and Section 5.4.3
	Mechanical lift fuel pump malfunction	Engine Manual
	Low oil / oil pressure switch defective	Section 5.4.8
	Leak in fuel system	Check
	Injector nozzle(s) defective	Engine Manual
	Injection pump defective	Engine Manual
Generator internal overloads open	Table 2–3	

4.1.3 Engine Will Not Shut Off

Table 4–3 Engine Will Not Shut Off

Condition	Possible Cause	Remedy / Reference Section
Engine will not shut off	Loose ground connection	Clean / Tighten
	Improperly seated fuel solenoid	Correct

4.1.4 Starter Motor Malfunction

Table 4–4 Starter Motor Malfunction

Condition	Possible Cause	Remedy / Reference Section
Starter motor will not crank or turns slowly	Battery insufficiently charged	Charge
	Battery cable connections loose or oxidized	Check / Replace
	Battery cables defective	Check / Replace
	Starter brushes shorted out	Engine Manual
	Starter brushes hang up, defective or have no contact	Engine Manual
	Starter solenoid damaged	Engine Manual
	Ignition switch defective	Replace
	Engine lube oil too heavy	Table 2.10.
Starter motor turns, but pinion does not engage	Pinion or ring gear obstructed or worn	Engine Manual
Starter motor does not disengage after switch has been released	Ignition switch is bad	Check/Replace
	Starter motor solenoid is bad	Engine Manual
Pinion does not disengage after engine is running	Starter is bad	Engine Manual

4.1.5 Malfunction In The Engine Starting Circuit

Table 4–5 Malfunction In The Engine Starting Circuit

Condition	Possible Cause	Remedy / Reference Section
No power to starter motor solenoid	Battery defective	Correct
	Loose electrical connections	Tighten
Fuel solenoid does not energize or does not remain energized	Battery defective	Correct
	Loose electrical connections	Tighten
	Oil pressure switch defective	Section 1.9
	Water temperature safety switch open	Section 1.9
	Fuel solenoid defective	Engine Manual
	Intake heater switch is bad	Check (Engine Manual)
	Electronic Governor Module (EG) is bad	Replace (Section 5.4.15) Check / Replace
Intake heater does not energize	Intake heater switch is bad	Section 5.4.15
	Timer is bad	Section 5.4.15
	Heater element is bad	Section 5.4.15
	Heater relay is bad	Section 5.4.15

4.1.6 Miscellaneous Engine Troubleshooting

Table 4–6 Miscellaneous Engine Troubleshooting

Condition	Possible Cause	Remedy / Reference Section
Loss of power	Restriction in air cleaner	Section 5.4.12
	Air in fuel system	Section 5.4.1
	Air vent restricted	Clean
	Restricted fuel lines	Engine Manual
	Fuel injection pump is bad	Engine Manual
	Injector(s) bad or incorrect type used	Engine Manual
	Incorrect fuel injection pump timing	Engine Manual
	Incorrect valve timing	Engine Manual
	Poor compression	Engine Manual
Vibration	Engine shockmounts are bad	Replace
	Poor compression	Engine Manual
Overheating	Restriction in air cleaner	Section 5.4.12
	Exhaust pipe restriction	Remove
	Restriction in water jacket	Engine Manual
	Restriction in radiator	Section 5.4.5
	Coolant level too low	Section 2.10.
	Loose water pump/alternator poly V-belt	Section 5.4.11
	Thermostat is bad	Engine Manual
	Water pump is bad	Engine Manual
Excessive crankcase pressure	Plugged crankcase breather line	Section 5.4.13

4.2 Battery Charger (Solid State)

Table 4–7 Battery Charger (Solid State)

Condition	Possible Cause	Remedy / Reference Section
CB4 trips when charger is turned on	Short in 12-volt wiring causing overload of charger	Locate and remove short or replace charger
Circuit breaker trips repeatedly, even when not connected	Internal short	Replace charger
Charger does not taper back after charging for a few minutes	Bad cell in battery	Test battery for defect according to battery manufacturer's instructions
	Charger is bad	Replace

Table 4–7 Battery Charger (Solid State)

Condition	Possible Cause	Remedy / Reference Section
Charger does not charge	Open BCF3, BCF4, or BCF5	Replace
	Charger is not receiving AC input	Use voltmeter to confirm charger is receiving 360-500 VAC. If not, check input connections/fuses.
	Charger output is not connected to 12 volt battery	Check output wiring connections to battery.
	Charger is bad	Replace
Low output voltage measured across charger output	Battery not connected to charger. It is normal to measure 12 volts or less across charger output with no battery connected	Check charging leads from charger to battery
Reverse polarity connection to battery has caused charger to stop charging	Internal DC fuse blown and possible damage to current carrying components	Replace

4.3 Alternating Current Generator

Table 4–8 Alternating Current Generator

Condition	Possible Cause	Remedy / Reference Section
No voltage	Loss of rotor magnetism	Replace
	Circuit breaker tripped	Check CB1
	Open in stator windings	Replace
	Short circuited	Replace
	Worn drive gear stripped	Check/Replace
	Contactors not engaged	Replace
Low voltage	Low engine speed	Section 5.4.9
	High resistance connections - connections are warm or hot	Tighten
	Loss of rotor magnetism	Replace
Fluctuating voltage (May be indicated by flickering lights)	Fluctuating speed	Section 5.4.9
	Irregular speed of engine	Engine Manual
	Loose terminal or load connections	Tighten
	Bad bearing causing uneven air gap	Replace
High voltage	Excessive engine speed	Section 5.4.9

Table 4–8 Alternating Current Generator

Condition	Possible Cause	Remedy / Reference Section
Overheating	Generator overloaded	Check
	Clogged vents/baffles	Check / Clean
	High temperature surrounding generator	Section 5.4.5
	Insufficient air circulation or recirculation	Check / Clean
	Unbalanced load	Balance
	Dry bearing	Replace
Mechanical Noise	Bad bearing	Replace
	Rotor rubbing on stator	Replace
	Loose laminations	Replace
	Loose or misaligned coupling	Check drive gear
Generator frame produces shock when touched	Static charge	Check ground to frame
	Grounded armature of field coil	Replace

4.4 Auto Re-Start Option

Table 4–9 Auto Re-Start Option

Condition	Possible Cause	Remedy / Reference Section
When the Ignition switch is placed in the RUN position, nothing happens- no lights illuminate	Wait 30 seconds for intake heater to be activated	Wait
	Coolant level below the low coolant sensor	1.10.j
	Relay defective	Check / Replace
	Ignition switch defective	Check / Replace Switch
	3 amp Fuse is bad	Check and Replace Fuse
	Loose connector on module	Tighten connector
	Auto restart module is bad	Check for 12 volts at Pin 4 / Replace module
Alarm sounds, but engine does not crank	Mis-wired connectors	Check / Correct wiring
	No voltage at Pin 2 of the connector	Trace / Correct
	Check Starter Solenoid	Section 4.1.1
Engine starts, but the starter does not disengage	Auto restart module is bad	Replace module
	Speed Sensor wiring loose	Check/Correct
	Speed Sensor is bad	Replace
Engine starts, but shuts down from over speed	Auto restart module is bad	Replace module
	Electronic Governor Module (EG) is bad	Replace

Table 4–9 Auto Re-Start Option

Condition	Possible Cause	Remedy / Reference Section
Engine cranks, but will not start	Electronic Governor Module (EG) is bad	Replace
	Section 4.1.1	Section 4.1.1
Engine starts, but shuts down on low oil	Section 4.1.2	Section 4.1.2
Engine starts, but shuts down on high water temperature	Section 4.1.6	Section 4.1.6

4.5 Electronic Governor Module

Table 4–10 Electronic Governor Modules

Fault	LED flash code	Possible Cause
Engine Over Speed: more than 2,530 RPM	One Long–One Short	ESS or mechanical engine problem
Actuator Wiring Disconnection. No signal from ESS for 2 seconds after RPM is greater than 1,000 RPM for 10 seconds, OR for 5 seconds while engine cranking (no voltage at EG pin 18).	Two Long–One Short	Short ESS or wiring problem
Speed Sensor Disconnection. Fuel/speed actuator (FS) wiring disconnected or open circuit. Coil Resistance Spec: 2.8 ohm +/- 10%.	Two Long–Three Short	FS or wiring problem
EG supply voltage is greater than 26V.	Two Long–Seven Short	EG or alternator problem

4.6 Voltage Controller

The voltage controller has one green indicator light and one yellow indicator light. When the green light is illuminated, it means that the voltage controller is receiving power. During normal operations the yellow light is continuously blinking at a one Hz rate. If there is a problem then the yellow light will blink at various rates depending upon the fault. Refer to the chart below to determine the fault.

Table 4–11 Voltage Controller

Green LED	Fault	Possible Cause / Remedy
LED not illuminated	No power to the voltage controller	Contactors failed
		Check line side power on contactors

Yellow LED flash Code	Fault	Possible Cause / Remedy
One Long–Three Short	Over Voltage Error	Engine speed, check
One Long–Four Short	Under Voltage Error	Engine speed, check

4.7 High Voltage Circuit

Electrical troubleshooting for high voltage control circuit



Before proceeding with the troubleshooting, make sure to follow your company's standard safety procedures for working with electrical components.

Item	Checks	Potential Cause
Receptacle (R)	Check output voltage at Receptacle R (L1-L2, L2-L3, L1-L3) (50Hz: 360 - 460 VAC, and 60Hz: 400 - 500 VAC)	Faulty Receptacle (Replace)
High Voltage Wires (from Circuit Breaker to Receptacle)	Check if wires/terminals are connected (Check Continuity for each leg)	Loose connections (Tighten)
Circuit Breaker (CB)	Test the output power from Circuit Breaker CB (21-22, 22-23, 21-23)	Faulty Circuit Breaker (Replace), Circuit Breaker (CB) is in the OFF position
	Verify Circuit Breaker (CB) is in the ON position	
	Test the input power to the Circuit Breaker CB (11-12, 12-13, 11-13)	
High Voltage Wires (from Primary and Boost Contactors to Circuit Breaker, Voltage Controller, Fuse Blocks, Generator, and Battery Charger)	Check if wires/terminals are connected (Check Continuity for each leg)	Loose connections (Tighten)
Primary (P) or Boost (B) Contactor	Visually verify Primary (P) or Boost (B) Contactor is energized (wait 10-20 seconds after start-up)	Faulty Contactor / Faulty Voltage Controller / Faulty Fuses / Faulty Generator (Replace)
	Test the output voltage from Primary (P) or Boost (B) Contactor (L1-L2, L2-L3, L1-L3) (50Hz: 360 - 460 VAC, and 60Hz: 400 - 500 VAC)	
	Test the input voltage to Primary (P) or Boost (B) Contactor (T1-T2, T2-T3, T1-T3) (300 - 600 VAC)	
	Test Voltage between terminals A1-A2 of Contactors. Engaged contactor (Primary or Boost) shall be supplied with ~24VDC; Dis-engaged 0VDC.	if Not, check 24VDC circuit/Faulty Voltage Controller (Replace) if Not, check 24VDC circuit/Faulty Voltage Controller (Replace)

Item	Checks	Potential Cause
Voltage Controller (VC) and Fuses	Verify VCF6 Fuse is not blown (Check Continuity for each leg across fuse, outside of circuit; inside of circuit if not running)	Blown Fuse (Replace)
	Verify VCF7 Fuse is not blown (Check Continuity for each leg across fuse, outside of circuit; inside of circuit if not running)	Blown Fuse (Replace)
	Verify VCF1 Fuse is not blown (Check Continuity for each leg across fuse, outside of circuit; inside of circuit if not running)	Blown Fuse (Replace)
	Verify VCF2 Fuse is not blown (Check Continuity for each leg across fuse, outside of circuit; inside of circuit if not running)	Blown Fuse (Replace)
	Verify Voltage Controller has power (powered by high voltage) - verify green light is illuminated	Faulty Voltage Controller, Blown VCF6 or VCF7 Fuse, Loose connections, Faulty Generator (Replace and tighten)
	Verify Voltage Controller has green light illuminated and yellow light flashing at 1 Hz (Yellow light flashing sequence other than at 1 Hz indicates a fault condition)	One Long–Two Short = Voltage Controller Fault (Failed voltage controller, replace)
		One Long–Three Short = Over Voltage Error (Engine speed, check)
		One Long–Four Short = Under Voltage Error (Engine speed, check)
		One Long–Five Short = Hot Start Error (Reset power to the unit)
		One Long–Six Short = Voltage Controller Fault (Failed voltage controller, replace)
		One Long–Seven Short = Voltage Controller Fault (Failed voltage controller, replace)
	Verify that the Connectors to the Voltage Controller are secured (Snapped in place and do not easily pull out)	Check if the connectors are pushed in all the way
		Remove connectors and inspect terminal pin insertion depth (all the same)
Check to see if wires/terminals are connected (Check)		

Item	Checks	Potential Cause
Primary (P) or Boost (B) Contactor	Visually verify Primary (P) or Boost (B) Contactor is energized (wait 10-20 seconds after start-up)	Faulty Contactor / Faulty Voltage, Controller / Faulty, Fuses / Faulty Generator (Replace)
	Test the output voltage from Primary (P) or Boost (B) Contactor (L1-L2, L2-L3, L1-L3) (50Hz: 360 - 460 VAC, and 60Hz: 400 - 500 VAC)	
	Test the input voltage to Primary (P) or Boost (B) Contactor (T1-T2, T2-T3, T1-T3) (300 - 600 VAC)	
	Test Voltage between terminals A1-A2 of Contactors. Engaged contactor (Primary or Boost) shall be supplied with ~24VDC; Dis-engaged 0VDC.	if Not, check 24VDC circuit/Faulty Voltage Controller (Replace)

SECTION 5

SERVICE AND PREVENTATIVE MAINTENANCE

5.1 Introduction

This section covers service for the generator set and general engine service. Refer to the Kubota engine workshop manual, Section 1.1, for additional engine servicing.



Beware of moving V-belt and belt driven components.

5.2 Preventative Maintenance Schedule

A tabular listing of the recommended preventative maintenance activities and schedule is provided in [Table 5-1](#).

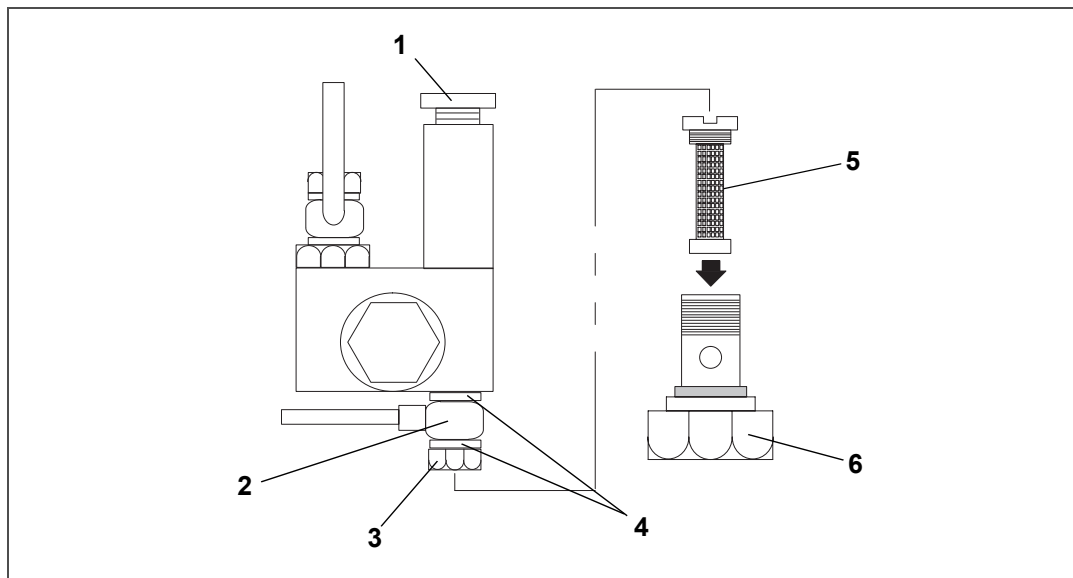
5.3 Battery Service

When replacing the battery, determine whether the unit was supplied with a mat in the battery tray. If so equipped, the mat must also be replaced.

5.4 Engine Service and Components

The unit is equipped with a mechanical fuel pump (see [Figure 5.1](#)) mounted on the engine next to the injection pump.

Figure 5.1 Mechanical Fuel Pump



- 1) Manual Priming Pump
- 2) Banjo
- 3) Nut

- 4) Copper Rings
- 5) Filter
- 6) Nut

5.4.1 Bleeding the Fuel System

The fuel system is a closed circuit which will require bleeding if loss of fuel has occurred. To fill and bleed the system, do the following:

1. Turn the fuel bleed valve (red, see [Figure 2.9](#)) counterclockwise until fully opened.
2. Turn the top of the manual priming pump counter-clockwise to unlock it, and then hand pump the manual plunger until a positive pressure (resistance) is felt. This will indicate fuel flow.
3. Depress and turn the top of the manual priming pump clockwise to lock in place.
4. Start the engine (see [Section 2.3](#)).
5. When the engine is running properly, turn the fuel bleed valve clockwise until fully closed.

5.4.2 Servicing Fuel Pump Internal Filter

The internal fuel filter may become plugged or restricted with foreign particles or wax, which can develop if the wrong grade of fuel is used or untreated fuel is used in cold weather, contaminating the fuel. If the internal filter is plugged, the engine will lose power. Therefore, the filter must be cleaned on a regular basis. The quality of the fuel will affect the filter cleaning schedule (see [Section 5.2](#)).

1. Turn the nut counter-clockwise to loosen and remove.
2. Remove the banjo fitting and let it hang loose.
3. Turn the filter counter-clockwise and remove. Check and clean.
4. To install, reverse steps 1 through 3.

5.4.3 Fuel Filter

The fuel filter is located on the generator set frame (see [Figure 2.9](#)).

1. To replace the fuel filter, loosen and remove the filter housing.
2. Lightly oil new gasket with lube oil.
3. Replace the filter.

NOTICE

If the generator set is equipped with the fuel filter bowl assembly, when replacing the fuel filter, a new fuel filter O-ring should be oiled and replaced, and then the clear bowl should also be tightened to 18 ft-lbs.

5.4.4 In-Line Fuel Strainer

1. Loosen bowl by turning counter-clockwise.
2. To renew, remove in-line fuel strainer. Check and clean, and replace.

5.4.5 Cooling System

To ensure adequate cooling, the radiator must be clean, externally and internally. To service the cooling system, do the following:

1. Remove all foreign material from the radiator coil by reversing the normal air flow. Compressed air or water may be used as a cleaning agent. It may be necessary to use warm water mixed with any good commercial dishwasher detergent. If a detergent is used, rinse coil(s) with fresh water.
2. Drain coolant completely by opening the drain cock and removing the radiator cap.

CAUTION

Never pour cold water into a hot engine.

3. Close the drain cock and fill the system with clean, untreated water to which between 3% and 5% of an alkaline base radiator cleaner should be added; six ounces (dry) = 151 grams to one gallon (3.8 liter) of water.
4. Run the engine 6 to 12 hours and drain the system while warm. Rinse the system three times after it has cooled down. Refill the system with water.

CAUTION

Use only ethylene glycol, anti-freeze (with inhibitors) in the system. Use of glycol by itself will damage the cooling system (see [Section 2.10](#)).

5. Run the engine to operating temperature. Drain the system again and fill with treated water / anti-freeze (see above Caution statement).

5.4.6 Lube Oil Filter

The primary oil filter is located near the radiator fan (see [Figure 2.10](#)).

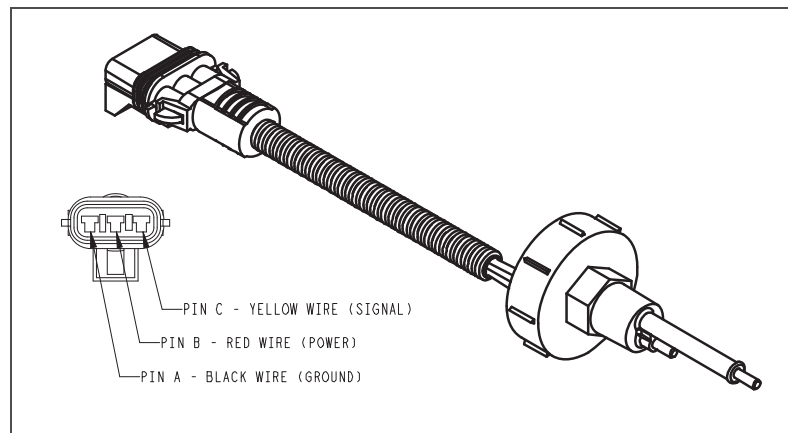
1. After warming up the engine, stop the engine, remove the drain plug from the oil reservoir and drain engine lube oil.
2. Replace filters. Lightly oil the gasket on filter before installing.
3. Add lube oil (see [Section 2.10](#)).
4. Warm up the engine and check for leaks.

5.4.7 Servicing the Low Coolant Sensor

Testing the Low Coolant Sensor (LCS)

1. Verify the coolant level is correct.
2. Verify the wiring to the sensor is correct.
3. Check voltage (12.5 to 13.5 VDC) to the B terminal with the Ignition Switch on (see [Figure 5.2](#)).
4. Check continuity between terminals A and C (see [Figure 5.2](#)) while 12 VDC is applied to terminal B.
5. Drain the coolant from the system to below the level of the coolant sensor and remove the sensor as described in [Section 4.4.7.2](#), below.
6. With the sensor removed from the radiator and 12 VDC applied to terminal B, the circuit between terminals A and C should be open.

Figure 5.2 Low Coolant Sensor



CAUTION

Never open the radiator cap when the coolant is hot.

Replacing the Low Coolant Sensor (LCS)

1. Loosen the radiator drain pet cock and drain coolant to a point below the sensor into an approved container.
2. Unplug the harness and remove the sensor from radiator header.
3. Apply Teflon thread tape or thread sealer to the LCS threads and install the sensor.
4. Reconnect the harness and refill the radiator to proper level.

5.4.8 Servicing Low Oil Pressure Switch

1. Remove the harness connection from the Low Oil Pressure Switch (LOP).
2. Remove the pressure switch from the engine.
3. Apply Teflon thread sealer to the threads of the new LOP switch.
4. Install the new LOP switch.
5. Reconnect harness connection to the low oil pressure switch.

5.4.9 Engine Speed

1. The engine speed is electronically controlled.

NOTICE

Do not attempt to adjust engine speed.

5.4.10 Replacing the Engine Speed Sensor

1. Disconnect the plug to the sensor (see [Figure 2.2](#), [Figure 2.3](#)).
2. Remove the bolt securing the sensor to the housing.
3. Remove the sensor from the housing.
4. Clean the recess in the housing to ensure that the sensor seats properly when re-installed.
5. Re-install the sensor, replace the securing bolt and connect the plug to the sensor.

5.4.11 Servicing Poly V-belt

WARNING

Beware of moving poly V-belt and belt driven components.

WARNING

Beware of pinch points.

NOTICE

A frayed, cracked or worn poly V-belt must be replaced. After installing a new belt, check the adjustment after running the unit for three or four hours. This will allow for the initial stretch, which is common on new belts. Once this initial stretch has taken place, the belt should be checked at regular intervals.

The poly V-belt is driven by a sheave on the engine crankshaft. Its two functions are: (1) to drive the radiator fan and (2) to drive the water pump. To replace the poly V-belt, perform the following steps:

1. Using the proper size socket, slowly rotate the crank on the crank pulley nut. At the same time, use a flat, blunt object to guide the belt off the crank pulley towards radiator. Be careful not to damage grooves on the pulley.
2. Replace the poly V-Belt by positioning the belt on the water pump pulley, and while rotating the engine (as in step 1.), use a flat, blunt object to guide the belt onto the crank pulley. Be careful not to damage grooves on the pulley or belt.

5.4.12 Engine Air Cleaner

The dry element engine air cleaner uses a dry element filter (see [Figure 5.3](#)) to filter the engine intake air. The oil bath air cleaner option uses an oil cup instead of the dry element filter (see [Figure 5.4](#)).

The engine air cleaner should be inspected regularly for leaks (see [Figure 2.2](#), [Figure 2.3](#)). A damaged air cleaner or hose can seriously affect the performance and life of the engine. The air cleaner is designed to effectively remove contaminants from the air stream entering the engine. An excessive accumulation of contaminants in the air cleaner will impair its operation. Therefore, a service schedule must be set up and followed.

1. Check all connections for mechanical tightness. Be sure the air cleaner outlet pipe is not fractured.
2. In case of leakage, if adjustment does not correct the problem, replace necessary parts or gaskets. Swollen or distorted gaskets must always be replaced.

Air Filter Indicator

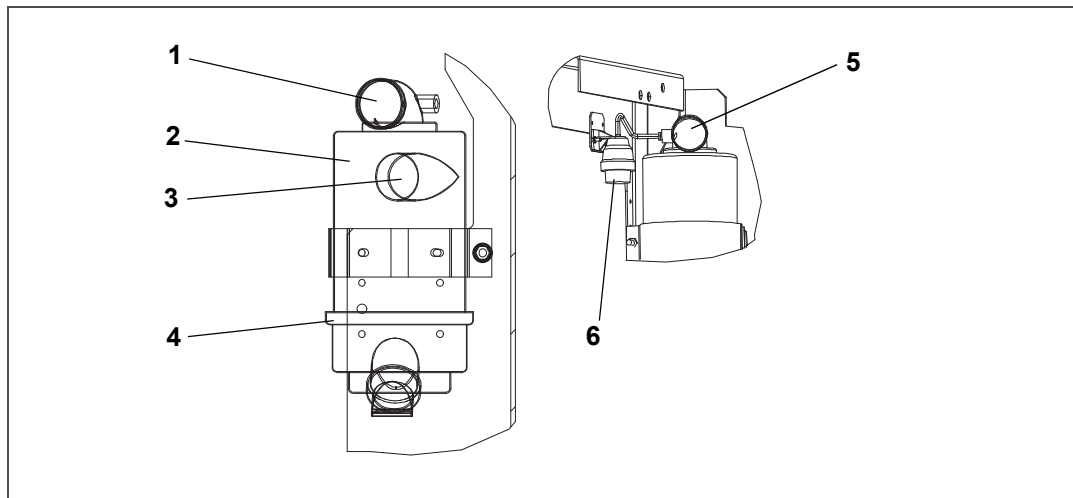
The air filter indicator, used with the dry element filter, is mounted on the unit frame and connected to the engine air intake. Its function is to indicate when the air cleaner dry element needs to be replaced. In operation: When a plugged air cleaner decreases intake manifold pressure to 500 mm (20") WG, the indicator moves to the red line. The air cleaner element should be replaced and the indicator reset by pressing the reset button.

Air Cleaner, Dry Element Service

See [Figure 5.3](#) for this procedure.

1. Stop the engine and open the cap clamps to remove air cleaner bottom cap.
2. Remove the air filter element from the air cleaner body.
3. Install the new element, secure the bottom cap with the cap clamps.

Figure 5.3 Air Cleaner, Dry Element



- | | |
|---------------------|-------------------------|
| 1) Air Outlet | 4) Cap Clamp |
| 2) Air Cleaner Body | 5) Air Outlet |
| 3) Air Inlet | 6) Air Filter Indicator |
-

Air Cleaner, Oil Bath Service

See [Figure 5.4](#) for this procedure.

The oil cup should be inspected during pretrip, before each trip. Never allow more than 1/2 inch (12.7 mm) of dirt deposit in the cup. More than 1/2 inch accumulation could result in oil and dirt carrying over into the engine, causing accelerated engine wear. Heavily contaminated oil will not allow the air cleaner to function properly.



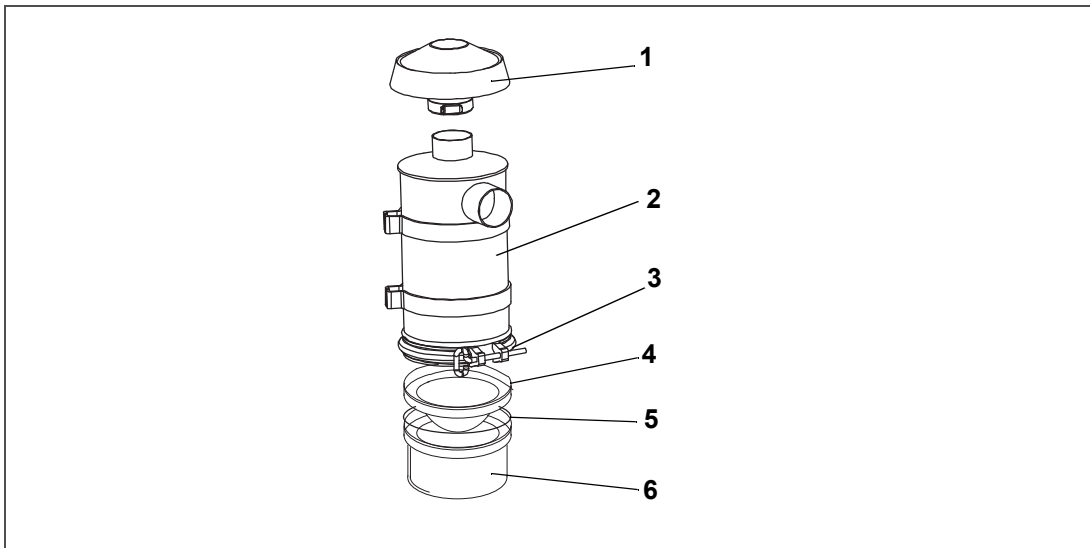
Always cover the engine inlet tube while the air cleaner is being serviced.

1. Stop the engine and remove the oil cup from the air cleaner. Dispose of the oil in an environmentally safe manner.
2. Remove the inner oil cup from the oil cup and clean both cups.
3. Reassemble and fill both oil cups to the indicated level with oil specified in [Section 2.10](#).



Do not underfill or overfill the oil bath cups. Overfilling cups causes loss of capacity; underfilling cups causes lack of filtering efficiency.

Figure 5.4 Air Cleaner, Oil Bath



- 1) Air Inlet Hood
- 2) Air Cleaner Body
- 3) Cap Clamp

- 4) Inner Oil Cup
- 5) Gasket
- 6) Oil Cup

Air Cleaner Body Service

The air cleaner body should be inspected each time the oil cup is serviced. If there is any sign of contaminant buildup or plugging, the air cleaner body should be removed and back flushed.

At least once a year, or at regular engine service intervals, remove the entire air cleaner and perform the following cleaning procedure:

1. Remove oil cup. Check and clean center tube.



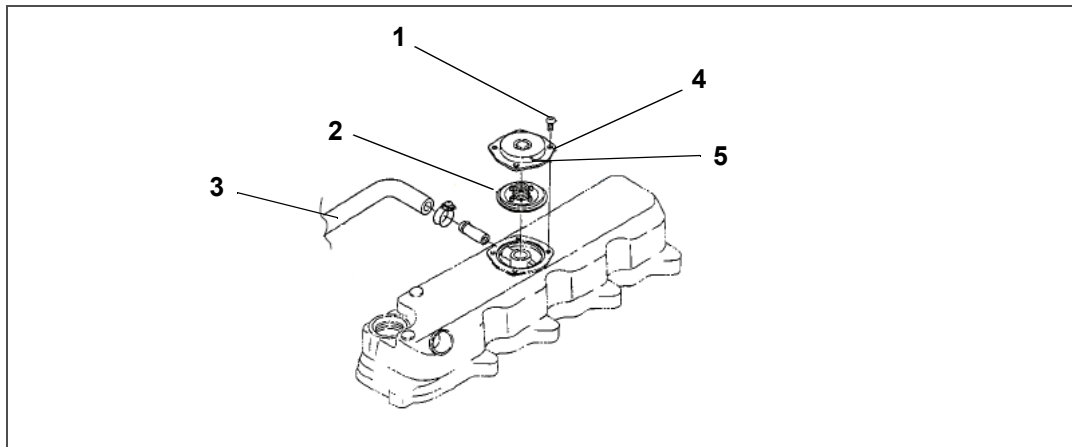
Do not use gasoline to clean air cleaner parts.

2. Pump solvent through the air outlet with sufficient force and volume to produce a hard, even stream out of the bottom of the body assembly. Reverse flush until all foreign material is removed.

5.4.13 Engine Crankcase Breather

The engine uses a closed type breather (see [Figure 5.5](#)) with the breather line attached to the cylinder head cover. It is not necessary to disassemble valve style elements for cleaning. However, the bleed hole should be checked to ensure it is free of obstruction. Check once a year or at every 4,000 hours maintenance interval, whichever comes first.

Figure 5.5 Engine Crankcase Breather

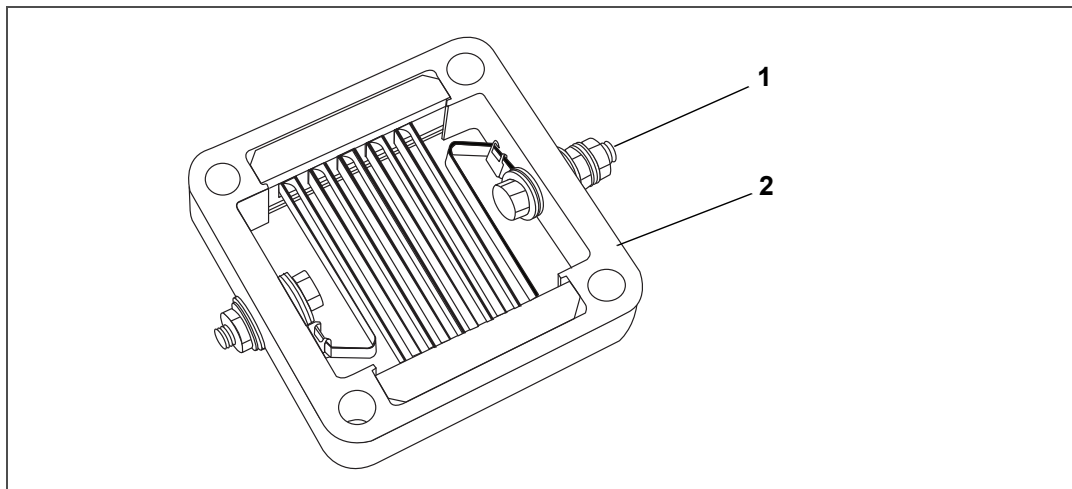


- | | |
|-------------------|-------------------|
| 1) Screw | 4) Breather Cover |
| 2) Breather Valve | 5) Bleed Hole |
| 3) Breather Tube | |

5.4.14 Intake Heater Test

1. Disconnect the lead from the heater terminal.
2. Measure the resistance between the heater positive terminal and the heater body.
3. If the resistance is infinity or significantly different than the specification, resistance (cold) 0.3 ohms, replace the heater.

Figure 5.6 Intake Heater



- | | |
|----------------------|----------------|
| 1) Positive Terminal | 2) Heater Body |
|----------------------|----------------|

5.4.15 Intake Heater Service

1. Remove the harness connection from the heater.
2. Remove the intake transition mounting hardware.
3. Remove the intake transition, heater and both gaskets.
4. Clean the old gasket material off the transition and manifold mounting services.
5. Install the new heater with a new gasket on either side.
6. Assemble transition to heater and torque mounting hardware (refer to engine manual for torque values).
7. Reconnect the harness to heater connection point.
8. Coat the stud on the heater with protective coating.

5.4.16 Intake Heater Switch (HS)

1. Remove the control box cover.
2. Remove all connections going to the Heater Switch (HS).
3. Remove the Heater Switch (HS) from the control box.
4. Install the new Heater Switch (HS).
5. Reconnect the wire harness connections to the switch.
6. Confirm wires are connected to the correct terminals.
7. Reinstall the control box cover.

5.5 Servicing the AC Generator

5.5.1 Remove and Replace Procedure

The only serviceable parts on the Generator are the Drive Gear (metal), Key, Fan, and Fan Cover. If there is a problem with the Generator, it should be replaced using the following procedure:

NOTICE

For additional torque values refer to [Section 5.7](#).

1. Remove the unit top and side panels in order to access the generator.
2. Disconnect the battery.

CAUTION

Observe proper polarity when installing the battery or connecting a battery charger, the negative battery terminal must be grounded. Reverse polarity may damage the charging system. When charging the battery in unit, isolate the battery by disconnecting the negative battery terminal first, then the positive. Once the battery has been charged, connect the positive battery terminal first, then the negative.

3. Remove the truss assembly center nuts and nut plate.
4. Remove the truss side bolts / washers and spacers (2), and remove the truss.
5. Remove the 3/8" bolt / washer that secures the wire harnesses and fuel lines to the top of the generator, move the wire harnesses and fuel lines out of the way.
6. Remove the 1/4" bolts / washers (4) that secure the battery charger bracket to the unit frame. This will allow you to access the cables on the bottom of the battery charger.
7. Mark and disconnect the cables on the battery charger, remove the battery charger assembly from the unit.
8. Remove the bolts / washers (6) that secure the receptacle box to the unit. Wire-tie the receptacle box to the side of the unit so that the receptacle box is not hanging by the cables.
9. Un-tape the wire harness and cut the wires (7) that connect the receptacle box to the generator. Make sure to cut the wires on the receptacle box side of the current butt splices.
10. Remove the bolts / washers (2) that secure the generator support plate to the two generator shockmounts.
11. Remove the bolts / washers (3) that secure the lower radiator access panel (on the other side of the unit) in order to access the engine shockmounts.
12. Back off (about 1"), but do not remove the engine shockmount bolts. This will allow the engine/generator to be slightly lifted off of the unit frame.

NOTICE

The generator / engine must be slightly lifted off of the unit frame in order to provide enough clearance for the generator support plate to slide away from the unit frame.

- Using the lifting lugs on the top of the generator, lift the generator / engine several inches so that the generator support plate will clear the unit frame allowing the entire generator assembly to be removed.
- Place several support beams under the engine, and then lower the generator / engine onto the beams. Make sure that the generator support plate is lifted high enough to allow for the removal of the generator assembly, but not so high that the fan hits the radiator coil.
- Starting with the lower bolts, remove the bolts/washers (12) that secure the generator to the engine.

NOTICE

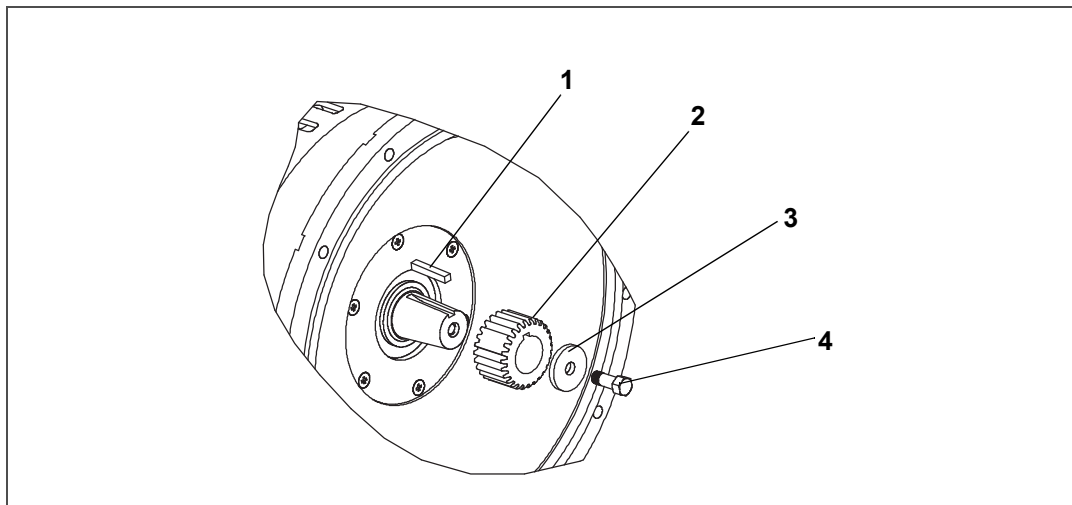
Although the generator drive gear and fly wheel adapter plate will normally keep the generator coupled to the engine, even without the bolts, it is safest to remove the lower generator bolts first, in case the generator shifts and falls during bolt removal.

- Lift the generator assembly (generator & support plate) off of the unit frame and lower it onto a stable work surface.

NOTICE

Inspect the generator drive gear, bolt, and key as they will have to be removed from the old generator and installed onto the new generator; replace these components if they are worn or damaged.

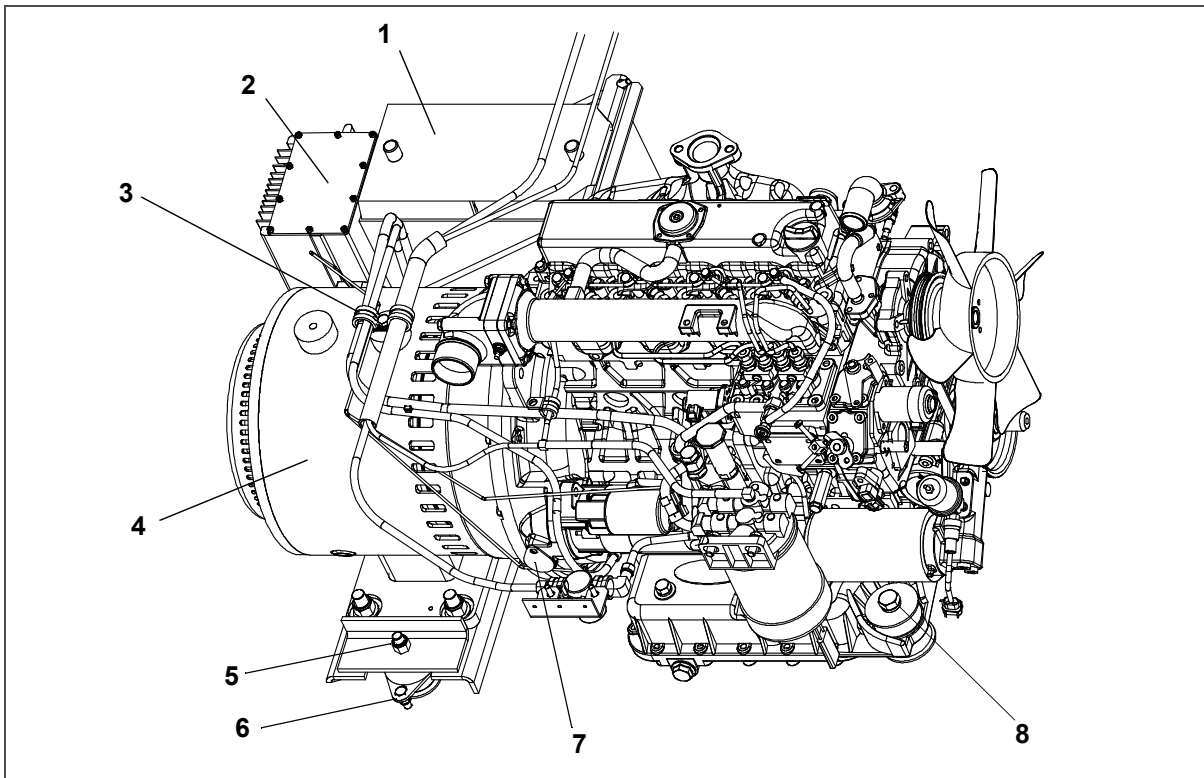
Figure 5.7 Drive Gear



- | | |
|---------------|-----------|
| 1) Key | 3) Washer |
| 2) Drive Gear | 4) Bolt |

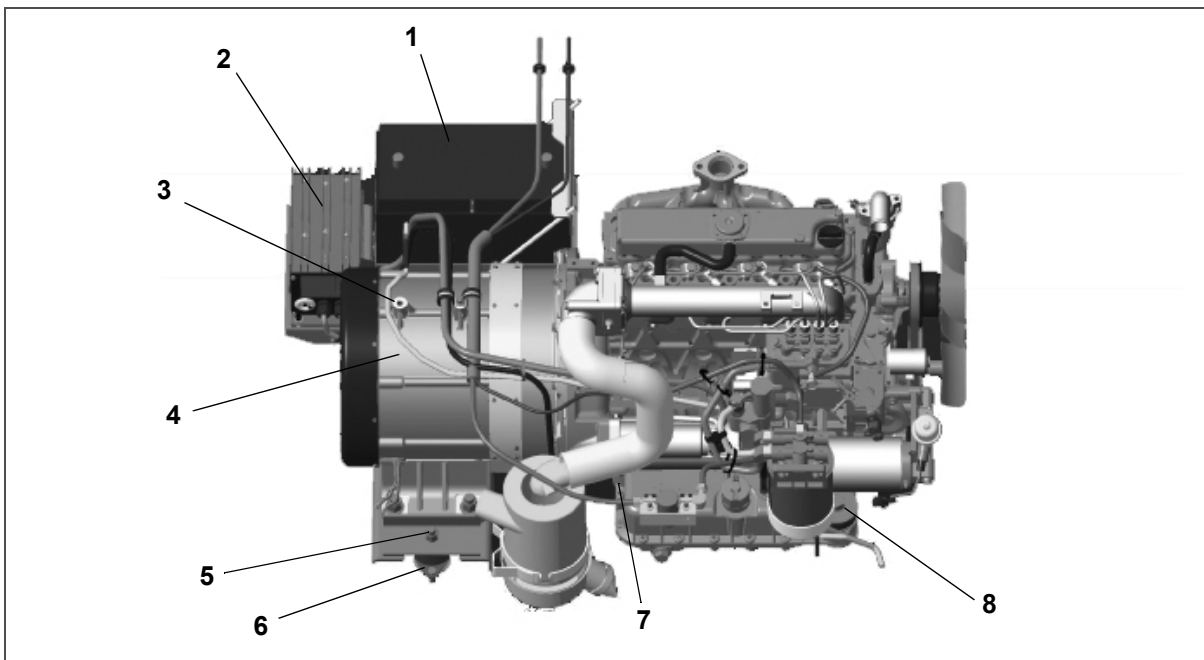
- Remove the generator drive gear bolt / washer.
- Use a gear puller to remove the drive gear and key from the generator drive shaft.
- Place the key into the slot on the drive shaft of the new generator, and install the drive gear over the drive shaft and key.

Figure 5.8 Generator R/R (PIDs prior to UG2019)



- | | |
|----------------------|--|
| 1) Battery | 5) Generator Support Plate Monitoring Bolt |
| 2) Battery Charger | 6) Generator Shockmount |
| 3) Wire Harness Bolt | 7) Fly Wheel Inspection Port |
| 4) Generator | 8) Engine Shockmount Bolt |
-

Figure 5.9 Generator R/R (PIDs UG2019 and Up)



- | | |
|----------------------|--|
| 1) Battery | 5) Generator Support Plate Monitoring Bolt |
| 2) Battery Charger | 6) Generator Shockmount |
| 3) Wire Harness Bolt | 7) Fly Wheel Inspection Port |
| 4) Generator | 8) Engine Shockmount Bolt |
-

20. Replace and torque the generator drive gear bolt / washer, torque to 28 +/-2 ft-lbs. In order to torque generator drive gear bolt you will have to use a strap wrench or similar device to secure the gear while you torque the bolt.
21. Remove the generator support plate from the old generator, and install it onto the new generator.
22. With the drive gear and support plate installed on the new generator, lift and position the generator so that the generator mounting holes (12) are lined up with the engine mounting holes.
23. Insert two generator alignment bolts (2 1/2") to temporarily align/secure the generator to the engine. Tighten the bolts enough so that the metal gear on the generator is touching the blue drive gear on the engine. Do not over tighten the alignment bolts, as they will bottom out on the engine bell housing.

NOTICE

In order to match up the teeth of the generator drive gear with the teeth of the fly wheel adapter plate, the fly wheel will need to be rotated by hand.

24. Open the front access door to access the fly wheel inspection port.
25. Remove the cover of the fly wheel inspection port. Using a long flat-head screwdriver inserted into the fly wheel inspection port, you will be able to slowly rotate the teeth of the fly wheel.
26. With the generator drive gear pressed against the coupling on the fly wheel adaptor plate, use the screwdriver to slowly rotate the fly wheel. Use a flashlight to observe the generator drive gear as you rotate the fly wheel. Once the generator drive gear starts to rotate with the fly wheel, it indicates that the teeth of the generator drive gear have matched up with the mating gear of the fly wheel adaptor plate.
27. Once the teeth of the generator drive gear teeth have lined up with the fly wheel teeth, push the generator in to fully seat the drive gear into the mating gear on the fly wheel adaptor plate.
28. Close and secure the fly wheel inspection port.
29. With the generator drive gear seated into the fly wheel adaptor plate, the alignment bolts (2) can be removed, and the generator mounting bolts (12) can be reinstalled, torque to 25 ft-lbs. Install several mounting bolts to secure the generator before removing the alignment bolts.

NOTICE

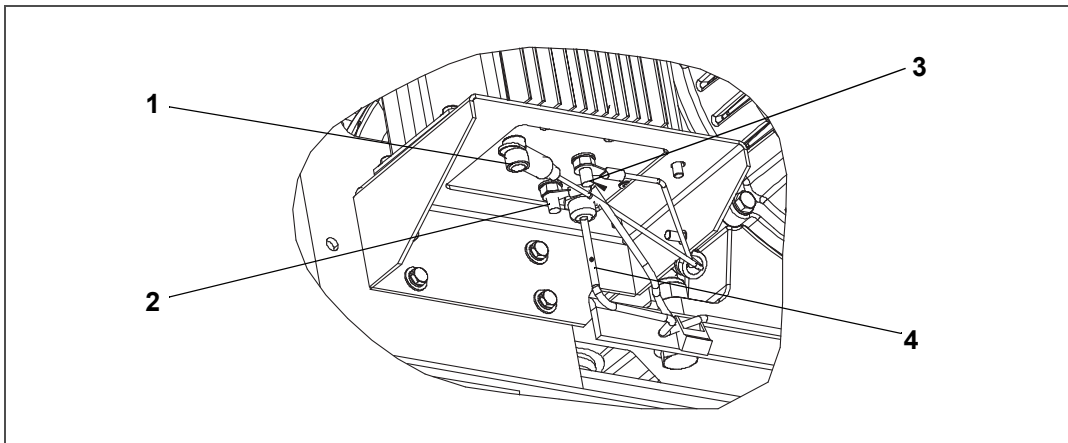
Although the drive gear and mating surface of the generator will generally keep the generator coupled to the engine, even with all of the bolts removed, it is safest to start installation of the top generator bolts first, just in case the generator shifts.

30. With all of the generator mounting bolts secured, use the lift to raise the generator / engine in order to remove the support blocks under the engine.
31. Place the two generator support plate mounting bolts down into the generator support plate in order to line up the mounting bolt holes with the shockmounts.
32. Ensure that the large washers placed on the shockmounts and slowly lower the generator / engine so that the generator support plate holes line up with the shockmount holes.
33. Remove the generator support plate bolts (used for alignment), and install the bolts and large washers from the bottom of the shockmounts through the generator support plate. Secure the bolts (2) with nuts, torque to 75 ft-lbs.
34. Tighten the engine shockmount bolts, torque to 90 ft-lbs.
35. Replace the lower radiator access panel and secure with bolts / washers (3).
36. Re-secure the battery charger cables to the battery charger. See [Figure 5.10](#), [Figure 5.11](#).

CAUTION

Observe proper polarity when installing the battery or connecting a battery charger, the negative battery terminal must be grounded. Reverse polarity may damage the charging system. When charging the battery in unit, isolate the battery by disconnecting the negative battery terminal first, then the positive. Once the battery has been charged, connect the positive battery terminal first, then the negative.

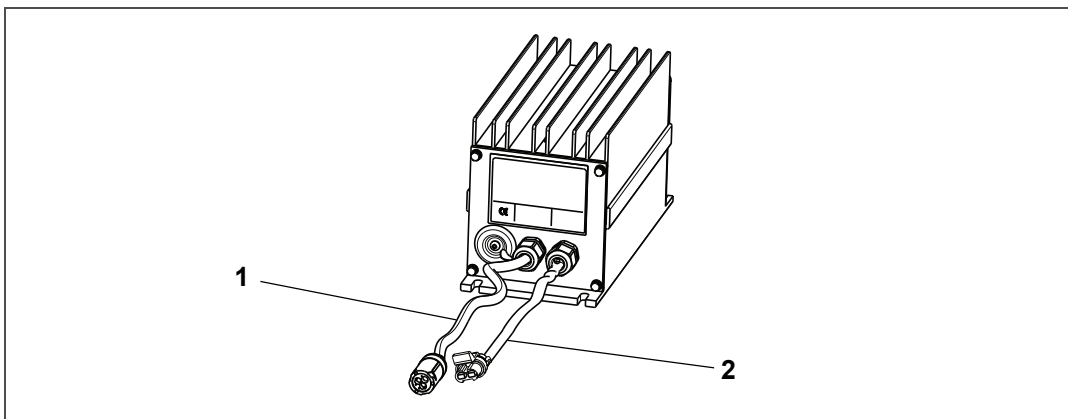
Figure 5.10 Battery Charger (PIDs Prior to UG2019)



- 1) Output +
- 2) Ground

- 3) Output -
- 4) Power Cable

Figure 5.11 Battery Charger (PIDs UG2019 and Up)



- 1) AC Wiring from Generator

- 2) DC Wiring to 12v Battery
Red (+), Black (-)

- 37. Re-secure the battery charger assembly to the unit frame.
- 38. Cut the wire-tie supporting the receptacle box to the unit frame and re-secure the receptacle box to the unit frame using bolts and washers (6). Make sure the receptacle wires are pulled through the access port in the frame, and ensure that they will be accessible to splice with the generator wires.
- 39. Place two pieces of heat shrink (1 large, 1 small) over each receptacle box wire.
- 40. Connect and butt splice the receptacle box wires with the new generator wires.
- 41. For each of the wires, shrink the small heat shrink first, and then the large heat shrink to ensure a water tight seal.
- 42. Replace and secure the two wire harnesses onto the top of the generator, secure with the bolt.
- 43. Replace the truss and the truss brackets, secure the sides with the mounting bolts (2). See [Figure 5.14](#).

NOTICE

Installing the two back truss bolts first allows the truss assembly to be pulled forward slightly, making it easier to install the two front truss bolts.

- 44. Secure the center of the truss to the isolator by installing the nuts (2) and nut plate (1).
- 45. Connect the battery.
- 46. Replace and secure the top and side panel covers.

5.6 General Generator Set Maintenance

5.6.1 Maintenance of Painted Surfaces

The unit is protected against the corrosive atmosphere in which it normally operates by a special paint system. However, if the paint system is damaged, the base metal can corrode. If the paint system is scratched or damaged, do the following:

1. Clean area to bare metal using a wire brush, emery paper or equivalent cleaning method.
2. Immediately following cleaning, spray or brush on a zinc rich primer.
3. After the primer has dried, spray or brush on finish coat of paint to match original unit color.

5.6.2 Check and Replace Isolators / Shockmounts



Continued operation with failed shockmounts may result in engine or generator damage. When a shockmount has been cut, split, abraded or has flared due to normal deterioration, it must be replaced. Damage to the mounts may not be visible when installed and under load from the component. To correctly inspect shockmounts, they must be removed.

Engine Isolator / Shockmount Replacement

1. Use the two lift eyes to lift and support the engine.
2. Remove truss, unidrive isolator and all hardware as shown in [Figure 5.14](#).
3. Remove all hardware as shown in [Figure 5.13](#).
4. Raise the engine just enough to remove the shockmounts as shown in [Figure 5.13](#).
5. Install new shockmounts.



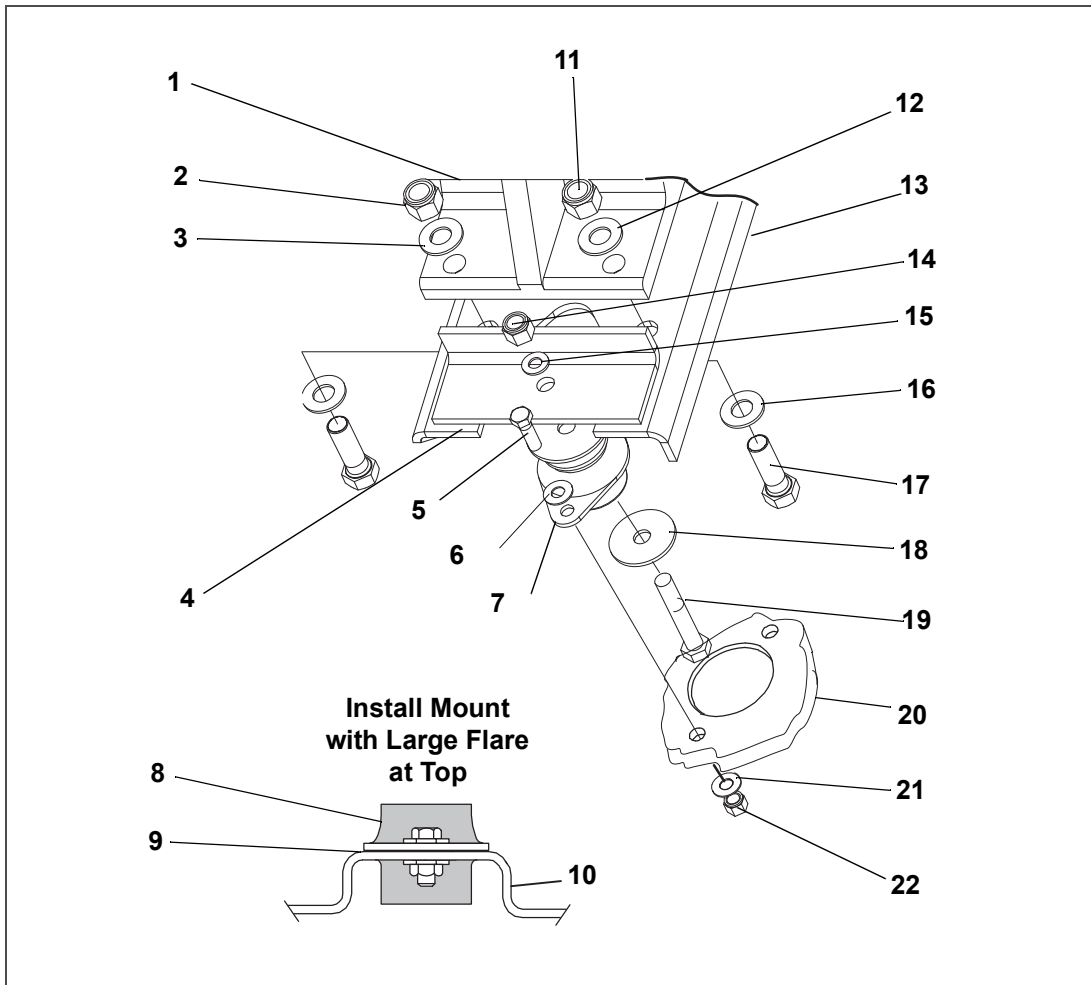
For torque values, see [Section 5.7](#).

6. Lower the engine enough to assemble hardware as shown and torque per [Section 5.7](#).
7. Remove chains from the lift eyes.

Generator Shockmount Replacement

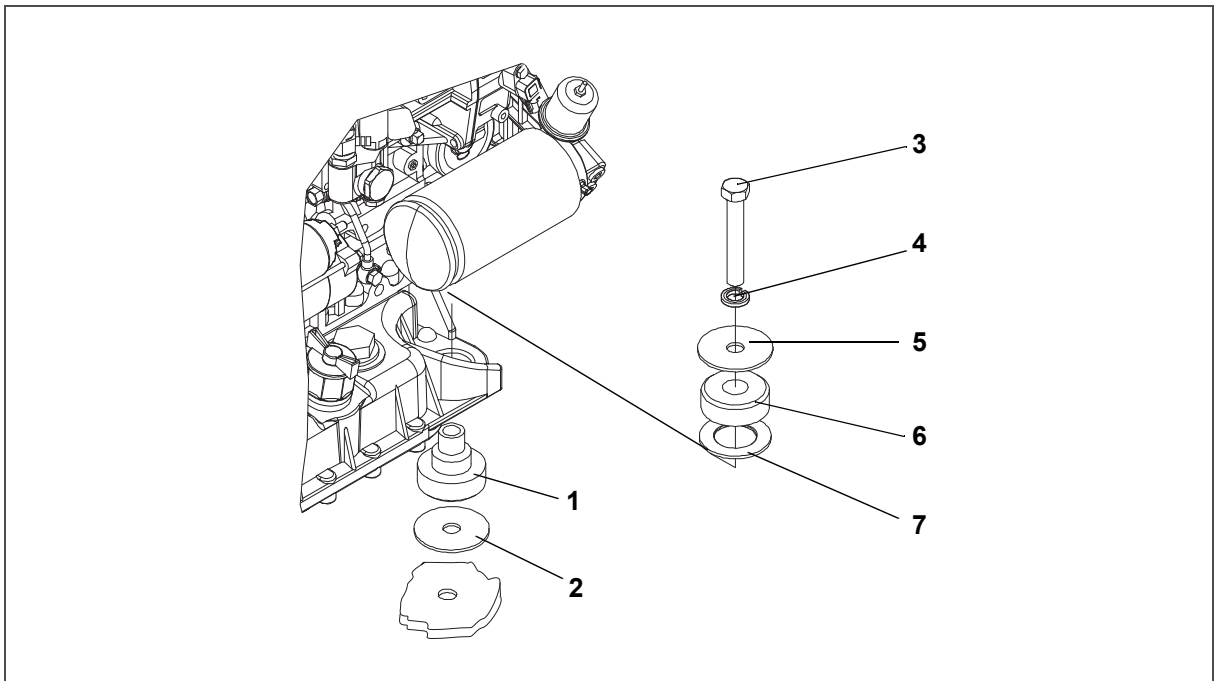
1. Use the two lift eyes to lift and support the engine.
2. Remove shockmount hardware.
3. Raise the generator just enough to remove the shockmounts as shown in [Figure 5.12](#).
4. Install new shockmounts.
5. Lower the engine enough to assemble hardware as shown and torque. See [Section 5.7](#) for torque values.
6. Remove chains from the lift eyes.

Figure 5.12 Generator Shockmounts



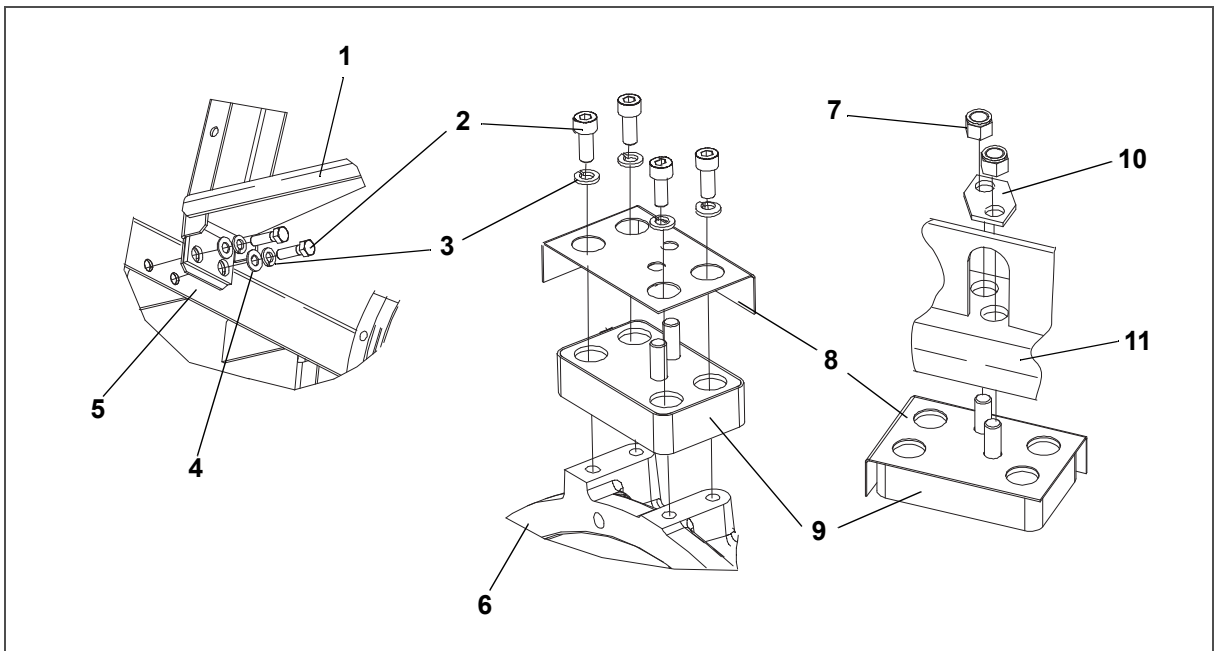
- | | |
|----------------------|-----------------------|
| 1) Generator | 12) Flat Washer (5/8) |
| 2) Locknut (5/8) | 13) Mounting Base |
| 3) Flat Washer (5/8) | 14) Locknut (1/2) |
| 4) Support Plate | 15) Flat Washer (1/2) |
| 5) Screw (3/8) | 16) Flat Washer (5/8) |
| 6) Flat Washer (3/8) | 17) Screw (5/8) |
| 7) Shockmount | 18) Snubbing Washer |
| 8) Shockmount | 19) Screw (1/2) |
| 9) Support Plate | 20) Frame |
| 10) Frame | 21) Flat Washer (3/8) |
| 11) Locknut (5/8) | 22) Locknut (3/8) |

Figure 5.13 Engine Shockmounts



- | | |
|--------------------|--------------------|
| 1) Shockmount | 5) Snubbing Washer |
| 2) Snubbing Washer | 6) Shockmount |
| 3) Bolt | 7) Flat Washer |
| 4) Lock Washer | |

Figure 5.14 Truss and Isolator



- | | |
|----------------|----------------|
| 1) Truss | 7) Locknut |
| 2) Bolt | 8) Heat Shield |
| 3) Lock Washer | 9) Isolator |
| 4) Flat Washer | 10) Nutplate |
| 5) Frame | 11) Truss |
| 6) Unidrive | |

5.7 Unidrive Torque Requirements

Extensive damage may occur if the proper hardware is not used and/or proper procedures are not followed when working with the unidrive assembly. Periodic inspection of hardware and bolt torque is recommended to ensure the integrity of the unidrive. Torque value and hardware requirements for unidrive assembly are provided in **Figure 5.15**.

NOTICE

SST is an abbreviation for **300 Series Corrosion Resistant Steel**. **Loctite #242** or an equivalent product should be used on **ALL** hardware shown in **Figure 5.15**.

Figure 5.15 Unidrive Torque Requirements

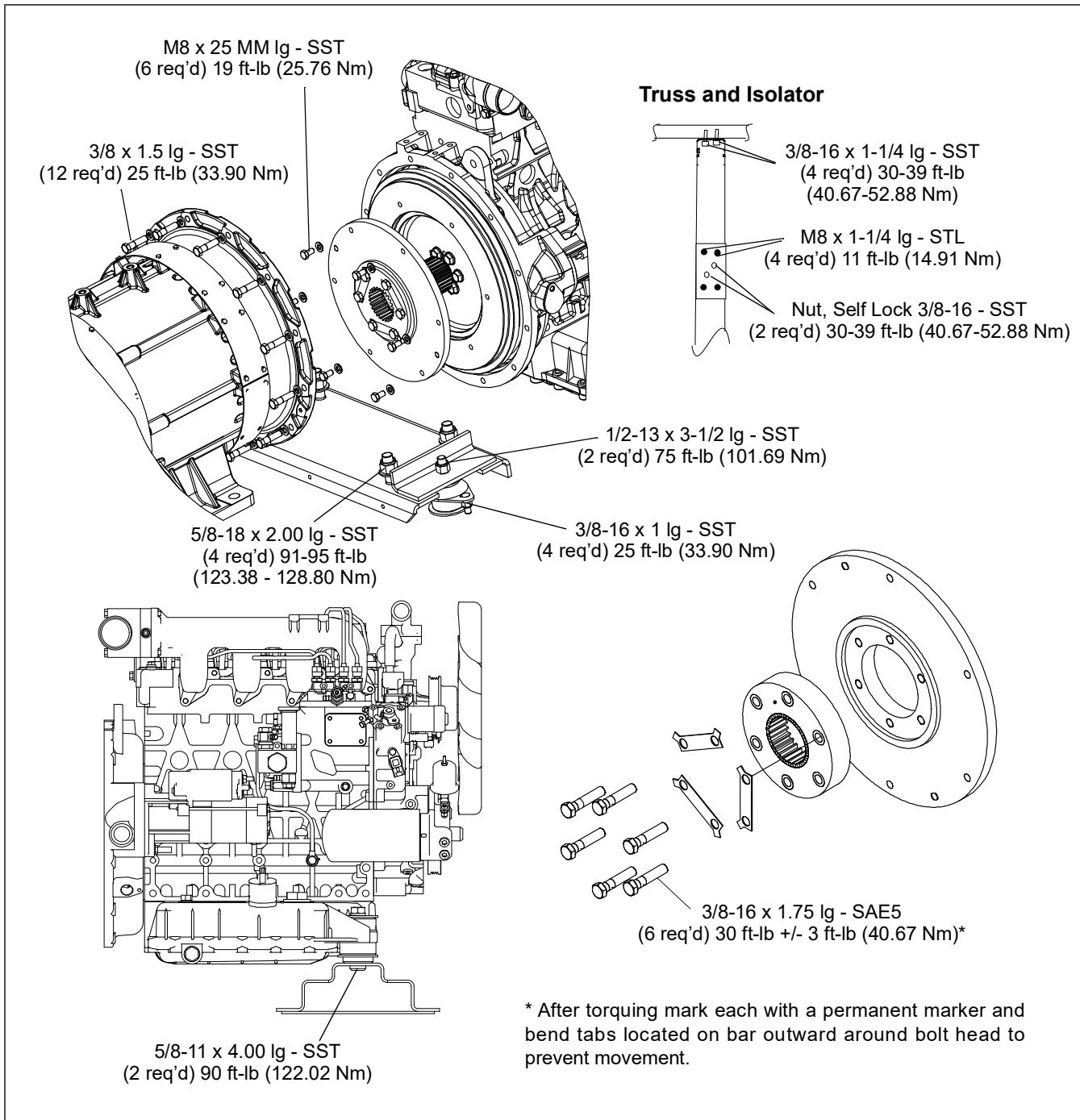


Figure 5.16 Unidrive (with Torsional Dampener) Torque Requirements

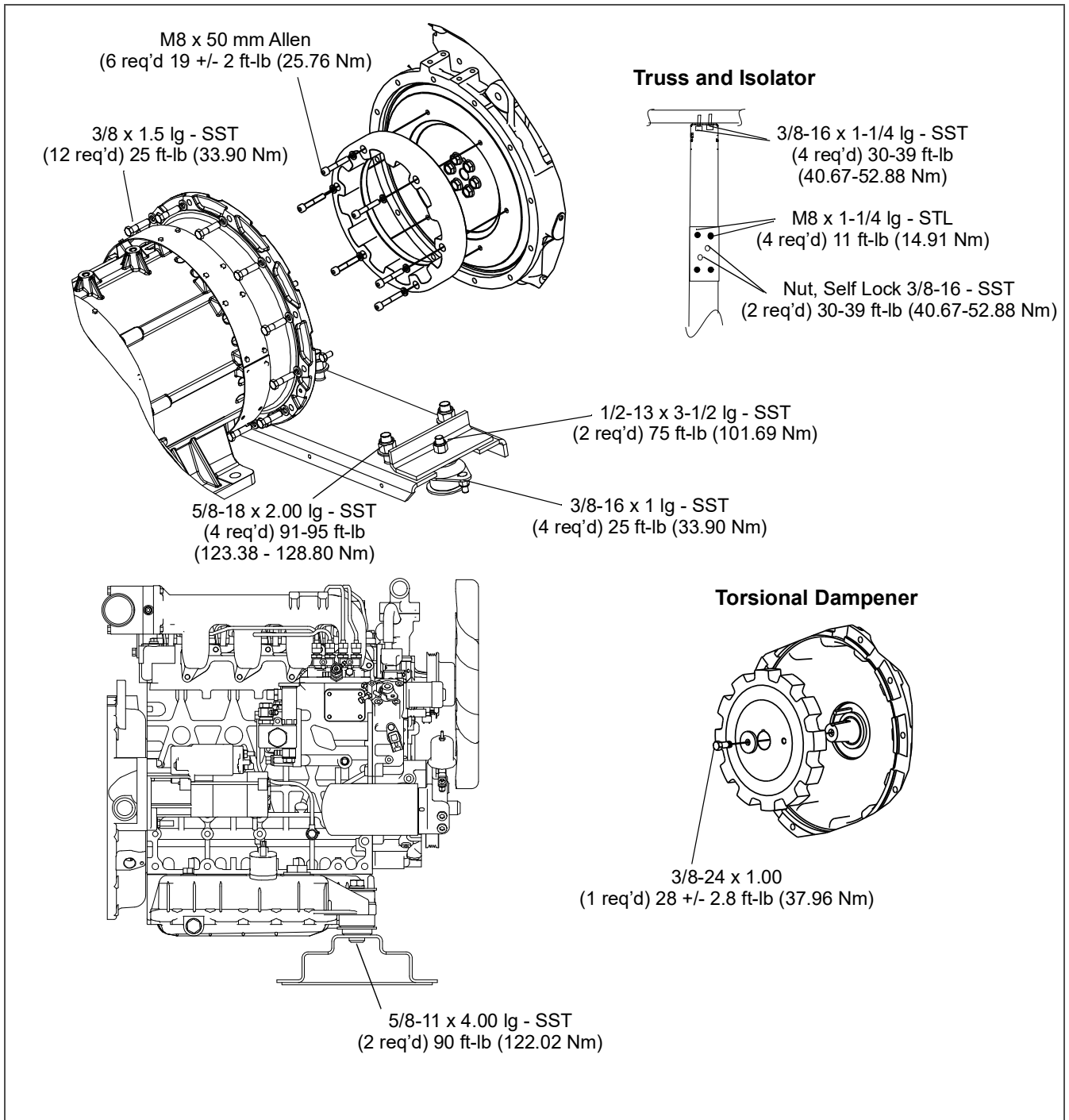


Table 5–1 Preventative Maintenance Actions and Schedule

Procedure	Manual Reference	Perform During Pre-Trip¹	Perform every 2000 hrs service²	Perform every 4000 hrs service³
1. Check (in place) Engine/Generator shockmounts for cracks, cuts, abrasion or flaring	Section 5.6.2	X	X	
2. Check engine lubrication oil and fuel lines, filters and connections for leaks.	-	X	X	X
3. Check engine lubrication oil level, add as required.	Section 2.10	X		
4. Check Poly V-belt for fraying or cracking, replace as required.	Section 5.4.11	X	X	X
5. Check radiator hoses for leaks.	-	X	X	X
6. Check coolant level add 50/50 mix as required.	Section 2.10	X	X	X
7. Check radiator coil and generator air intake for cleanliness.	Section 5.4.5	X	X	X
8. Check Air Cleaner:		X	X	X
For Oil bath air filter: Check for cleanliness and clean filter body and internal mesh. Change oil every 250 hours.	Section 5.4.12	X	X	X
For Dry element air cleaner: Check for cleanliness and clean/replace as filter indicator indicates	Section 5.4.12	X	X	X
9. Drain Water from fuel tank sump.	-	X	X	X
10. Drain Water from fuel filter bowl.	-	X	X	X
11. Fill fuel tank with diesel fuel, check fuel gauge operation.	Section 2.10	X	X	X
12. Check intake heater amperage.	Section 5.4.15	X	X	X
13. Check battery terminals for tightness and cleanliness.	-	X	X	X
14. Check for dirty loose electrical connections, frayed cables and cracked insulation.	-	X	X	X
15. Check and tighten as required all hardware, brackets etc.	-	X	X	X
16. Clean mechanical fuel lift pump internal filter.	Section 5.4.2		X	X
17. Change in line fuel filter (option).	Section 5.4.4		X	X
18. Clean and coat terminals with battery terminal sealant.	-		X	X
19. Change lubricating oil and filters (See NOTES)	Section 5.4.6		X	X
20. Tighten engine and generator mounting bolts.	Section 5.6.2		X	X
21. Tighten all electrical connections in control box.	-		X	X
22. Check water pump bearing end play.	Engine Manual		X	X
23. Change fuel filter.	Section 5.4.3		X	X
24. Check crankcase breather.	Section 5.4.13		X	X

Table 5–1 Preventative Maintenance Actions and Schedule

Procedure	Manual Reference	Perform During Pre-Trip ¹	Perform every 2000 hrs service ²	Perform every 4000 hrs service ³
25. Remove and check engine/generator shockmounts for cracks, cuts, abrasion or flaring.	Section 5.6.2		X	X
26. Clean and flush coolant system.	Section 5.4.5			X
27. Check starter condition.	Engine Manual		X	X
28. Check engine compression.	Engine Manual		X	X
29. Check and adjust injector nozzles.	Engine Manual		X	X
30. Perform generator maintenance.	Section 5.6		X	X
31. Check total time meter operation (allow engine to run 10 minutes).	-	X	X	X
32. Listen for abnormal noises.	-	X	X	X
33. Check fuel, lubricating oil and radiator coolant lines, connections and filters for leaks.	-	X	X	X
34. Check exhaust system for leaks.	-	X	X	X
35. Check with voltmeter. Generator output should be 490volts, +/- 15volts (engine, 1800rpm) with a nominal frequency of 60Hz.	Section 5.6	X	X	X
36. Turn refrigeration unit on and check generator 1800rpm under full load.	Section 5.6	X	X	X
37. Verify operation of safety devices.	Section 2.8		X	X

NOTICE

Units have mineral oil installed from the factory - change lubricating oil and filters after the first 2000 hours of service or at the end of the first year, whichever comes first.

Oil changes after the first 2000 hour service, or 1 year:

- If using mineral oil, oil changes should continue every 2000 hours of service or every 1 year, whichever comes first.
- If using specified synthetic lubricating oil and OEM extended life oil filter, oil changes should be completed every 4000 hours of service, or every two years, whichever comes first.

¹ Pre-trip maintenance checks should be carried out prior to any use of the unit (1-15 and 31-36).

² 2000 hour maintenance checks should be carried out annually or every 2000 hours, whichever comes first.

³ 4000 hour maintenance checks should be carried out every two years or every 4000 hours, whichever comes first.

SECTION 6

SCHEMATICS

6.1 Introduction

This section contains the 12-volt DC control circuit schematic and the high voltage circuitry schematics.

Figure 6.1 Schematic Diagram - Legend (PIDs prior to UG2019)



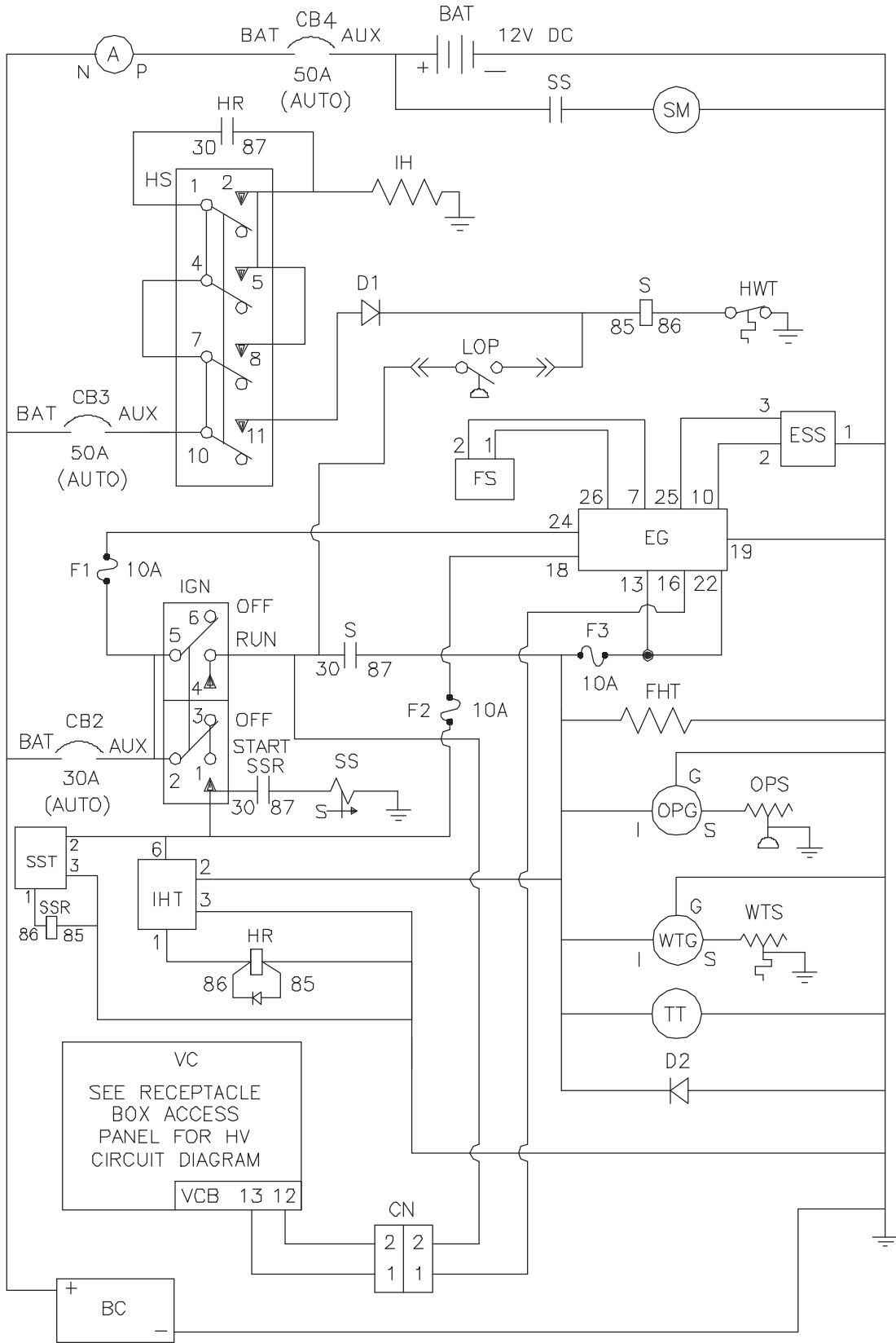
LINE	SYMBOL	LEGEND
7		SPLICE
3,4,9,10,13		ENGINE GROUND
2	A —	AMMETER
2	BAT —	BATTERY
13,14	BC —	BATTERY CHARGER
2,5,8	CB —	CIRCUIT BREAKER
13	CN —	CONNECTOR, IN-HARNESS
4,12	D —	DIODE
6	EG —	ELECTRONIC GOVERNOR MODULE
5	ESS —	ENGINE SPEED SENSOR
6,7,8	F —	FUSE
6	FS —	FUEL SOLENOID
8	FHT —	FUEL HEATER, INTEGRATED
2,10	HR —	INTAKE HEATER RELAY
3,4	HS —	HEATER SWITCH
4	HWT —	HIGH WATER TEMP. SWITCH
7,8	IGN —	IGNITION SWITCH
3	IH —	INTAKE HEATER
10	IHT —	INTAKE HEATER TIMER
5	LOP —	LOW OIL PRESS. SWITCH
9	OPG —	OIL PRESSURE GAUGE
9	OPS —	OIL PRESSURE SENDER
4,7	S —	SAFETY RELAY
2	SM —	STARTER MOTOR
—	SP —	SPLICE POINT
2,9	SS —	STARTER SOLENOID
9,10	SSR —	STARTER SOLENOID RELAY
9	SST —	STARTER SOLENOID TIMER
11	TT —	TIME METER
12	VC —	VOLTAGE CONTROLLER
10	WTG —	WATER TEMP. GAUGE
10	WTS —	WATER TEMP. SENDER

Figure 6.2 Schematic Diagram (PIDs prior to UG2019)

12VDC CONTROL CIRCUIT

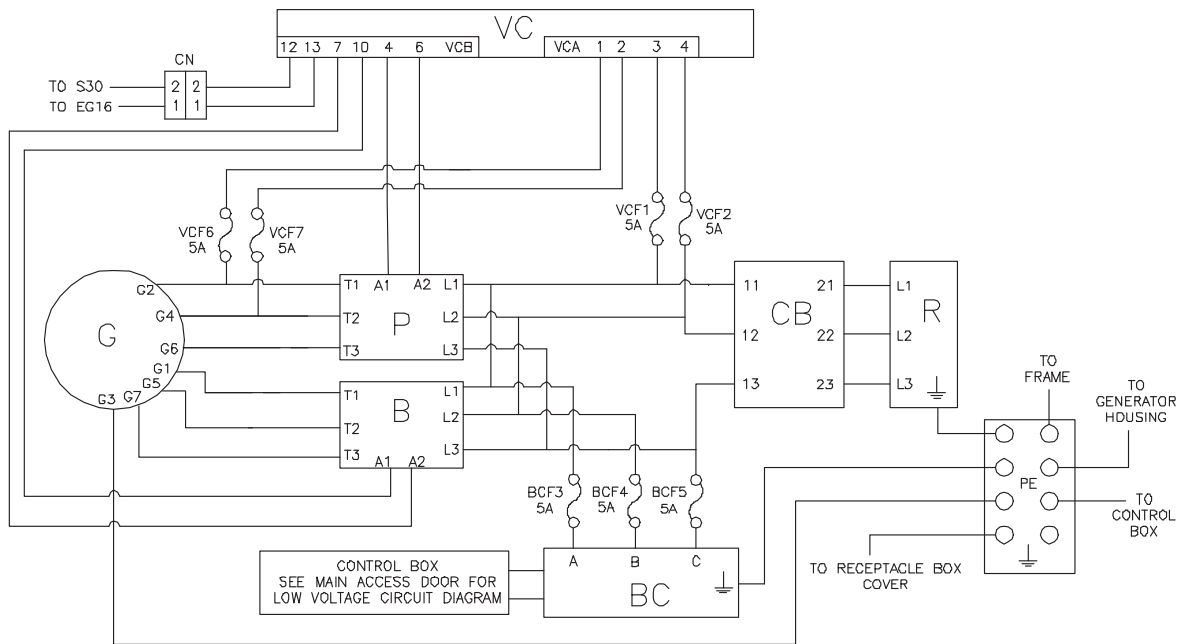
1
2
3
4
5
6
7
8
9
10
11
12
13
14




62-11725-0

Figure 6.3 Schematic High Voltage Circuitry (PIDs prior to UG2019)

HIGH VOLTAGE CIRCUITRY



SYMBOL LEGEND

	ENGINE GROUND	P	—	PRIMARY CONTACTOR	
B	—	BOOST CONTACTOR	PE	—	PHYSICAL EARTH
BC	—	BATTERY CHARGER	R	—	RECEPTACLE
BCF	—	BATTERY CHARGER FUSE	VC	—	VOLTAGE CONTROLLER
CB	—	CIRCUIT BREAKER	VCA	—	VOLTAGE CONTROLLER CONNECTOR
CN	—	CONNECTOR, IN-HARNESS	VCB	—	VOLTAGE CONTROLLER CONNECTOR
G	—	GENERATOR	VCF	—	VOLTAGE CONTROLLER FUSE

62-11732-00 REV B

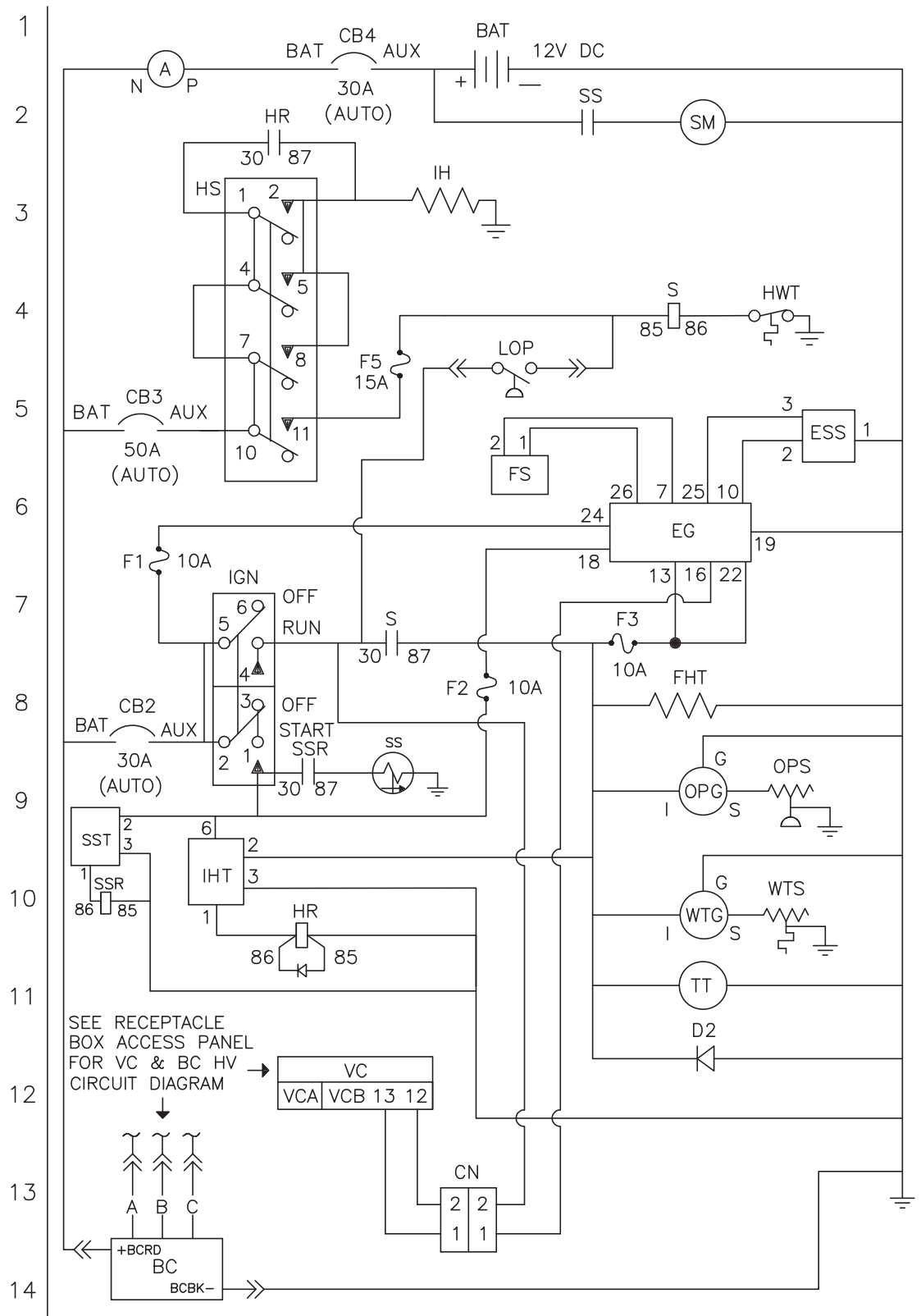
Figure 6.4 Schematic Diagram - Legend (PIDs UG2019 and Up)

LINE	SYMBOL	LEGEND
7	●	SPLICE
3,4,9,10,13	⊥	ENGINE GROUND
2	A —	AMMETER
2	BAT —	BATTERY
13,14	BC —	BATTERY CHARGER
2,5,8	CB —	CIRCUIT BREAKER
13	CN —	CONNECTOR, IN-HARNESS
12	D2 —	DIODE
6	EG —	ELECTRONIC GOVERNOR MODULE
5	ESS —	ENGINE SPEED SENSOR
5,6,7,8	F —	FUSE
6	FS —	FUEL SOLENOID
8	FHT —	FUEL HEATER, INTEGRATED
2,10	HR —	INTAKE HEATER RELAY
3,4	HS —	HEATER SWITCH
4	HWT —	HIGH WATER TEMP. SWITCH
7,8	IGN —	IGNITION SWITCH
3	IH —	INTAKE HEATER
10	IHT —	INTAKE HEATER TIMER
5	LOP —	LOW OIL PRESS. SWITCH
9	OPG —	OIL PRESSURE GAUGE
9	OPS —	OIL PRESSURE SENDER
4,7	S —	SAFETY RELAY
2	SM —	STARTER MOTOR
—	SP —	SPLICE POINT
2,9	SS —	STARTER SOLENOID
9,10	SSR —	STARTER SOLENOID RELAY
9	SST —	STARTER SOLENOID TIMER
11	TT —	TIME METER
12	VC —	VOLTAGE CONTROLLER
10	WTG —	WATER TEMP. GAUGE
10	WTS —	WATER TEMP. SENDER

62-04233-00

Figure 6.5 Schematic Diagram (PIDs UG2019 and Up)

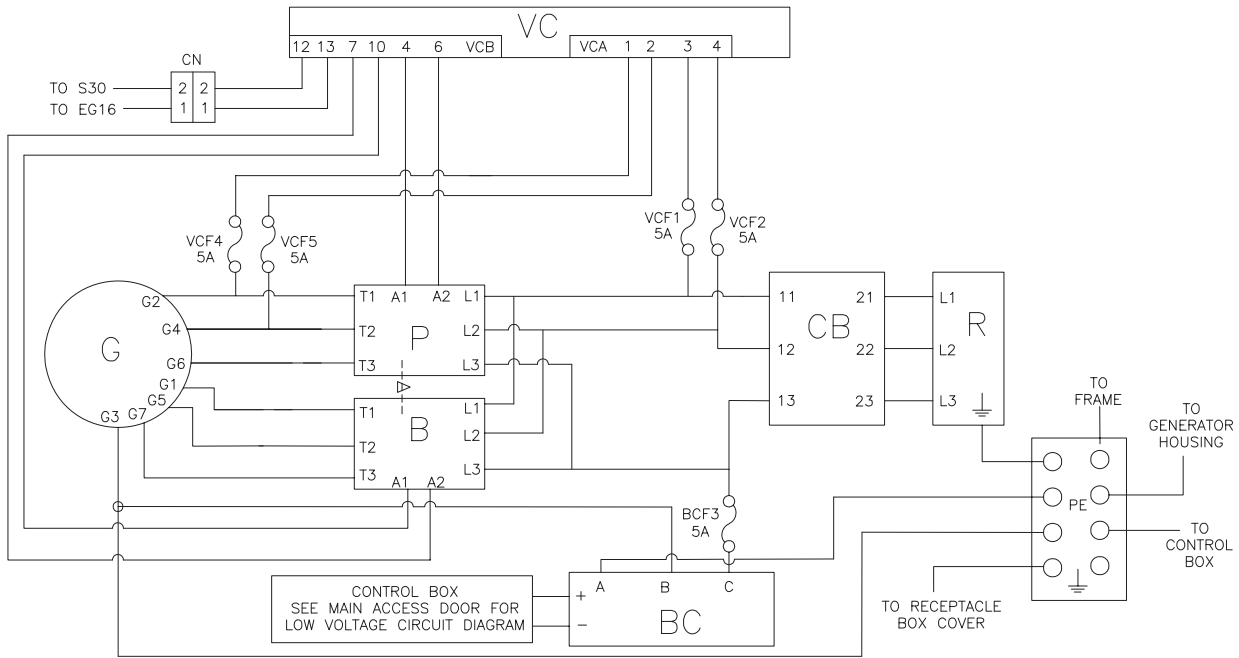
12VDC CONTROL CIRCUIT



62-04233-00

Figure 6.6 Schematic High Voltage Circuitry - 7 Wire Generator (PID UG2019)

HIGH VOLTAGE CIRCUITRY



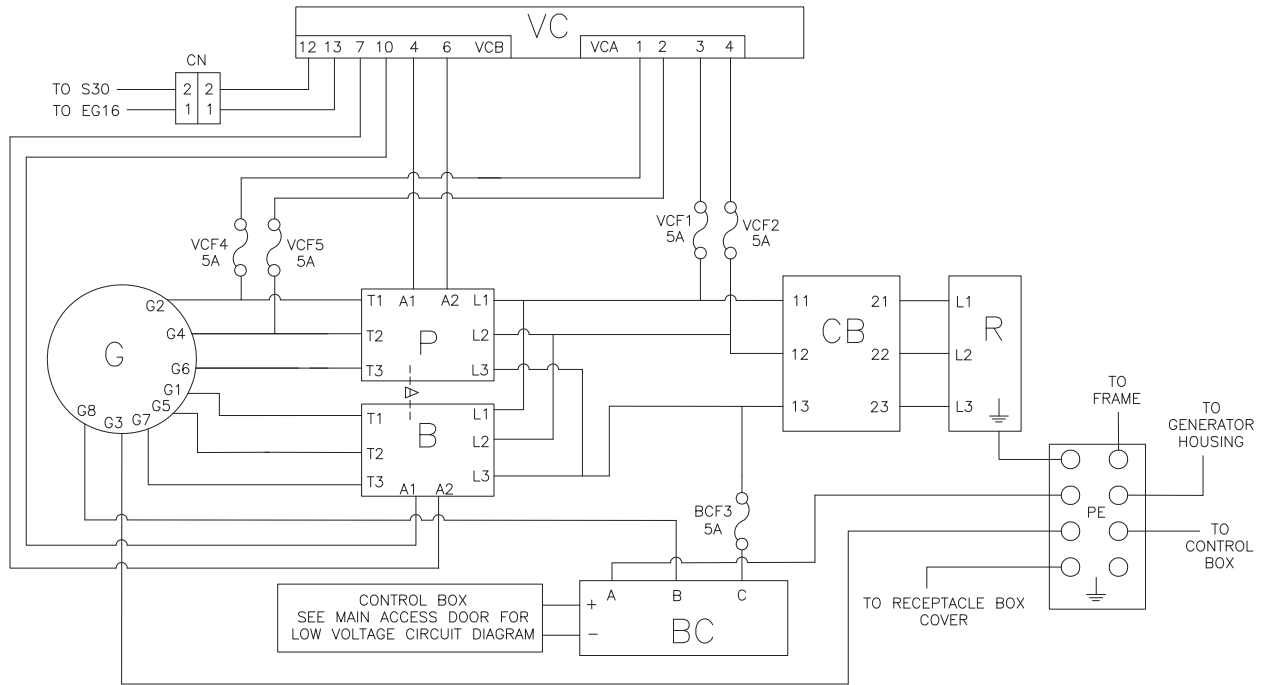
SYMBOL LEGEND

	ENGINE GROUND	P	—	PRIMARY CONTACTOR	
B	—	BOOST CONTACTOR	PE	—	PHYSICAL EARTH
BC	—	BATTERY CHARGER	R	—	RECEPTACLE
BCF	—	BATTERY CHARGER FUSE	●	—	SPLICE
CB	—	CIRCUIT BREAKER	VC	—	VOLTAGE CONTROLLER
CN	—	CONNECTOR, IN-HARNESS	VCA	—	VOLTAGE CONTROLLER CONNECTOR
G	—	GENERATOR	VCB	—	VOLTAGE CONTROLLER CONNECTOR
MI	—	MECHANICAL INTERLOCK	VCF	—	VOLTAGE CONTROLLER FUSE
				—	INTERLOCK



62-04232-00

Figure 6.7 Schematic High Voltage Circuitry - 8 Wire Generator (PIDs UG2020 and Up)

HIGH VOLTAGE CIRCUITRY



SYMBOL LEGEND

	ENGINE GROUND	P	—	PRIMARY CONTACTOR	
B	—	BOOST CONTACTOR	PE	—	PHYSICAL EARTH
BC	—	BATTERY CHARGER	R	—	RECEPTACLE
BCF	—	BATTERY CHARGER FUSE	●	—	SPLICE
CB	—	CIRCUIT BREAKER	VC	—	VOLTAGE CONTROLLER
CN	—	CONNECTOR, IN-HARNESS	VCA	—	VOLTAGE CONTROLLER CONNECTOR
G	—	GENERATOR	VCB	—	VOLTAGE CONTROLLER CONNECTOR
MI	—	MECHANICAL INTERLOCK	VCF	—	VOLTAGE CONTROLLER FUSE
				—	INTERLOCK

62-04235-00

INDEX

A

AC Generator 5–8
Air Cleaner Body 5–6
Air Cleaner, Dry Element 5–5
Air Cleaner, Oil Bath Service 5–5
Air Filter Indicator 5–5
Alternating Current Generator 2–9, 4–5
Auto Re-Start Option 4–6

B

Battery Charger 5–12
Battery Charger (Solid State) 4–4
Battery Charging System 2–9
Battery Service 5–1
Bleeding the Fuel System 5–1

C

Configuration Identification 2–1
Cooling System 5–2

D

Description 2–1
Diesel Engine 4–1

E

Electronic Governor Module 2–8, 4–7
Engine Air Cleaner 5–4
Engine Air System 2–8
Engine Crankcase Breather 5–6
Engine Data 2–17
Engine Screw Threads 2–8
Engine Service and Components 5–1
Engine Speed 5–4
Engine Speed Sensor 5–4
Engine Starts Then Stops 4–2
Engine Will Not Shut Off 4–2
Engine Will Not Start 4–1

F

First Aid 1–1
Fuel Filter 5–2

G

General Generator Set Maintenance 5–13
General Safety Notices 1–1
Generator Set Installation 3–1
Generator Set Removal 3–1

H

Heater Test 5–7
High Voltage Circuit 4–8

I

In-Line Fuel Strainer 5–2
Instruments 2–9
Intake Heater 5–7
Intake Heater Switch 5–8
Introduction 2–1
Isolators/Shockmounts 5–13

L

Low Coolant Sensor 5–3
Lube Oil 2–9
Lube Oil Filter 5–3
Lube Oil Filter Arrangement 2–9

M

Maintenance Precautions 1–1
Malfunction In The Engine Starting Circuit 4–3
Miscellaneous Engine Troubleshooting 4–4

O

Oil Pressure Switch 5–3
Operating Controls 2–9
Operating Precautions 1–1

P

Painted Surfaces 5–13
Poly V-belt 5–4
Post-Start Inspection 3–5
Pre-Start Inspection 3–4
Preventative Maintenance Actions and Schedule 5–18

Q

Quick Mount 3–3

S

Safety Devices 2–15
Safety Summary 1–1
Schematic Diagram 6–2
Schematic Diagram - Legend 6–1, 6–4
Schematic High Voltage Circuitry 6–3, 6–6
Schematics 6–1
Sequence of Operation Warning 3–5
Servicing Fuel Pump Internal Filter 5–2

Shockmounts 5–15
Standard Mount 3–2
Starter Motor Malfunction 4–3
Starting and Stopping Instructions 3–4
Starting Instructions 3–4
Stopping Instructions 3–5

T

Troubleshooting 4–1

Truss and Isolator 5–15

U

UniDrive Torque Requirements 5–16
Unit Specifications 2–17

V

Voltage Controller 2–9, 4–7



Carrier Transicold Division,
Carrier Corporation
P.O. Box 4805
Syracuse, NY 13221 USA

<https://www.carrier.com/container-refrigeration>