

SGCO 3000 (233) 2011

MAEG302598 - MAEG302830

TK 55076-4-MM (Rev. 0, 04/11)

The maintenance information in this manual covers unit models:

SGCO (062007): Model with SG+ controls and clip-on unit frame

SGCO (062009) Model with SG+ controls and clip-on unit frame

For further information, refer to:

SGCO 3000 Parts Manual

TK 53717

TK482 and TK486 Engine Overhaul Manual

TK 50136

Electrostatic Discharge (ESD) Training Guide

TK 40282

Tool Catalog

TK 5955

The information in this manual is provided to assist owners, operators and service people in the proper upkeep and maintenance of Thermo King units. This Thermo King family of generator sets includes one model: SGCO. When maintenance information differs between models, this manual uses the model nomenclature (e.g. SGCO) to indicate that the information applies to specific units only. In addition, the model nomenclature indicates the following:

Model Nomenclature

Unit Feature

CO..... Clip-on unit frame

This manual is published for informational purposes only and the information so provided should not be considered as all-inclusive or covering all contingencies. If further information is required, Thermo King Corporation should be consulted.

Sale of product shown in this manual is subject to Thermo King's terms and conditions including, but not limited to, the Thermo King Limited Express Warranty. Such terms and conditions are available upon request. Thermo King's warranty will not apply to any equipment which has been "so repaired or altered outside the manufacturer's plants as, in the manufacturer's judgment, to effect its stability."

No warranties, express or implied, including warranties of fitness for a particular purpose or merchantability, or warranties arising from course of dealing or usage of trade, are made regarding the information, recommendations, and descriptions contained herein. Manufacturer is not responsible and will not be held liable in contract or in tort (including negligence) for any special, indirect or consequential damages, including injury or damage caused to vehicles, contents or persons, by reason of the installation of any Thermo King product or its mechanical failure.

Recover Refrigerant

At Thermo King, we recognize the need to preserve the environment and limit the potential harm to the ozone layer that can result from allowing refrigerant to escape into the atmosphere.

We strictly adhere to a policy that promotes the recovery and limits the loss of refrigerant into the atmosphere.

In addition, service personnel must be aware of Federal regulations concerning the use of refrigerants and the certification of technicians. For additional information on regulations and technician certification programs, contact your local Thermo King dealer.

Table of Contents

List of Figures	9
SGCO 3000 Genset Addendum	11
Genset Model Features	13
Safety Precautions	15
General Practices	15
Battery Hazards	15
Precautions	15
First Aid	15
Electrical Hazards	15
High Voltage	15
Precautions	16
First Aid	16
Low Voltage	16
General Safety Precautions for Servicing Units (or Containers) Equipped with a Microprocessor Controller ..	17
Controller Repair	17
Welding of Units or Containers	17
Safety Do's and Don'ts	17
DO:	17
DO NOT	18
Serial Number Locations	19
Unit Decals	20
Service Guide	21
Specifications	23
Engine	23
Generator	23
Electrical Control System	24
Electrical Components	24
Controller Default Settings	24
Physical Specifications	25
Metric Hardware Torque Charts	26
Unit Description, Features & Options	27
General Description	27
EMI 3000 Package	28
SG+ Microprocessor Controller	28
Unit Instruments	28
Unit Protection Devices	29
Dual Voltage Option	29
EcoPower Option	29
Fuel Level Sensor Option	29
Additional Options	29
Controller Description	33
SG+ Controller Description	33
Controller Overview	35
Miscellaneous Features	36
Navigating the Controller Menus	37
Controller Display Menus	37
Navigating Controller Menus	37
Menu Overview	38
Data Menu	39
Alarm List Menu	39
Message List Menu	39
Commands Menu	39
Misc. Functions Menu	39
Configuration Menu	39

Table of Contents

Event Log Menu	39
Standard Display	40
Pause Mode Displays	40
Network Down Display	40
Operating Instructions	41
Pretrip Inspection	41
Visual Inspection	41
Starting the Unit	42
After Start Inspection	43
Functional Inspection	43
Main Menu	45
Data Menu	46
Analog Inputs	47
Digital Inputs	48
Digital Outputs	49
Internal States	50
Alarm List Menu	51
Alarm Types	51
Displaying and Acknowledging Alarms	51
Alarm Diagnosis	51
Message List Menu	54
Displaying and Acknowledging Messages	54
Message Diagnosis	54
Commands Menu	58
PTI	59
Manual Function Test	60
System Setup	62
Date/Time	64
Misc. Functions Menu	65
C/F Mode	66
SW/HW Version	67
Timers/Counters	68
Configuration Menu	69
Setting Hour Meter Thresholds and Resetting Hour Meters	72
Event Log Menu	73
Event Log	74
Fuel Events	74
LogView and Viewing SG+ Logs	76
Electrical Maintenance	79
Battery	79
Relays	79
Fuel Pull Relay	79
Fuel Hold Relay	79
Speed (Throttle) Solenoid Relay	79
Start Relay	80
Preheat Relay	80
Unit Wiring	80
12 Vdc Charging System	80
Air Heater	81
Engine Low Oil Pressure Switch	81
Oil Level Sensor	82
Switch Test	82
Switch Removal and Installation	82
Bench Test	82
Coolant Temperature Sensor	83
Sensor Test	83
Coolant Level Detector Sensor	84
Sensor Test	84

Flywheel Sensor	85
Testing the Flywheel Sensor	85
Engine Maintenance	87
EMI 3000	87
Engine Lubrication System	87
Engine Oil Change	87
Oil Filter Change	87
Low Oil Pressure	88
Crankcase Breather	89
Cyclonic Dry Air Cleaner	90
Air Restriction Indicator	90
Engine Cooling System	91
ELC (Extended Life Coolant)	91
Antifreeze Maintenance Procedure	93
Checking the Antifreeze	93
Changing the Antifreeze	93
Bleeding Air from the Cooling System	94
Engine Thermostat	95
Engine Fuel System	95
Maintenance	95
Fuel Return Line Replacement	97
Bleeding the Fuel System	97
Water in the Fuel System	98
Single Element Fuel Filter/Water Separator Replacement	98
Draining Water from Fuel Tank	98
Fuel Strainer	98
Engine Speed Adjustment	99
Adjustment Procedure for Standard Units	99
Adjustment Procedure for Units with EcoPower Option	99
Integral Fuel Solenoid	100
Diagnosing the Integral Fuel Solenoid System	100
Fuel Solenoid Replacement	102
Injection Pump Service and Timing	103
Injection Pump Removal	103
Injection Pump Installation	104
Injection Pump Timing	105
Trochoid Feed Pump	108
Cold Start Device	109
Adjusting Engine Valve Clearance	111
Belt Tension Adjustment and Belt Replacement	113
Alternator Operation and Diagnosis	115
General Description	115
Dual Voltage Alternator	115
Alternator Function	116
Starting Excitation	116
Running Excitation and Control	116
Battery Charging	116
Overload Shutdown	116
Alternator Diagnosis	117
Preliminary Checks	117
Test Instruments	117
Alternator Troubleshooting	117
Test 1 - Determine if Problem is in Controller or Alternator	118
Test 2 - Controller Excitation Test	118
Test 3 - Testing Alternator	119
Test 4 - Alternator Exciter Field Testing	119
Test 5 - Alternator Stator Testing	119
Megohmmeter	120

Table of Contents

Maintenance Procedures	121
General Inspection	121
Insulation	121
Field Coils, Stator Windings	121
Generator Housing	121
Generator Bearing	121
Impeller Fan	121
Coupling	121
Rewiring Procedures for Changing the Generator Set Output Voltage	123
Rewiring Procedure for Changing the Output Voltage from 460 Vac to 230 Vac	123
Structural/Accessory Maintenance	125
Unit Inspection	125
Mounting Bolts	125
Radiator Fan Location	125
SGCO 3000 Clip-on Corner Clamp Unit Installation	126
SGCO 3000 Clip-on Header Pin Unit Installation	128
Unit Inspection	129
Radiator Coil	129
Mechanical Diagnosis	131
Index	135
Electrical and SG+ Menu Flow Diagrams	139
CONTROLLER MENU GUIDE	143

List of Figures

Figure 1: Maersk Equipment Number Located On Vertical Frame Member Behind Alternator	11
Figure 2: Model SGCO 3000 Decals	20
Figure 3: SGCO 3000 Clip On Generator	27
Figure 4: SG+ Controller Display	28
Figure 5: EcoPower Decal	29
Figure 6: SGCO 3000 — Unit Front View	30
Figure 7: Powerpack (All Models) — Unit Front View	31
Figure 8: SG+ Controller Display	33
Figure 9: SG+ Microprocessor	34
Figure 10: Control Box Cover	35
Figure 11: Controller Display	37
Figure 12: Menu Structure	38
Figure 13: Standard Display and Main Menu	40
Figure 14: Typical Pause Mode Display	40
Figure 15: Network Down Display	40
Figure 16: Main Menu	45
Figure 17: Data Menu	46
Figure 18: Analog Inputs	47
Figure 19: Digital Inputs	48
Figure 20: Digital Outputs	49
Figure 21: Internal States	50
Figure 22: Alarm List Menu	51
Figure 23: Message List Menu	54
Figure 24: Commands Menu	58
Figure 25: PTI Submenu	59
Figure 26: Manual Function Test Submenu	61
Figure 27: System Setup Submenu	63
Figure 28: Date/Time	64
Figure 29: Misc. Functions Menu	65
Figure 30: C/F Mode	66
Figure 31: SW/HW Version	67
Figure 32: Timers/Counters	68
Figure 33: Configuration Menu (Page 1)	70
Figure 34: Configuration Menu (Page 2)	71
Figure 35: Event Log Menu	73
Figure 36: Event Log Submenu	74
Figure 37: Fuel Events Submenu	75
Figure 38: Example of SG+ Log	77
Figure 39: Components Inside Control Box	79
Figure 40: Relay Locations	80
Figure 41: Alternator Exciter Field Coils	80
Figure 42: Air Heater	81
Figure 43: Engine Oil Pressure Switch	81
Figure 44: Oil Level Sensor	82
Figure 45: Coolant Temperature Sensor	83
Figure 46: Coolant Level Detector Sensor	84
Figure 47: Flywheel Sensor Location	85
Figure 48: Flywheel Sensor with Wiring and Schematic Symbols	85
Figure 49: Crankcase Breather	89
Figure 50: Cyclonic Dry Air Cleaner	90
Figure 51: Cyclonic Dry Air Cleaner	90
Figure 52: Air Restriction Indicator	90
Figure 53: ELC Nameplate Located On Expansion Tank	91
Figure 54: SGCO Engine Cooling System	92
Figure 55: Remove Plug from Water Pump	94
Figure 56: Engine Thermostat	95
Figure 57: Fuel System	96
Figure 58: Fuel Return Line Replacement Decal	97

List of Figures

Figure 59: Fuel Return Line Replacement	97
Figure 60: Injection Pump	97
Figure 61: Fuel Strainer Components	99
Figure 62: Engine Speed Adjustment for Standard Unit	99
Figure 63: Engine Speed Adjustment for Units with EcoPower Option	100
Figure 64: Integral Fuel Solenoid Harness Connections	100
Figure 65: Integral Fuel Solenoid Components	102
Figure 66: Index Mark Location	103
Figure 67: Index Mark Alignment	103
Figure 68: Injection Pump Gear Tool	104
Figure 69: Index Mark Location	105
Figure 70: Index Mark Alignment	105
Figure 71: Marking Gear Case	105
Figure 72: Place Injection Angle Sticker on Gear Case	105
Figure 73: Injection Angle Sticker	105
Figure 74: Removing Injection Pump Gear	106
Figure 75: Injection Angle Mark Location	106
Figure 76: Injection Angle Mark	106
Figure 77: Injection Pump Serial Number Location	106
Figure 78: Examples of Injection Pump Index Mark Alignment with Injection Angle Sticker	107
Figure 79: Timing Mark Alignment	107
Figure 80: Align Flat Sides of Crankshaft Gear with Flat Sides of Inner Rotor in Timing Gear Cover	107
Figure 81: Trochoid Feed Pump Location	108
Figure 82: Trochoid Feed Pump Removal	108
Figure 83: Trochoid Feed Pump	109
Figure 84: Cold Start Device	109
Figure 85: Remove Engine Coolant Fitting	110
Figure 86: Remove Cold Start Device	110
Figure 87: Clean Piston	110
Figure 88: Adjusting the Valve Clearance	111
Figure 89: Timing Marks	111
Figure 90: Valve Adjustment and Cylinder Configurations	112
Figure 91: Water Pump Fan Belt	113
Figure 92: 460/230 Vac Alternator Component Function	115
Figure 93: Remove Blue Cap	118
Figure 94: Check Voltage Between J15 and J16	118
Figure 95: DATA MENU/ANALOG INPUTS	119
Figure 96: Alternator Stator	119
Figure 97: Rectifying Diodes	119
Figure 98: Exciter Armature	120
Figure 99: Main Field Winding	120
Figure 100: Alternator Assembly	122
Figure 101: Changing Output Voltage	123
Figure 102: Radiator Fan Blade Placement	125
Figure 103: SGCO 3000 Clip-on Corner Clamp Installation	126
Figure 104: SGCO 3000 Clip-on Corner Clamp Installation Procedure	127
Figure 105: SGCO Clip-on Header Pin Mounting Installation	128

SGCO 3000 Genset Addendum

Fuel Strainer option added to the following units:

MAEG302598 - MAEG302830

Figure 1: Maersk Equipment Number Located On Vertical Frame Member Behind Alternator



Genset Model Features

Genset Model Features

SGCO	MODEL
S	TK486V Diesel Engine
S	460 Vac Output for 15 KW, 18.75 KVA, 3 Phase, 60 Hz, 4 Wire Generator
O	230 Vac Output for 15 KW, 18.75 KVA, 3 Phase, 60 Hz, 4 Wire Generator
S	SG+ Control System
S	Battery, Post Style
S	Battery Charging System, Solid-state
S	Clip-on Unit Frame
S	Combination Fuel Filter/Water Separator
S	Dry Air Cleaner
S	Silicone Coolant Hoses
S	Stainless Steel Muffler
O	Fuel Heater Electric
O	Header Pin, Mounting
S	EMI 3000 Extended Maintenance Interval Package
S	Integral 125 Gallon (473 Liter) Steel Fuel Tank
O	Fuel Strainer
S = STD O = Optional	

Safety Precautions

General Practices

1. Always Wear Goggles Or Safety Glasses. Battery acid can permanently damage the eyes (see First Aid under Battery Hazards).
2. Keep your hands, clothing and tools clear of all fans, pulleys and belts when the unit is running. Be very careful with tools or meters to avoid contacting the rotor, if it is necessary to run the alternator with the end cover removed.
3. Be sure all mounting bolts are tight and the correct length for their particular application.
4. Use extreme caution when drilling holes in the unit. The holes may weaken structural components. Holes drilled into electrical wiring can cause fire, explosion or shock hazard.
5. Use caution when working around exposed coil fins. The fins can cause painful lacerations.
6. Do not work on a generator set in a confined area. Diesel exhaust can become very dangerous under certain conditions.

Battery Hazards

Few people realize just how dangerous a battery can be. The electrolyte in a lead acid battery is dilute sulfuric acid (H_2SO_4). During charge or discharge functions of a battery, a chemical change takes place within the individual cells. This causes the gas bubbling we see through the filler hole. The bubbling gases are hydrogen and oxygen. They are EXPLOSIVE. An explosion could occur if a means of ignition is present during this gassing action. A defective battery may suddenly explode even while standing idle. Added to this danger, is the fall-out of highly corrosive sulfuric acid caused by the explosion. A rubber blanket or other cover can be used to reduce the risk of injury from a possible explosion.

Precautions

1. Always wear eye protection when servicing a battery. If electrolyte is splashed on the skin or in the eyes, flush immediately under running water. Obtain medical help as soon as possible.
2. Do not remove the vent caps when charging a battery.
3. Make sure the On/Off switch is in the OFF position when disconnecting or connecting the generator set battery. This will prevent an electrical arc which could cause the battery to explode. Disconnect the ground cable first, preferably at a point AWAY FROM THE BATTERY. Connect the ground cable last, again away from the battery if possible.
4. Do not check a battery by shorting (sparking) across the battery posts. Eye injury may result from the electrical arc or from an explosion.

First Aid

- EYES: Immediately flush eyes with large amounts of water while holding the eyelids open for at least 15 minutes. Get prompt medical attention.
- SKIN: Remove contaminated clothing. Wash thoroughly with soap and water. Get medical attention if irritation persists.

Electrical Hazards

High Voltage

The possibility of serious or even fatal injury from electrical shock exists, when servicing or repairing a generator set. Extreme care must be used when working with an operating generator set. Lethal voltage potentials can exist at the unit power cord, inside the exciter control box, inside any high voltage junction box and within the wiring harnesses.

Precautions

1. Turn the generator set On/Off switch to OFF before connecting or disconnecting a power plug to the generator set receptacle. Never attempt to stop a refrigeration unit by disconnecting the power plug from an operating generator set.
2. Be certain a unit power plug is clean and dry before connecting it to the generator set receptacle.
3. Use tools with insulated handles that are in good condition. Never hold metal tools in your hand if exposed, energized conductors are within reach.
4. Stand on a solid work platform with rubber mats or dry wood if possible. If you slip, you can instinctively grab for support. This can be lethal when working on a generator set.
5. Do not make any rapid moves when working on high voltage circuits. If a tool or other object falls, do not attempt to grab it. People do not contact high voltage wires on purpose. It occurs from an unplanned movement.
6. Treat all wires and connections as high voltage until a meter and wiring diagram show otherwise.
7. Never work alone on high voltage circuits on the generator set. Another person should always be standing by in the event of an accident to shut off the generator set and to aid a victim.
8. Have electrically insulated gloves, cable cutters and safety glasses available in the immediate vicinity in the event of an accident.

First Aid

IMMEDIATE action must be initiated after a person has received an electrical shock. Obtain immediate medical assistance if available.

The source of shock must be immediately removed by either shutting down the power or removing the victim from the source. If it is not possible to shut off the power, the wire should be cut with either an insulated instrument (e.g., a wooden handled axe or cable cutters with heavy insulated handles) or by a rescuer wearing electrically insulated gloves and safety glasses. Whichever method is used, do not look at the wire while it is being cut. The ensuing flash can cause burns and blindness.

If the victim has to be removed from a live circuit, pull the victim off with a non-conductive material. Use the victim's coat, a rope, wood, or loop your belt around the victim's leg or arm and pull the victim off. **DO NOT TOUCH** the victim. You can receive a shock from current flowing through the victim's body.

After separating the victim from the power source, check immediately for the presence of a pulse and respiration. If a pulse is not present, start CPR (Cardio Pulmonary Resuscitation) and call for emergency medical assistance. If a pulse is present, respiration may be restored by using mouth-to-mouth resuscitation, but call for emergency medical assistance.

Low Voltage

Control circuits are low voltage (12 Vdc). This voltage potential is not considered dangerous, but the large amount of current available (over 30 amperes) can cause severe burns if shorted to ground.

Disconnect the negative terminal of the battery if possible when working on the generator set. Disconnect the cable end that is away from the battery.

Do not wear jewelry, watches or rings. These items can short out and cause severe burns to the wearer.

General Safety Precautions for Servicing Units (or Containers) Equipped with a Microprocessor Controller

Precautions must be taken to prevent electrostatic discharge during service of the SG+ microprocessor controller and related components. The risk of significant damage to the electronic components of the unit is possible if these precautionary measures are not followed.

The primary risk potential results are as follows:

- The failure to wear adequate electrostatic discharge preventive equipment when handling and servicing the controller.
- Electric welding on the unit and/or container chassis without taking precautionary steps.

Controller Repair

It's necessary to ensure that electrostatic discharges are avoided when servicing the controller. Potential differences considerably lower than those which produce a small spark from a finger to a door knob can severely damage or destroy solid-state integrated circuit components. The following procedures must be rigidly adhered to when servicing these units to avoid controller damage or destruction.

1. Turn the generator set OFF.
2. Disconnect the negative terminal of the battery. Disconnect the cable end that is away from the battery.
3. Avoid wearing clothing that generates static electricity (wool, nylon, polyester, etc.).
4. Wear a static discharge wrist strap (TK P/N 204-622) with the lead end connected to the controller's ground terminal. These straps are available at most electronic equipment distributors. DO NOT wear these straps with power applied to the unit.
5. Avoid contacting the electronic components on the unit circuit boards.
6. Leave the circuit boards in their static proof packing materials until ready for installation.

7. If a defective controller is to be returned for repair, it should be returned in the same static protective packing materials from which the replacement component was removed.
8. After servicing the circuit board and any other circuits, the wiring should be checked for possible errors before restoring power.

Welding of Units or Containers

It is necessary to ensure that welding currents are NOT allowed to flow through the electronic circuits of the unit. This includes whenever electric welding is to be performed on any portion of the generator set, container or container chassis with the generator set attached. These procedures must be rigidly adhered to when servicing these units to avoid damage or destruction.

1. Disconnect all power to the generator set.
2. Disconnect all wire harnesses from the microprocessor.
3. Switch all of the electrical circuit breakers in the control box to the OFF position.
4. Weld unit and/or container per normal welding procedures. Keep ground return electrode as close to the area to be welded as practical. This will reduce stray welding currents passing through any electrical or electronic circuits.
5. When the welding operation is completed, the unit power cables, wiring and circuit breakers must be restored to their normal condition.

Safety Do's and Don'ts

DO:

- **Do** perform your tasks carefully, without undue haste.
- **Do** provide a fire extinguisher (rated ABC).
- **Do** provide a First Aid kit (for bumps and abrasions). Obtain medical attention.
- **Do** use the correct tools for the job you are doing.
- **Do** make sure that all fasteners are secure.

Safety Precautions

- **Do** use extreme care while making adjustments on the generator set while it is running.
- **Do** keep your hands away from moving parts.
- **Do** disconnect the battery before starting work on a generator set.
- **Do** use screwdrivers, pliers, diagonal pliers, etc. with insulated handles.
- **Do** obtain CPR (Cardio Pulmonary Resuscitation) and mouth-to-mouth resuscitation knowledge.
- **Do Practice Safety, The Life You Save May Be Your Own.**

DO NOT

- **Don't** allow inexperienced personnel to work on the generator or electrical equipment.
- **Don't** remove guards or protective devices.
- **Don't** wear loose clothing or jewelry in the vicinity of moving parts. These can get in machinery, with disastrous results. Don't wear jewelry while working on electrical equipment. If your hair is long, wear a head covering. Hair caught in a drill press, fan belt or other moving parts can cause serious injury.
- **Don't** stand on a wet floor while working on electrical equipment. Use rubber insulated mats placed on dry wood platforms.
- **Don't** lunge after a dropped tool. To do so may place you in a position of extreme danger.
- **Don't** commence any operation until you have taken all the necessary steps to ensure that you are in complete safety.

Serial Number Locations

Generator: The generator nameplate is attached to the generator housing. The serial number is stamped on the shell.

Engine: The engine serial number is stamped on the back side of the engine block.

SGCO Units: The unit serial number nameplate is attached to the unit battery box beside the engine compartment.

SG+ Controller: The controller serial number nameplate is on the end of the controller.

Unit Decals

Serial number decals, installation decals and warning decals appear on all Thermo King generator sets. These decals provide information

that may be needed to service or repair the unit. Service technicians should read and follow the instructions on all warning decals.

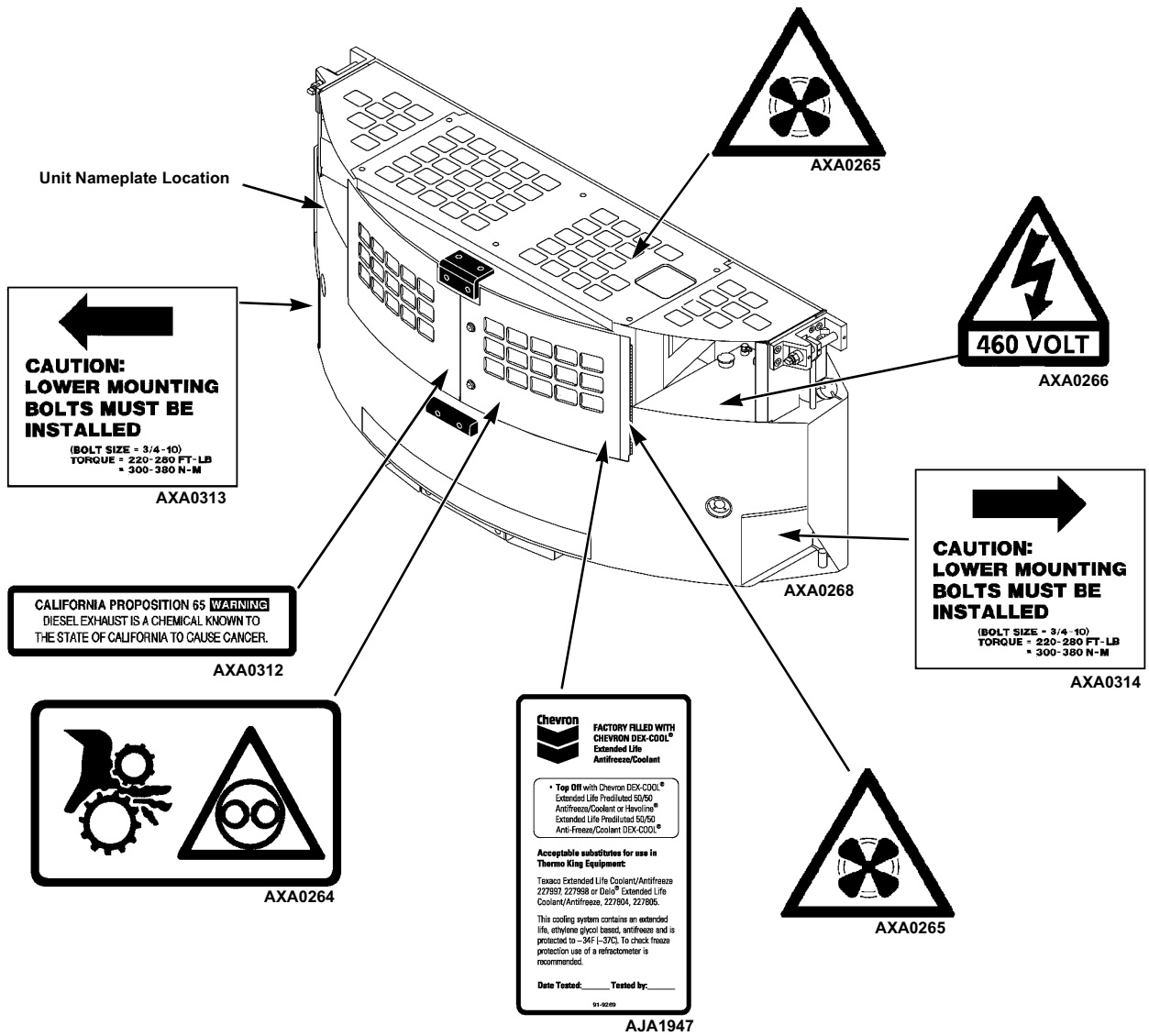

Figure 2: Model SGO 3000 Decals

Service Guide

This table is for Model SGCO 3000.

Pre Trip	Every 250 ¹ Hours	Every 3000 Hours/ Annual	Inspect/Service These Items
			Electrical
•			Perform a controller Pretrip (PTI) check.
•	•	•	Inspect battery terminals and electrolyte level.
		•	Inspect wire harness for damaged wires or connections.
			Engine
•			Check fuel supply and fill.
•	•	•	Check engine oil level and fill as needed.
•	•	•	Check engine coolant level. (CAUTION: Do not remove radiator cap while coolant is hot.)
•	•	•	Inspect belt for condition and proper tension.
•	•	•	Check engine oil pressure hot, on high speed. Minimum 276 kPa, 2.76 bar, 40 psi.
•	•	•	Listen for unusual noises, vibrations, etc.
•	•	•	Inspect/clean fuel transfer pump inlet strainer.
•	•	•	Inspect optional fuel strainer for water or dirt. Remove cover and clean if necessary.
•			Check air cleaner restriction indicator (change filter when indicator reaches 25 in.). Replace air cleaner element at two years if indicator has not reached 25 in.
	•	•	Drain water from fuel tank and check vent. Clean fuel strainer in transfer pump inlet.
	•	•	Check and adjust engine speed. See “Engine Speed Adjustment” on pages 99 and 99.
		•	Change engine oil ² (hot) and oil filter.
		•	Change engine oil (hot) and oil filter. ²
		•	Change fuel filter/water separator. ²
		•	Check condition of engine mounts.
		•	Test fuel injection nozzles at least every 3,000 hours. ³
		—	Change ELC (red) engine coolant every 5 years or 12,000 hours. Maintain antifreeze protection at -34 C (-30 F).
		—	Replace fuel return lines between fuel injection nozzles every 10,000 hours.
			Structural
•	•	•	Visually inspect unit for fluid leaks (coolant and oil).
•	•	•	Visually inspect unit for damaged, loose or broken parts.

¹Inspect/service every 250 operating hours in extreme (dirt yard) operating conditions.

²More frequent intervals may be necessary in extreme operating conditions.

³Based on EPA 40 CFR Part 89.

Specifications

Engine

Diesel Engine Model	TK486V (Tier 2)
Fuel Type	No. 2 Diesel fuel under normal conditions No. 1 Diesel fuel is acceptable cold weather fuel
Oil Capacity Crankcase and Oil Filter:	12.3 litre (13 qt) Fill to full mark on dipstick
Oil Type: Classification:	Multi-grade Petroleum Oil (Standard) Synthetic Oil (Optional) after first 500 hours API Type CI-4 or better ACEA Type E3 or better
Oil Viscosity: Below -30 C (-22 F): -30 C to +50 C (-22 F to +122 F): -25 C to +30 C (-13 F to +86 F): -25 C to +40 C (-13 F to +104 F): -15 C to +40 C (+5 F to +104 F): -10 C to +50 C (+14 F to +122 F):	SAE 0W-30 (Synthetic) SAE 5W-40 (Synthetic) SAE 10W-30 SAE 10W-40 SAE 15W-40 SAE 15W-40 (Synthetic)
Engine Oil Pressure	120 to 320 kPa (1.2 to 3.2 bar) (18 to 47psi)
Engine RPM: No Load:	1890 ± 10 RPM (High Speed) 1560 ± 5 RPM (Low Speed EcoPower Option only)
Valve Clearance	0.15 to 0.25 mm (0.006 to 0.010 in.)
Valve Setting Temperature	21 C (70 F) (Room Temperature)
Low Oil Pressure Switch (Normally Closed)	117 ± 21 kPa (1.17 ± 0.21 bar) (17 ± 3 psi)
High Coolant Temperature Switch*	Sensor*
Engine Thermostat	71 C (160 F)
Coolant System Capacity	9.5 liter (10 qt) with overflow tank
Engine Coolant Type	Texaco ELC (Extended Life Coolant) or equivalent: ELC red coolant, 50/50 antifreeze and water mixture, not to exceed 60/40
Radiator Cap Pressure	90 kPa (0.90 bar) (13 psi)
Fan/Water Pump Belt Tension New or Field Reset:	15 to 35 tension number on belt tension gauge, TK P/N 204-427; or 19 to 25 mm (0.75 to 1.0 in.) deflection with 3 to 4 Kg (6 to 9 lb) of force

* SG+ controller uses a sensor to provide engine high coolant temperature protection.

Generator

Type	460/230 Vac, 3 Phase, 60 Hz
Output Power	15 kw
Kilovolt-Amperes	18.75 kVA
RPM	1800 RPM

Electrical Control System

Controls	SG+ microprocessor controller
Voltage	12.5 Vdc (nominal)
Battery	12 volts, group C31, 925/950 Cold Cranking Amps at -18 C (0 F)
Fuse SI1	30 Amp
Fuse SI2	30 Amp
Fuse SI3	10 Amp

Electrical Components

<i>NOTE: Disconnect components from unit circuit to check resistance.</i>		
	Current Draw (Amperes) at 12.5 Vdc	Resistance (Ohms)
Air Heater	89	0.14
Fuel Solenoid:		
Pull-in	35 to 45	0.2 to 0.3
Hold-in	0.5 to 1.0	24 to 29
Speed Solenoid (EcoPower Option only)	2.9	4.3
Starter Motor	400 (cranking) 140 (bench test)	

Controller Default Settings

Setting – Menu Location	Default Setting
Tank Size – Commands/System Setup	125
Date/Time – Commands/System Setup	Software Date
ID Number – Commands/System Setup	00000000
C/F Mode – Misc. Functions	F
LOP (Low Oil Pressure) Restart – Configuration	Off
DEL (Delayed) Coldstart – Configuration	On
HM1 (Hour Meter 1) Threshold – Configuration	0
HM2 (Hour Meter 2) Threshold – Configuration	0
ENG (Engine) Off Hours – Configuration	0
Factory Reset – Configuration	Off
APU Connected – Configuration	Off
Output Voltage – Configuration	460
Fuel Sensor – Configuration	Off
Fuel Level – Configuration	0
Crank Restarts – Configuration	3
Telematic – Configuration	Off

NOTE: The controller returns the Date/Time to the default setting when the battery is disconnected.

Physical Specifications

Weight (net): SGCO 3000

818 Kg (1804 lbs) including oil, coolant, battery and 473 liter (125 gal.) fuel tank (excluding fuel)

Unit Dimensions:

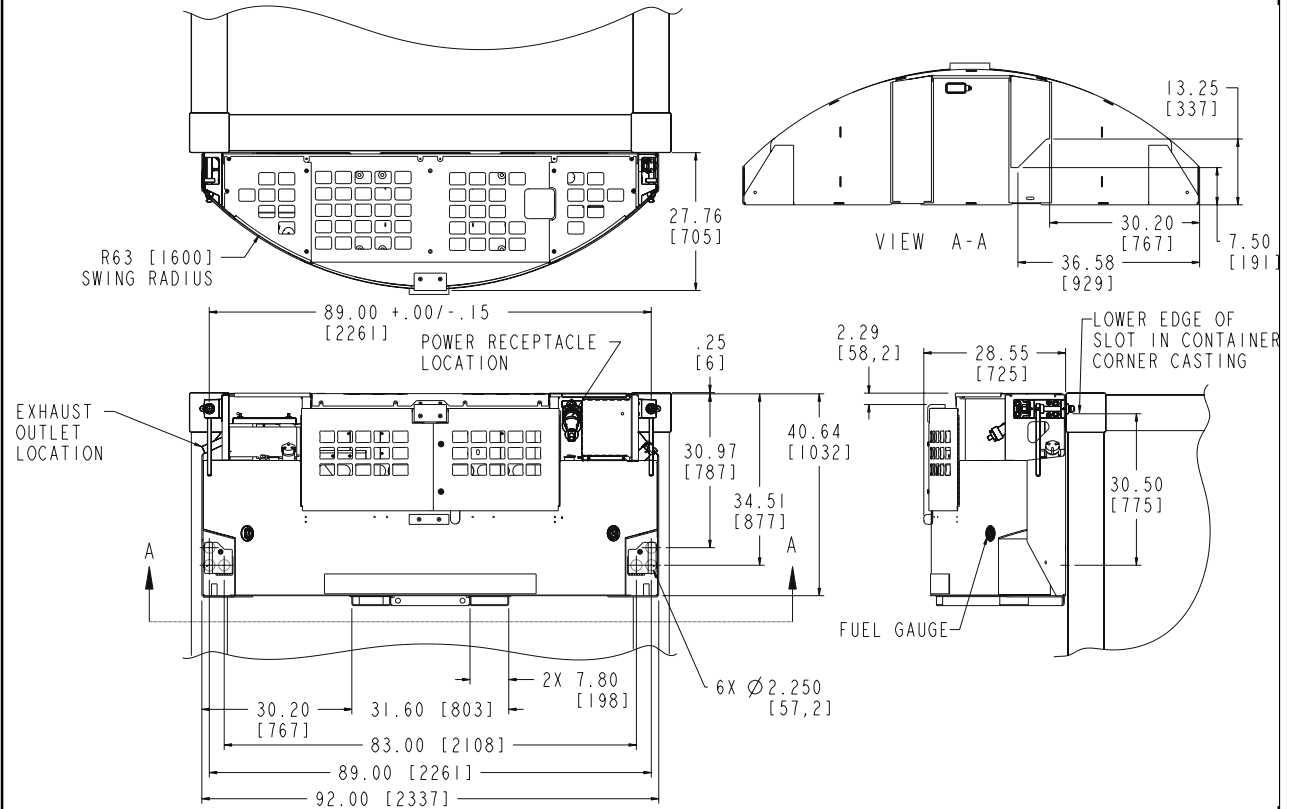

AXA0271

Metric Hardware Torque Charts

Bolt Type and Class*	Bolt Size			
	M6	M8	M10	M12
	N.m (Ft.-lb.)	N.m (Ft.-lb.)	N.m (Ft.-lb.)	N.m (Ft.-lb.)
HH – CL 5.8	6-9 (4-7)	12-16 (9-12)	27-34 (20-25)	48-61 (35-40)
HH – CL 8.8	10-13 (7-10)	20-27 (15-20)	41-47 (30-35)	75-88 (55-65)
HH – CL 10.9	14-17 (10-13)	27-34 (20-25)	54-68 (40-50)	102-122 (75-90)
HH – CL 12.9	17-21 (12-16)	41-47 (30-35)	68-81 (50-60)	122-149 (90-110)
HH – SS (2)	10-13 (7-10)	20-27 (15-20)	41-47 (30-35)	75-88 (55-65)

Bolt Type and Class*	Bolt Size			
	M14	M16	M18	M22
	N.m (Ft.-lb.)	N.m (Ft.-lb.)	N.m (Ft.-lb.)	N.m (Ft.-lb.)
HH – CL 5.8	75-88 (55-65)	115-135 (85-100)	177-216 (130-160)	339-406 (250-300)
HH – CL 8.8	115-135 (85-100)	177-216 (130-160)	271-339 (200-250)	475-610 (350-450)
HH – CL 10.9	136-176 (100-130)	224-298 (180-220)	393-474 (290-350)	678-813 (500-600)
HH – CL 12.9	177-216 (130-160)	285-352 (210-260)	448-542 (330-400)	881-1016 (650-750)
HH – SS (2)	115-135 (85-100)	177-216 (130-160)	271-339 (200-250)	475-610 (350-450)

*HH = Hex Head, CL = Class.

Unit Description, Features & Options

General Description

Thermo King clip-on generator sets are self-contained fully-automatic, diesel powered units. The generator sets supply 230 or 460 Vac electrical power for container refrigeration units. Enclosed within the unit frame are the engine, dual voltage alternator, generator battery compartment, battery charging regulator and control panel.



CAUTION: DO NOT attempt to operate or maintain the generator until you have completely familiarized yourself with the equipment.

An exclusive TK486V (EPA Tier 2) direct injection diesel engine drives a brushless generator to produce 15 KW of output power at 49 C (120 F) ambient temperature. A weatherproof box fastened inside the unit contains the unit controls.

Each unit features a welded, heavy-gauge steel frame with special sea-going finish; non-corrosive fittings, all stainless steel external hardware, copper tube aluminum fin radiator, and poly-vinyl coating on the engine and generator.

Fuel tanks are provided as an integral part of each unit. Fuel capacities are: 473 liter (125 gal.) on SGCO clip-on models.

The alternator is a brushless, rotating field ac generator. A rectified exciter armature output provides dc power for the field. The exciter field obtains its power from the full wave rectified output of the main generator. The alternator supplies 230 or 460 Vac, 3 phase, 4 wire, 60 Hz power at 1800 RPM.

This equipment develops normal output voltages (below 600 volts) whenever the engine is running. All output voltages normally reach 460 volts. Under malfunction conditions, 575 volts may be produced. Any electric potential more than 50 volts is hazardous. Exercise caution and discretion in the operation and maintenance of the equipment.

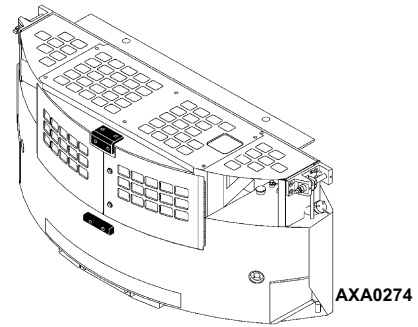

Figure 3: SGCO 3000 Clip On Generator

EMI 3000 Package

These units are equipped with an EMI 3000 Extended Maintenance Interval package. The EMI 3000 package will result in lower total unit life cycle cost, because maintenance intervals have an important impact on unit operating costs.

The EMI 3000 package includes:

- 5 Year or 12,000 Hour Extended Life Coolant (ELC)
- EMI 3000 Dual Element Oil Filter, P/N 11-9182 (identified by black and gold colors)
- EMI 3000 API Rating CI-4 Mineral Oil
- EMI 3000 Fuel Filter, P/N 11-9342 (identified by black and gold colors)

EMI 3000 equipped units are identified by a “ELC” decal tag on the coolant expansion tank, and gold and black colored oil and fuel filters. The EMI 3000 package allows standard genset maintenance intervals to be extended to 3000 hours. However, please note that units equipped with the EMI 3000 package still require regular inspection in accordance with Thermo King pretrip inspection and maintenance recommendations (see the Service Guide chapter in this manual).

SG+ Microprocessor Controller

The SG+ Microprocessor controller controls and monitors unit operation, records system faults and performs an automatic pre-trip check. The controller monitors all unit protection shutdown functions and the exciter system. The controller shuts down unit operation due to low engine oil pressure, low engine oil level, high coolant temperature, fuel relay feedback failure, or alternator overload. The module also delays excitation power supply for 15 seconds after unit start-up or until the engine water temperature reaches 32 C (90 F).

The SG+ Microprocessor controller is designed with the capability to have the software flash loaded.



Figure 4: SG+ Controller Display

Unit Instruments

INDICATOR LEDs.

- a. **POWER LED:** A green Power LED lights up while the Unit On/Off Switch is in the ON position. It is located on the controller display.
- b. **ALARM LED:** A red Alarm LED illuminates when a shutdown condition has occurred. It is located on the controller display.

FUEL GAUGE. A gauge mounted in the fuel tank indicates the level of diesel fuel in the tank.

Unit Protection Devices



WARNING: *the unit may start at any time without warning when the unit On/Off switch is in the On position.*

Units equipped with a SG+ controller feature a Delayed Restart mode. The controller will make up to three (3) attempts every 20 minutes to restart the unit after a Delay Alarm has occurred. The Delayed Restart mode continues until the unit has been successfully restarted, or until a Shutdown Alarm is generated. Protection shutdown devices that cause an Delayed Restart shutdown condition include:

- *Low Oil Pressure*
- *Low Oil Level*
- *High Water Temperature*

Low Oil Pressure Switch: Engine oil pressure should rise immediately on starting. The controller will stop the engine if oil pressure drops below 117 ± 21 kPa, (1.17 ± 0.21 bar), (17 ± 3 psig) for more than 30 seconds, and the oil level drops below 8 qt (7.6 litres) (Also see oil level sensor below). The controller then records an alarm.

Oil Level Sensor: An oil level switch closes if the oil level drops below 8 qts. (7.6 liters) and the oil pressure drops below 117 ± 21 kPa (Also see low oil pressure switch above). The controller will stop the engine if the switch stays closed for more than 30 seconds. The controller then records an alarm.

Water Temperature Sensor: The controller will stop the engine if the engine coolant temperature rises to 107 C (225 F) for more than 30 seconds. The controller also records an alarm. The unit will restart when the coolant temperature drops to 88 C (190 F).

Dual Voltage Option

A power cable and receptacle wired for 230 Vac or 460 Vac is supplied as standard equipment with each generator.

EcoPower Option

EcoPower™ is an option designed to save fuel. A speed solenoid is mounted on the engine and controlled by the controller. The controller monitors the load from the refrigeration unit and determines if the engine should run in high speed (1890 ± 10 RPM), or low speed (1560 ± 5 RPM). The output frequency is 60 Hz in high speed and 50 hz in low speed. The engine runs in high speed for at least one hour when it is started, and whenever it shifts from low speed to high speed. Units equipped with the EcoPower option have the following decal.

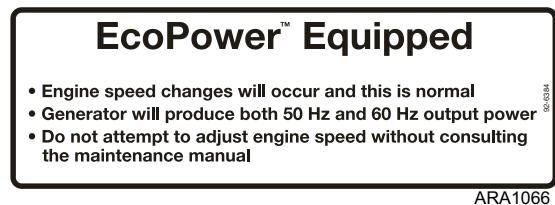

Figure 5: EcoPower Decal

Fuel Level Sensor Option

The fuel level sensor option allows the controller to log fuel events (see “Fuel Events” on page 74). Units equipped with the fuel level sensor option must have the Fuel Sensor turned on in the Configuration Menu (see “Configuration Menu” on page 69), and the fuel tank size set in the System Setup submenu (“System Setup” on page 62).

Additional Options

Header pin mounting (SGCO clip-on models only).

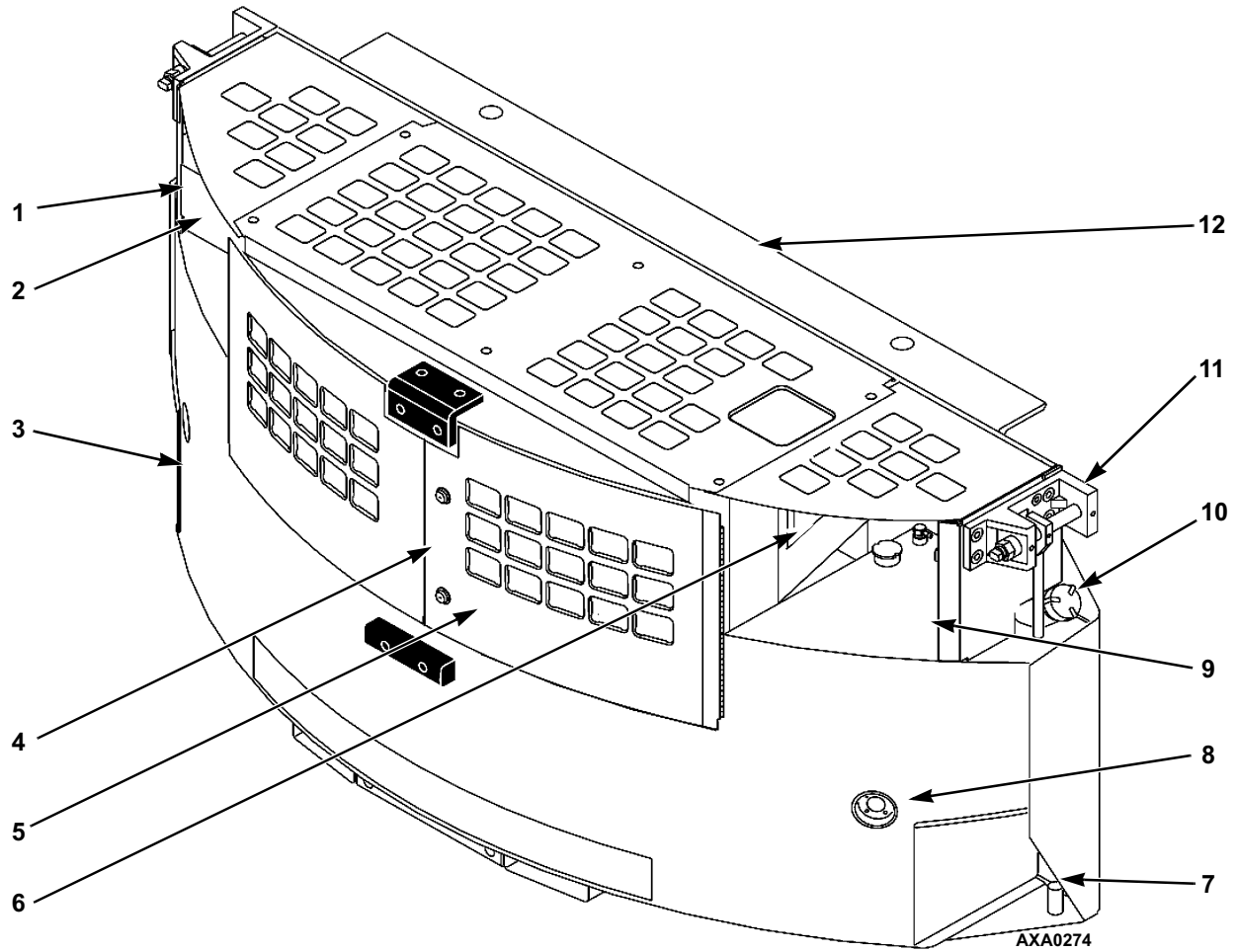

1.	Battery	7.	Lower Mounting Screw and Washer (each side)
2.	Unit Nameplate Location	8.	Fuel Gauge (each side)
3.	Fuel Tank	9.	Control Box Location
4.	Alternator and Engine Compartment Access Doors	10.	Fuel Tank Fill Neck and Cap (each side)
5.	Coolant Expansion Tank Location	11.	Upper Unit Mounting Clamps (Corner Clamp Equipped Units Only)
6.	460 or 230 Vac Power Receptacle Location	12.	Header Pin Mounting Flange (Header Pin Equipped Units Only)

Figure 6: SGC0 3000 — Unit Front View

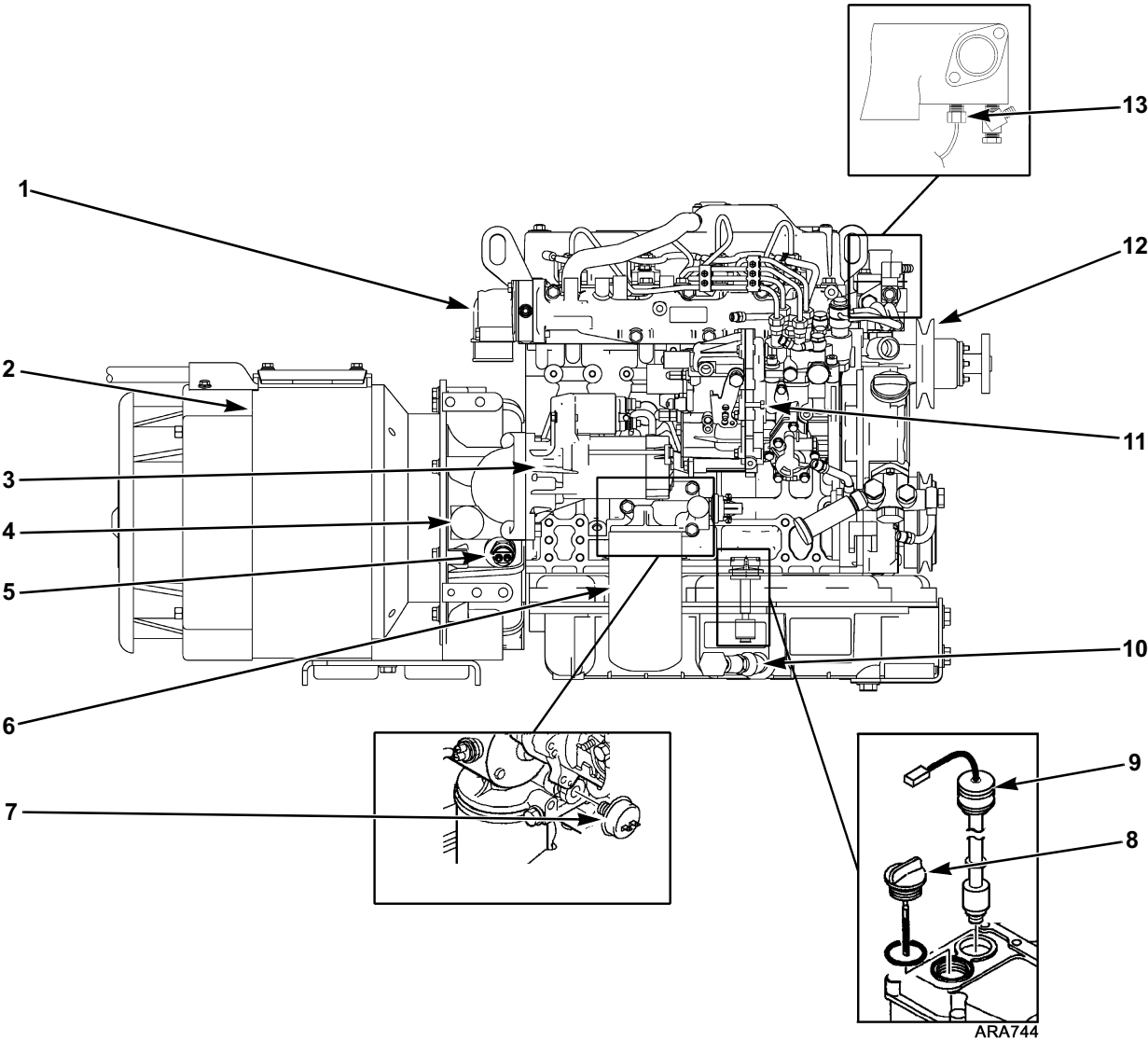

1.	Air Inlet Adapter	8.	Oil Fill and Dipstick
2.	Alternator	9.	Oil Level Sensor
3.	Starter	10.	Oil Drain
4.	Timing Mark Location	11.	Engine Speed Adjustment Screw
5.	Flywheel Sensor	12.	Water Pump Pulley
6.	Oil Filter	13.	Water Temperature Sensor
7.	Low Oil Pressure Switch		

Figure 7: Powerpack (All Models) — Unit Front View

Controller Description

SG+ Controller Description

The SG+ controller is a two-piece, self contained microprocessor for diesel generator sets. The SG+ display is mounted on the control box cover. The SG+ microprocessor is mounted inside the control box (see Figure 9 on page 34). Two external relays, the Start Relay and the Preheat Relay, are also mounted inside the control box near the microprocessor.

This system automatically controls generator operation by providing:

- Automatic unit preheat and engine startup during initial startup or delayed restart
- Variable air heater preheat time
- Automatic Pretrip Test capability
- Delayed alternator excitation for 15 seconds or until engine coolant temperature increases to 32 C (90 F)
- Unit shutdown protection for the engine and alternator. The controller stops the unit due to low engine oil pressure, low engine oil level, high coolant temperature, fuel relay feedback failure, or alternator overload.
- Automatic unit restart 20 minutes after unit shutdown due to an unknown condition, high engine water temperature, engine failure to start, fuel relay feedback failure, check fuel alarm, or alternator overload (also low engine oil pressure if enabled). It will attempt three (3) restarts and then stop.



ARA9890

Figure 8: SG+ Controller Display

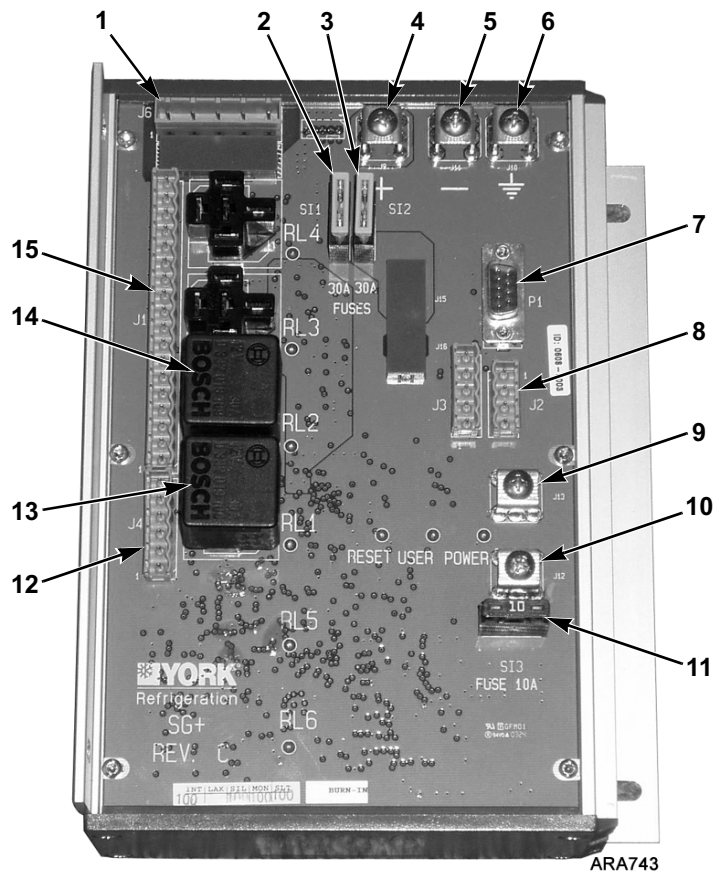

1.	J6 Connector – To AC Circuits
2.	Fuse SI1 – 30 Amp Protects 8D and 8DP Circuits
3.	Fuse SI2 – 30 Amp Protects Battery Charger Output Circuit
4.	2A Circuit Connection
5.	CH Circuit Connection
6.	GND Circuit Connection
7.	Serial Port – For Flash Loading Software
8.	J2 Connector – To SG+ Controller Display
9.	2C Circuit Connection
10.	8 Circuit Connection
11.	Fuse SI3 – 10 Amp Protects Microprocessor Power Input Circuit
12.	J4 Connector – To External Relay Circuits
13.	RL1 – Fuel Pull Relay
14.	RL2 – Fuel Hold Relay
15.	J1 Connector – To Sensor and Fuel Solenoid Circuits

Figure 9: SG+ Microprocessor

Controller Overview

Display: A vacuum lucent display on the front panel shows operating information including output voltage, current test state during a Pretrip test and the controller menu. Normally it shows the Output Voltage (this is called the Standard Display). It will be blank when the unit On/Off switch is OFF.

Keypad: Contains the following six keys.

Escape Key: Press this key to escape a new setting or jump to the parent menu.

Up Key: Press this key to scroll UP through the menu display, or increase the value of a setting.

Down Key: Press this key to scroll DOWN through the menu display, or decrease the value of a setting.

Enter Key: Press this key to enter or execute controller menu tasks or commands.

Alarm Key: Press this key to go directly to the Alarm List Menu and view the alarm information in the display.

Language Key: Press this key to change the language used on the display. English and Spanish are the languages that are currently available.

Alarm LED: Flashes when the controller has detected an alarm condition. It is off when there are no alarms.

Power LED: Lights up while the Unit On/Off Switch is in the ON position. It is off when the Unit On/Off Switch is in the OFF position.

Unit On/Off Switch: In the ON position, the electrical control system energizes for unit operation. In the OFF position, the electrical control system including the fuel solenoid de-energizes to stop the engine. The unit will not operate.

Download Port: Is used to download the event logger and flash load new software.

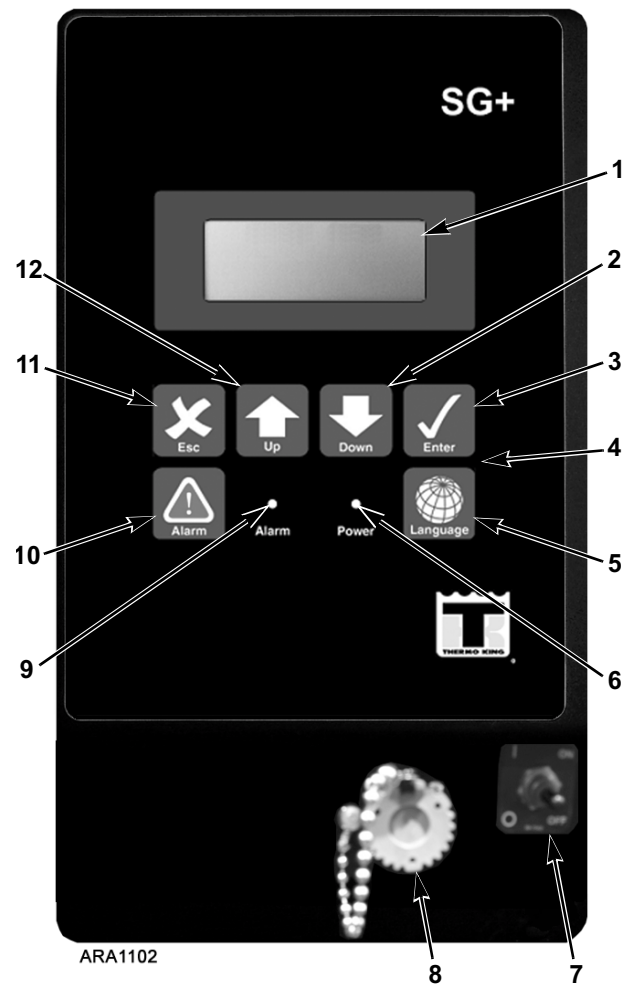

1.	Display
2.	Down Key
3.	Enter Key
4.	Keypad
5.	Language Key
6.	Power LED
7.	Unit On/Off Switch
8.	Download Port
9.	Alarm LED
10.	Alarm Key
11.	Escape Key
12.	Up Key

Figure 10: Control Box Cover

Miscellaneous Features

- Internal self-checking/diagnostic capability
- Pretrip test capability (see “PTI” on page 59)
- Hourmeter: The controller has a built-in run hourmeter that can be accessed through the Timers/Counters Submenu under the Misc. Functions Menu.
- The application software version is displayed by selecting the Program Version Submenu under the Misc. Functions Menu.
- Display menus: The SG+ controller contains extensive display menus that can be navigated via the keypad. The display menus are organized into seven Main Menus: Data Menu, Alarm List Menu, Warning List Menu, Commands Menu, Misc. Functions Menu, Configuration Menu, and Event Log Menu.
- Microprocessor Inputs:
 - Engine Oil Pressure
 - Alternator Voltage
 - Battery Voltage
 - Water (Engine Coolant) Temperature
 - Air Filter Switch
 - Coolant Level Sensor
 - Engine Oil Pressure Switch
 - Engine Oil Level Sensor
 - Air Heater (Preheat) Feedback
 - Fuel Pull Relay Feedback
 - Fuel Hold Relay Feedback
 - Excitation Feedback
 - Flywheel Sensor
- Microprocessor Outputs:
 - Start Relay
 - Preheat Relay
 - Fuel Pull Relay
 - Fuel Hold Relay
 - Speed Solenoid Relay (EcoPower Option only)
 - On Light
 - Alarm Light.

Navigating the Controller Menus

Controller Display Menus

The SG+ controller contains extensive display menus that can be navigated via the keypad. The display menus are organized into the following menus (or groups) in the Main Menu:

- Data Menu
- Alarm List Menu
- Message List Menu
- Commands Menu
- Misc. Functions Menu
- Configuration Menu
- Event Log Menu

The display also has some displays in addition to the Main Menu.

- Standard Display
- Pause Mode Display

Each menu listed above will be described later in this chapter.

An overview of the menu structure is shown in Figure 12 on page 38.

A complete listing of the controller menus is located on the 11 x 17 in. fold outs in the Diagrams section in the back of the manual (see last two pages in the manual). It is designed to be folded out so you can continuously view it as you are learning how to navigate the SG+ Controller Menus. It is recommended to fold this flow diagram out and leave it folded out until you become familiar with the controller menus.



Down Key: Press the **DOWN** key each time you want to scroll down to view another item in a menu (or submenu), or decrease the value of a setting.



Enter Key: Press the **ENTER** key each time you want to enter or execute controller menu tasks or commands.



Alarm Key: Press the **ALARM** key to go directly to the Alarm List Menu and view the alarm information in the display.



Language Key: Press the **LANGUAGE** key to change the language used on the display.

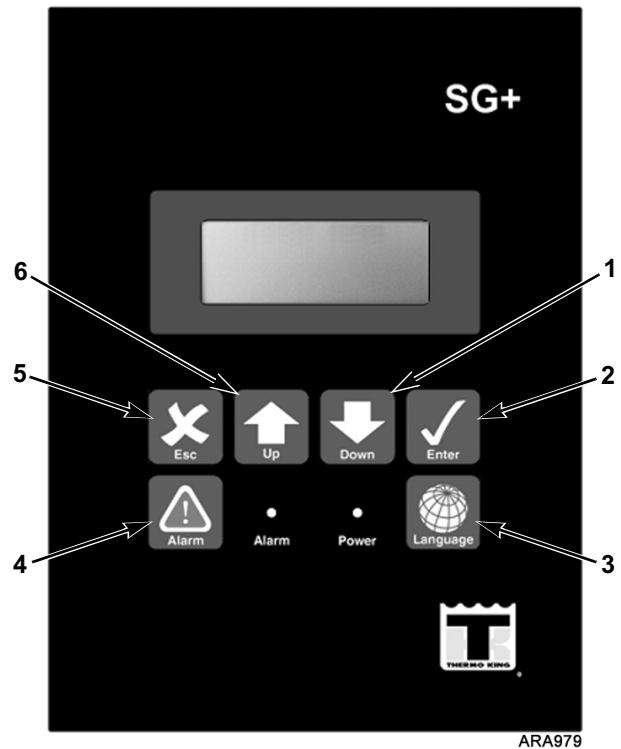

1.	Down Key
2.	Enter Key
3.	Language Key
4.	Alarm Key
5.	Escape Key
6.	Up Key

Figure 11: Controller Display

Navigating Controller Menus

Moving through the menus and their submenus and entering commands requires the use of the following keys:



Escape Key: Press the **ESCAPE** key to escape a new setting or jump to the parent menu.



Up Key: Press the **UP** key each time you want to scroll up to view another item in a menu (or submenu), or increase the value of a setting.

Menu Overview

Press the **UP** or **DOWN** keys to scroll through the Main Menu or a Submenu. Press the **ENTER** key to enter a Submenu or Event. Press the **ESCAPE** key to return to the parent menu.

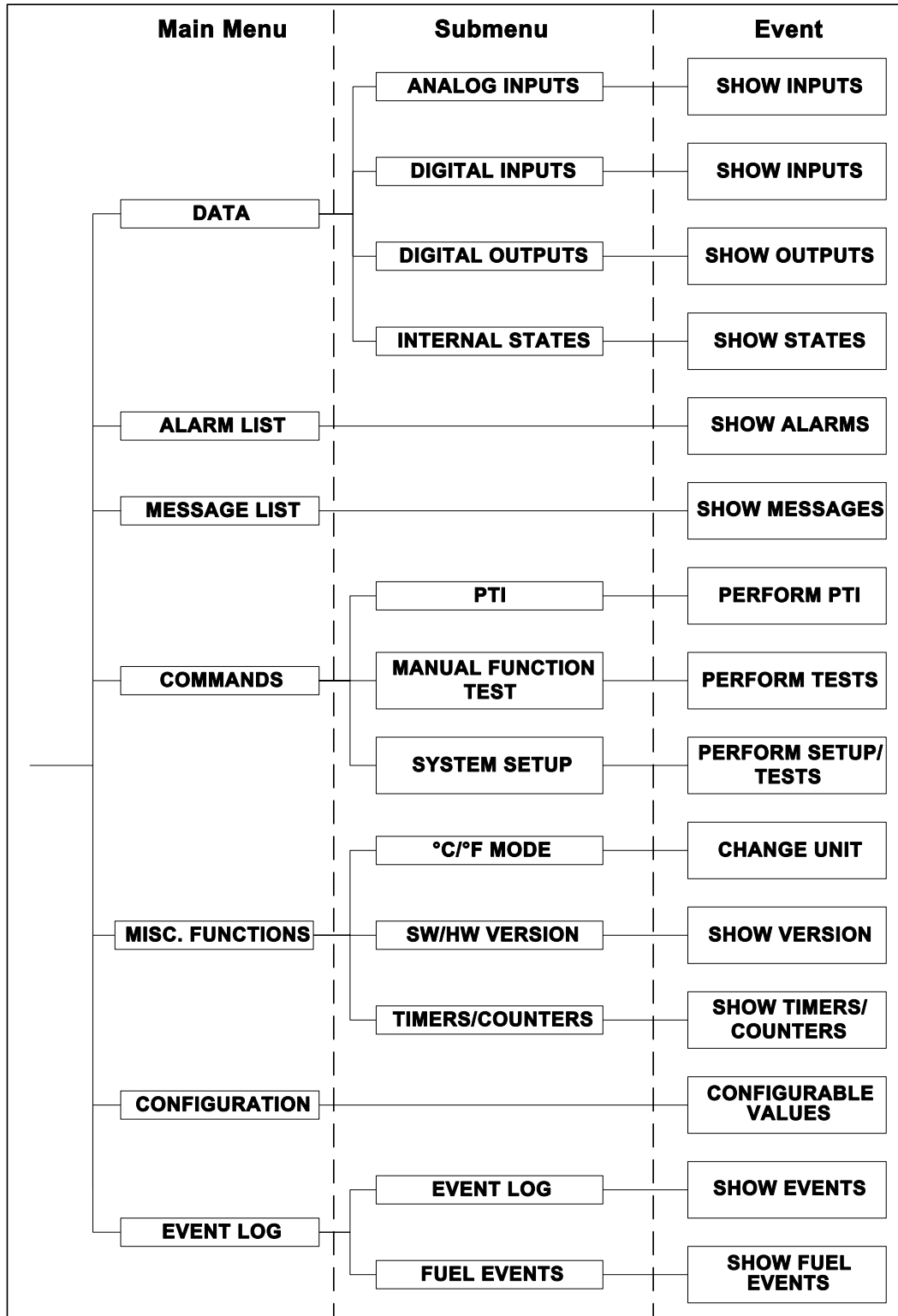

ARA1103

Figure 12: Menu Structure

Data Menu

The Data Menu contains the following submenus. See “Data Menu” on page 46 for more information.

- Analog Inputs, which displays unit operating information from analog inputs such as oil pressure and output voltage. See “Analog Inputs” on page 47 for more information.
- Digital Inputs, which displays unit operating information from digital inputs such as the oil level switch and feedback from the fuel solenoids. See “Digital Inputs” on page 48 for more information.
- Digital Outputs, which displays unit operating information from digital outputs such as the start relay and the preheat relay. See “Digital Outputs” on page 49 for more information.
- Internal States, which displays unit operating information such as the status of components, if the unit is running, and the engine RPM. See “Internal States” on page 50 for more information.

Alarm List Menu

The Alarm List Menu shows a list of the alarms recorded in the controller memory. See “Alarm List Menu” on page 51 for more information.

Message List Menu

The Message List Menu shows a list of the messages recorded in the controller memory. See “Message List Menu” on page 54 for more information.

Commands Menu

The Commands Menu contains the following submenus:

- PTI, which is the Pretrip Inspection Test. The PTI is a functional test of the unit. See “PTI” on page 59 for more information.
- Manual Function Test, which is used to test some components such as the display and relays. See “Manual Function Test” on page 60 for more information.

- System Setup, which is used to check the engine speed, energize and de-energize the Speed Solenoid, set the unit fuel tank size, set the date and time, and set an ID number to identify the unit. See “System Setup” on page 62 for more information.

Misc. Functions Menu

The Misc. Functions Menu contains the following submenus:

- C/F Mode, which is used to select whether Celsius or Fahrenheit units are used to display temperature readings. See “C/F Mode” on page 66 for more information.
- SW/HW Version, which displays information about the controller software and hardware. See “SW/HW Version” on page 67 for more information.
- Timers/Counters, which displays information about the hourmeters and restart counters. See “Timers/Counters” on page 68 for more information.

Configuration Menu

The Configuration Menu is used to configure some of the controller functions such as low oil pressure restart and hourmeter thresholds. See “Configuration Menu” on page 69 for more information.

Event Log Menu

The Event Log Menu contains the following submenus:

- Event Log, which shows a list of events, warnings, and alarms recorded in the controller memory. See “Event Log” on page 74 for more information.
- Fuel Events, which shows a list of fuel events recorded in the controller memory. See “Fuel Events” on page 74 for more information.

Standard Display

The Standard Display shows the output voltage. It appears approximately one minute after the last key is pressed while the unit is running. The Standard Display floats within the display to prevent burn in.

Press the **ENTER** key or the **ESCAPE** key at the Standard Display to enter the Main Menu.

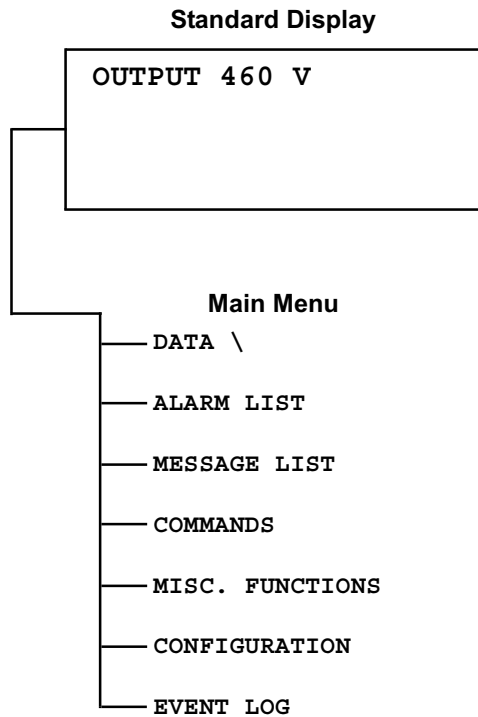

Figure 13: Standard Display and Main Menu

Pause Mode Displays



WARNING: *The AC alternator output or engine may start at any time without notice when the unit is in a PAUSE mode.*

A Pause mode display appears when normal unit operation has been interrupted because of a warning or alarm. The display will show the cause and controller action. For example, the following display appears if the engine fails to start.

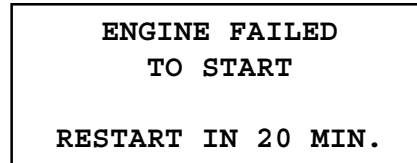

Figure 14: Typical Pause Mode Display

Network Down Display

The Network Down display indicates there is no communication between the SG+ controller and the display. This is typically caused by a defective SG+ controller, a defective display, a defective cable, or a bad connection on the cable between the SG+ controller and the display.

The Network Down display also appears when software is be flash loaded into the controller.

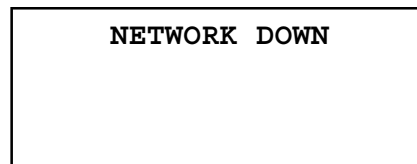

Figure 15: Network Down Display

Operating Instructions

Pretrip Inspection

The pretrip inspection is an important part of the preventive maintenance program. It's designed to head off operating problems and breakdowns before they happen. The Pretrip Inspection is not a substitute for a regularly scheduled maintenance.

Visual Inspection

The following inspections should be made before loading the container or trailer:

Fuel: The diesel fuel supply must be sufficient to guarantee engine operation to the next check point.

Engine Oil: Engine oil level should be at the FULL mark. Never overfill. The dipstick is attached to the filler cap.

Coolant: Engine coolant must be above the ADD mark with antifreeze protection of -34 C (-30 F). Check and add coolant in the expansion tank.



WARNING: DO NOT remove the radiator cap from the radiator fill neck when the engine coolant is hot.



CAUTION: With both *Extended Life Coolant (EMI 3000)* and *Conventional Coolant (non-EMI 3000)* equipped units operating in the field, there are several important rules to remember:

- *Extended Life Coolant (ELC)* is **RED** in color while *conventional coolant* is **GREEN** or **BLUE-GREEN**.
- *Do not add GREEN or BLUE-GREEN, conventional coolant to cooling systems using RED, Extended Life Coolant, except in an emergency. If conventional coolant is added to Extended Life Coolant, the coolant must be changed after 2 years instead of 5 years.*

Battery: Terminals must be clean. Electrolyte should be at the full mark.

Belt: The water pump belt must be in good condition and adjusted to proper tension.

Electrical: Electrical connections should be securely fastened. Check wires and terminals for corrosion, cracks or moisture. Repair or replace if necessary.

Structural: Visually inspect the unit for leaks, loose or broken parts and other damage. The radiator coil should be clean and free of debris. Clean if necessary. Use an air or water spray jet directed against the coil from the air discharge side.



CAUTION: Air or water spray jet pressure should not be high enough to damage (bend) coil fins.

Mounting Bolts: Check the mounting bolts on the unit and engine. Tighten if necessary.

Starting the Unit

Generator sets are designed to provide power for a refrigeration unit. Before starting the generator set, make sure the refrigeration unit power cord is connected to the generator set electric power receptacle. To operate the refrigeration unit on standby power, disconnect the power cord from the generator set and plug it into the proper power supply.



WARNING: *With the unit On/Off switch in the “ON” position, the unit may start at any time without prior warning.*

1. Turn unit **ON/OFF** switch to On.
2. A series of displays called the Start Sequence appears on the display as follows:
 - a. YORK HMI
REV 1.0
 - b. YORK HMI
SUM: XXX
 - c. MAIN MENU
DATA
DELAY 11 (or 10, 09, 08, etc. to 01)
The delay screen counts down from 11 to 01 while the controller performs some self checks.
 - d. MAIN MENU
DATA
INIT
The controller energizes the air heater for preheat (if necessary). The preheat buzzer is energized during the preheat period. Preheat time ranges from 5 to 120 seconds, depending on the engine temperature. Preheat may continue until after the engine starts.
 - e. MAIN MENU
DATA
FUEL RELAY ON
The controller energizes the fuel relay.
 - f. MAIN MENU
DATA
ALTERNATOR OFF
The controller verifies that the alternator output is off.
 - g. MAIN MENU
DATA
AIR HEATER ON
This display appears only if the controller determines that the engine coolant temperature is low enough to require that the air heater be energized.
 - h. MAIN MENU
DATA
STARTER
The engine begins cranking. The air heater and pre-heat buzzer may remain energized during the cranking period. The air heater may also remain energized for 30 seconds after the engine starts.
 - i. MAIN MENU
DATA
RPM CHECK
If the engine RPM does not exceed 50 RPM during the first 4 seconds of cranking, or if the engine does not start after 30 seconds of cranking, the cranking cycle terminates.
 - j. MAIN MENU
DATA
SPEED MEAS
This display appears only on units equipped with the EcoPower option while the controller checks the low engine speed. The engine runs in low speed until the engine temperature reaches 32 C (90 F).
 - k. MAIN MENU
DATA
DELAYED OUTPUT
This display appears while the controller delays energizing the alternator output for approximately 15 seconds. If the DEL COLDSTART feature in the Configuration Menu is set to ON, the alternator output remains off until the engine temperature reaches 32 C (90 F).

1. MAIN MENU
DATA
SPEED MEAS
This display appears only on units equipped with the EcoPower option while the controller checks the high engine speed. The engine switches to high speed when the engine temperature reaches 32 C (90 F).
 - m. MAIN MENU
DATA
VOLTAGE:
This display shows the alternator output, indicating the alternator is functioning.
 3. If the engine fails to start, place the unit switch in the **OFF** position. Determine and correct the cause of the starting failure. Then repeat the starting procedure.
- a. Press the **ENTER** key or the **ESCAPE** key to enter the Main Menu, if necessary.
 - b. Press the **UP** or **DOWN** key to scroll up or down through the Main Menu to the Commands Menu.
 - c. Press the **ENTER** key to enter the Commands Menu.
 - d. The PTI submenu will be displayed.
 - e. Press the **ENTER** key to start the PTI.
3. The controller then performs the PTI. Observe the unit for proper operation and functions during the PTI. The display shows which component is being tested, and the test result (PASSED or FAILED).
 - a. The engine stops.
 - b. The controller beeps to test the buzzer.
 - c. A display test is performed. Watch the display to verify it is operating properly.
 - d. The oil level switch is tested.
 - e. The oil pressure switch is tested.
 - f. The coolant temperature sensor is tested.
 - g. The coolant level is tested.
 - h. Test speed solenoid relay, if detected.
 - i. The preheat relay is tested.
 - j. The fuel hold relay is tested.
 - k. The fuel pull relay is tested.
 - l. Test fuel level, if selected.
 - m. The start relay is tested.
 - n. The output voltage is tested.
 - o. The engine starts.
 - p. The display says “PASSED OUTPUT VOLTAGE TEST” if the output voltage is acceptable.
 - q. The oil pressure switch is tested.
 - r. Preheat is tested.
 - s. Test speed solenoid high and low, if detected.



CAUTION: *Never use starting fluid.*

After Start Inspection

After the engine has started:

1. Listen for abnormal noises.
2. Check for any alarms or messages using the Alarm List Menu and the Message List Menu.

NOTE: *The engine must operate for approximately 15 seconds before the exciter circuit and battery charging circuits are energized. When DEL COLDSTART feature in the Configuration Menu is set to ON, the alternator output remains off until the engine temperature increases to 32 C (90 F).*

Functional Inspection

To properly perform a PTI (Pretrip Inspection Test) on units equipped with a SG+ controller, do not apply a load to the alternator.

1. Start the unit (see “Starting the Unit” on page 42).
2. Initiate an automatic PTI.

NOTE: *Correct all existing alarm conditions and clear the alarm codes before performing a PTI.*

NOTE: If a component fails its test, the PTI will stop at that point and display “FAILED - REBOOT”. Correct the problem and repeat the PTI by pressing the ENTER Key.

4. When the PTI is complete, the test ends automatically and the controller display shows “PTI PASSED (or FAILED) - REBOOT”. Turn the On/Off Switch Off and back On to reboot and return the unit to normal operation.
5. If an operating problem occurs during the PTI, view and correct any alarms or messages. Then acknowledge the alarms or messages and repeat the PTI.

NOTE: Acknowledge the alarms or messages ONLY after the alarm codes are documented and problems repaired.

Main Menu

The Main Menu contains the following menus:

- Data Menu
- Alarm List Menu
- Message List Menu
- Commands Menu
- Misc. Functions Menu
- Configuration Menu
- Event Log Menu

To enter the Main Menu complete the following steps:

1. Place the On/Off switch in the “ON” position.
2. Press the **ENTER** key or the **ESCAPE** key to enter the Main Menu, if it is not displayed.
3. The Data Menu is typically the first menu displayed in the Main Menu.
 - Press the **ENTER** key to enter the Data Menu.
 - Press the **Up** or **Down** key to scroll up or down through the Main Menu.

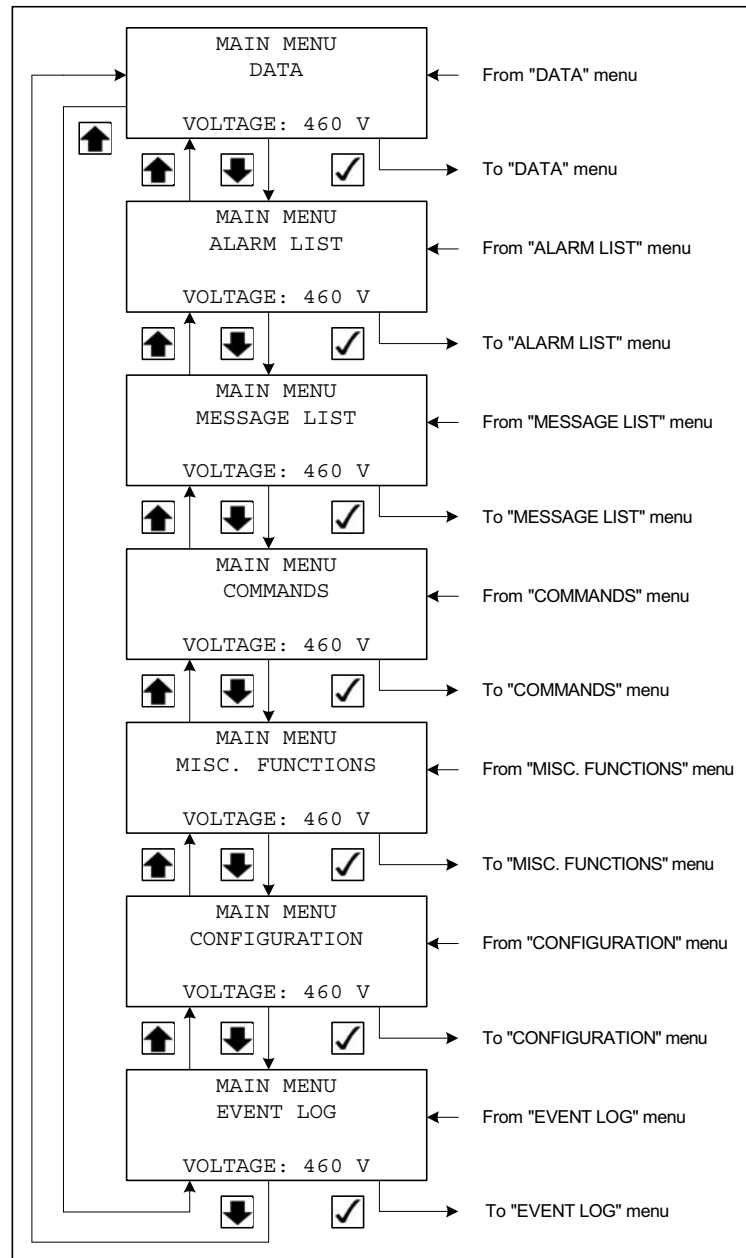

ARA981

Figure 16: Main Menu

Data Menu

NOTE: The Data Menu only displays information, items can NOT be changed.

The Data Menu displays general unit operating information including electrical data, temperatures, etc. It contains the following submenus:

- Analog Inputs
- Digital Inputs
- Digital Outputs
- Internal States

To enter the Data Menu complete the following steps:

1. Place the On/Off switch in the “ON” position.

2. Press the **ENTER** key or the **ESCAPE** key to enter the Main Menu, if necessary.
3. The Data Menu is typically the first menu displayed in the Main Menu.

NOTE: Press the **UP** or **DOWN** key to scroll up or down through the Main Menu to the Data Menu, if necessary.

4. Press the **ENTER** key to enter the Data Menu.
5. The Analog Inputs submenu will be displayed.
 - Press the **ENTER** key to enter Analog Inputs.
 - Press the **UP** or **DOWN** key to scroll up or down through the Data Menu.
 - Press the **ESCAPE** key to return to the Main Menu.

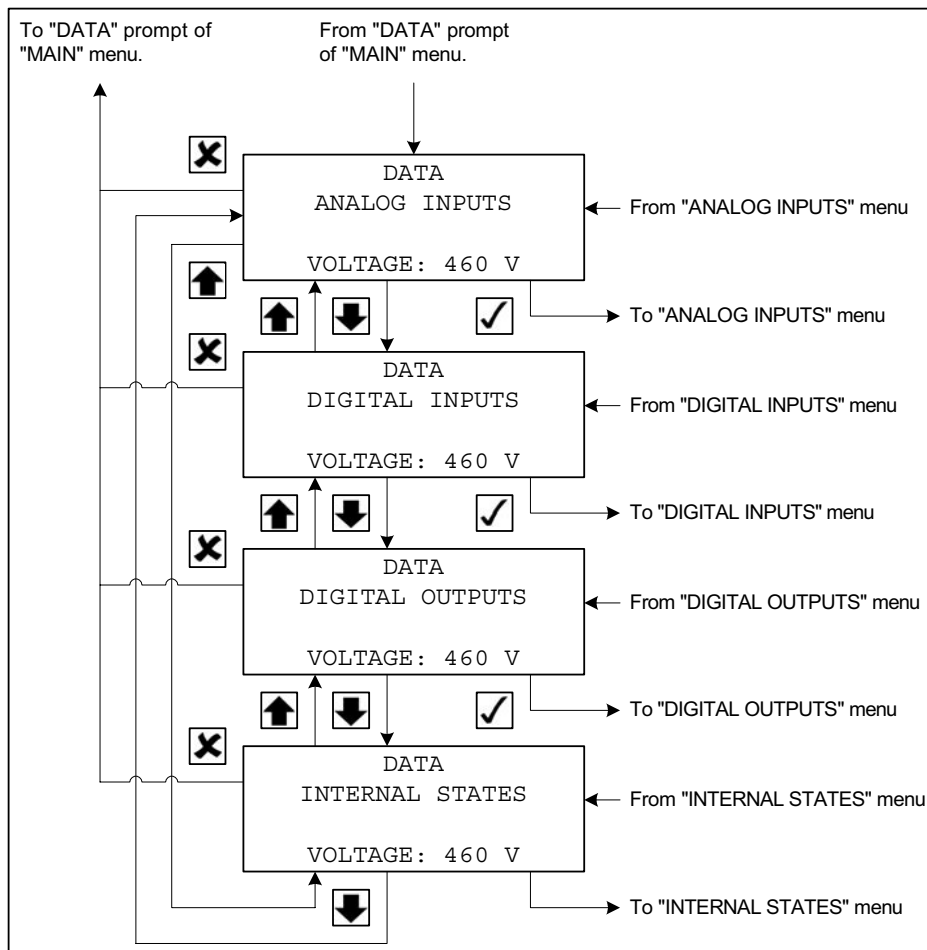

ARA982

Figure 17: Data Menu

Analog Inputs

The Analog Inputs display the following unit operating information:

- Voltage Meas. (AC Output Voltage)
- Field Current (Current on F1)
- Water Temp. (Engine Coolant Temperature)
- Running Freq. (AC Output Frequency)
- Bat. Voltage (Battery Voltage)

To enter the Analog Inputs complete the following steps:

1. Place the On/Off switch in the “ON” position.
2. Press the **ENTER** key or the **ESCAPE** key to enter the Main Menu, if necessary.
3. The Data Menu is typically the first menu displayed in the Main Menu.

NOTE: Press the UP or DOWN key to scroll up or down through the Main Menu to the Data Menu, if necessary.

4. Press the **ENTER** key to enter the Data Menu.
5. The Analog Inputs submenu will be displayed.
6. Press the **ENTER** key to enter the Analog Inputs.
 - Press the **UP** or **DOWN** key to scroll up or down through the Analog Inputs.
 - Press the **ESCAPE** key to return to the Data Menu.

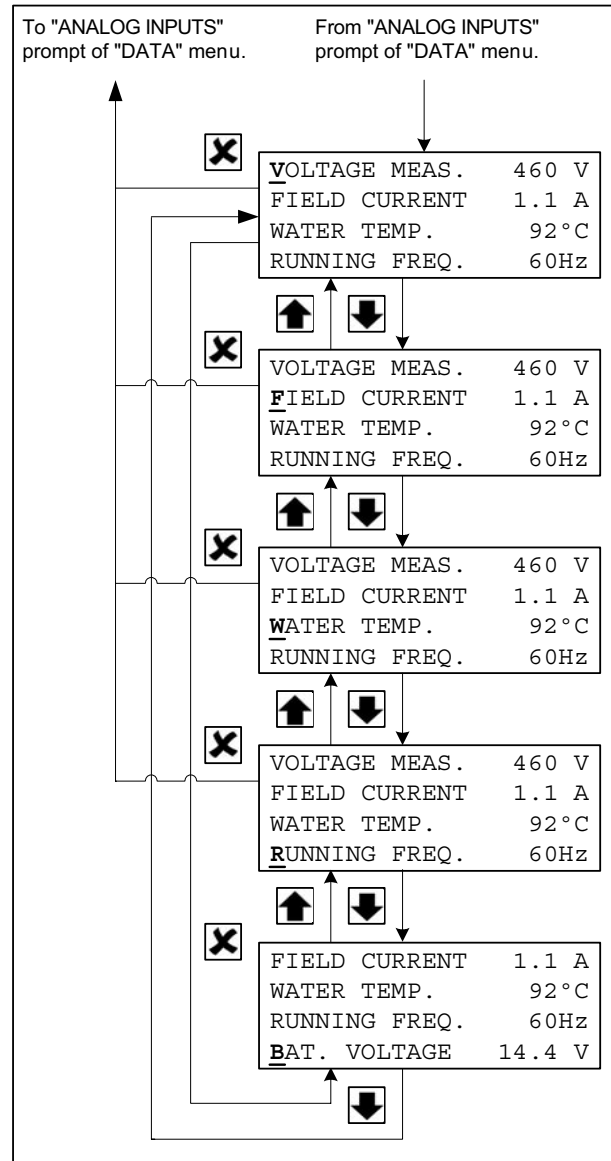

ARA1664

Figure 18: Analog Inputs

Digital Inputs

The Digital Inputs display the status of the following inputs:

- Air Filter Switch
- Coolant Level Low
- Oil Pressure Low
- Oil Level Low
- Spare 1
- Spare 2
- Starter FB (Feedback)
- Air Heater FB (Feedback)
- Fuel Pull FB (Feedback)
- Fuel Hold FB (Feedback)
- Speed Solenoid FB (Feedback)
- Spare 2 FB (Feedback)

To enter the Digital Inputs complete the following steps:

1. Place the On/Off switch in the “ON” position.
2. Press the **ENTER** key or the **ESCAPE** key to enter the Main Menu, if necessary.
3. The Data Menu is typically the first menu displayed in the Main Menu.

NOTE: Press the **UP** or **DOWN** key to scroll up or down through the Main Menu to the Data Menu, if necessary.

4. Press the **ENTER** key to enter the Data Menu.
5. Press the **UP** or **DOWN** key to scroll up or down through the Data Menu to the Digital Inputs submenu.
6. Press the **ENTER** key to enter the Digital Inputs.
 - Press the **UP** or **DOWN** key to scroll up or down through the Digital Inputs.
 - Press the **ESCAPE** key to return to the Data Menu.

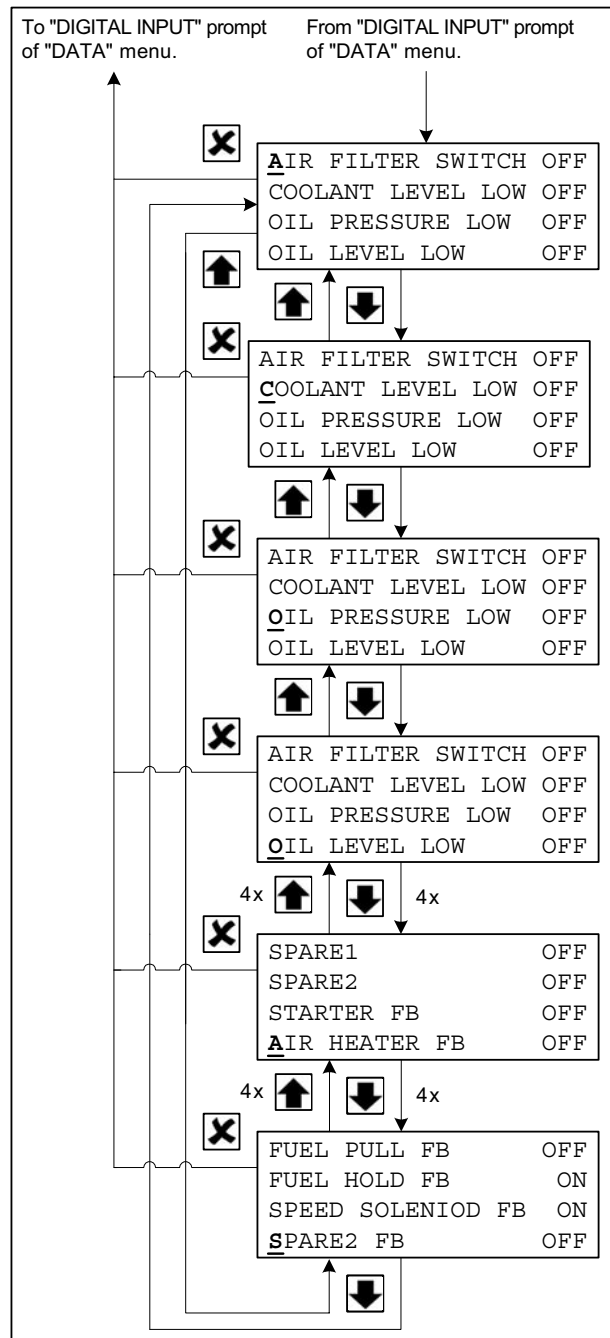

Figure 19: Digital Inputs

Digital Outputs

The Digital Outputs display the status of the following outputs:

- Bat. Charger
- Start Relay
- Preheat Relay
- Fuel Relay Pull
- Fuel Relay Hold
- Speed Solenoid

To enter the Digital Outputs complete the following steps:

1. Place the On/Off switch in the “ON” position.
2. Press the **ENTER** key or the **ESCAPE** key to enter the Main Menu, if necessary.
3. The Data Menu is typically the first menu displayed in the Main Menu.

NOTE: Press the UP or DOWN key to scroll up or down through the Main Menu to the Data Menu, if necessary.

4. Press the **ENTER** key to enter the Data Menu.
5. Press the **UP** or **DOWN** key to scroll up or down through the Data Menu to the Digital Outputs submenu.
6. Press the **ENTER** key to enter the Digital Outputs.
 - Press the **UP** or **DOWN** key to scroll up or down through the Digital Outputs.
 - Press the **ESCAPE** key to return to the Data Menu.

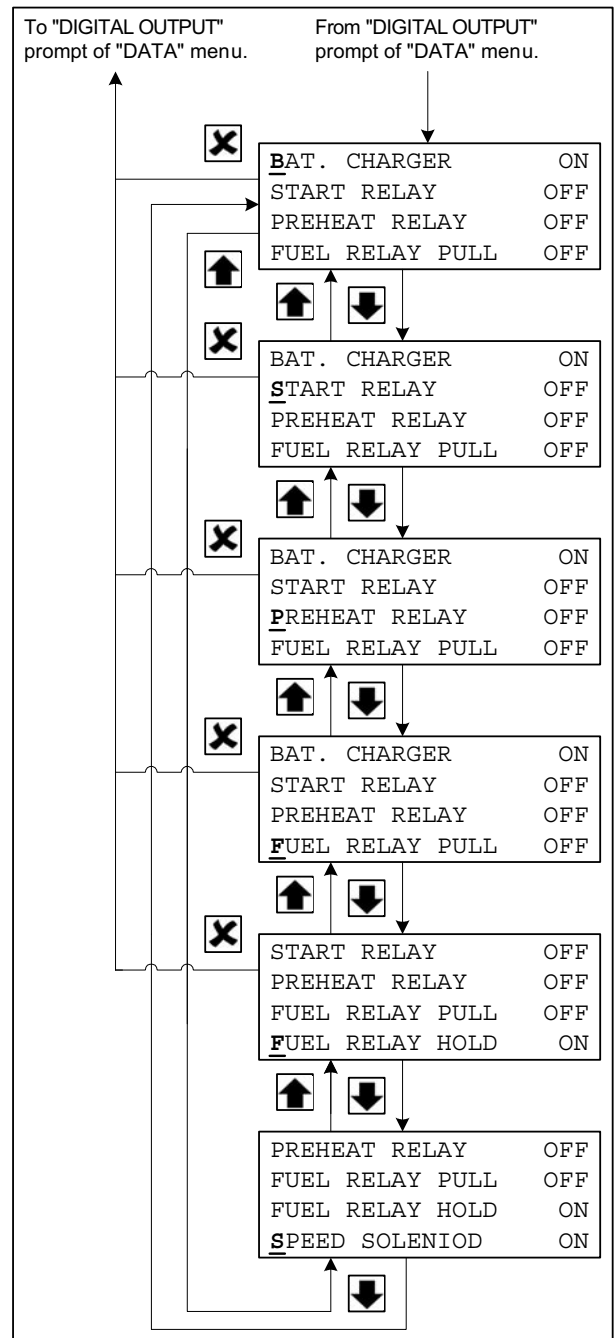

ARA1069

Figure 20: Digital Outputs

Internal States

The Internal States displays which of the following states the unit is in as it prepares to start, and after it starts or if it shuts down:

- INIT (Initiation Checks)
- Fuel Relay On
- Air Heater On
- Air Heater Off
- Restart 20 MI (Minutes)
- Running
- Shutdown
- HW Error
- Delay
- PTI
- RPM (Displayed Below the State)

To enter the Internal States complete the following steps:

1. Place the On/Off switch in the “ON” position.
2. Press the **ENTER** key or the **ESCAPE** key to enter the Main Menu, if necessary.
3. The Data Menu is typically the first menu displayed in the Main Menu.

NOTE: Press the UP or DOWN key to scroll up or down through the Main Menu to the Data Menu, if necessary.

4. Press the **ENTER** key to enter the Data Menu.
5. Press the **UP** or **DOWN** key to scroll up or down through the Data Menu to the Internal States submenu.
6. Press the **ENTER** key to enter the Internal States.
7. Press the **ESCAPE** key to return to the Data Menu.

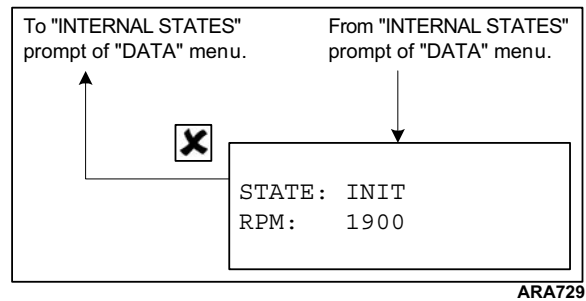

Figure 21: Internal States

ARA729

Alarm List Menu

The Alarm List Menu displays alarms. Alarms are recorded in the controller memory to simplify unit diagnostic procedures. The alarms are listed in the reverse order of their occurrence. The Alarm LED flashes if a shutdown alarm is present. Enter the Alarm List Menu to view the and acknowledge the alarms.

Alarm Types

There are two types of alarms:

Delayed Restart Alarm: Delayed restart alarms indicate the unit has stopped temporarily because of a problem or to prevent damage to the unit. The unit will attempt to restart in 20 minutes. The display will show information about the unit in the message screen and the time left to the restart attempt. A delayed restart alarm becomes a shutdown alarm after the third failed restart attempt in an hour.

Shutdown Alarm: The Alarm LED flashes and unit stops. Shutdown alarms indicate the unit has been stopped to prevent damage to the unit. The condition must be corrected before restarting the unit.

Displaying and Acknowledging Alarms

Enter the Alarm List Menu to view and acknowledge the alarms as follows:

1. Place the On/Off switch in the "ON" position.
2. Press the **ALARM** key to enter the Alarm List Menu directly.
Or
Enter the Alarm List Menu through the Main Menu as follows:
 - a. Press the **ENTER** key or the **ESCAPE** key to enter the Main Menu, if necessary.
 - b. Press the **UP** or **DOWN** key to scroll up or down through the Main Menu to the Alarm List Menu.
 - c. Press the **ENTER** key to enter the Alarm List Menu.

3. The Alarm List Menu will appear on the display. It shows the most recent alarm and the following information:
 - The alarm code (101 through 111)
 - The position of the alarm in the list of recorded alarms. For example, 1/2 means alarm one of two.
 - The alarm text
 - The alarm status (Active or Acknowledged).
4. Write down the alarm code and the alarm text.
5. Press the **ENTER** key to acknowledge the alarm. The Alarm LED will continue flashing until the active alarms (and messages) have been acknowledged.
6. Press the **DOWN** key to scroll down to the next alarm, if necessary.
7. Write down the alarm code and the alarm text.
8. Press the **ENTER** key to acknowledge the alarm.
9. Repeat steps 6 through 8 until all active alarms have been written down and acknowledged.
10. Press the **ESCAPE** key to return to the Main Menu.

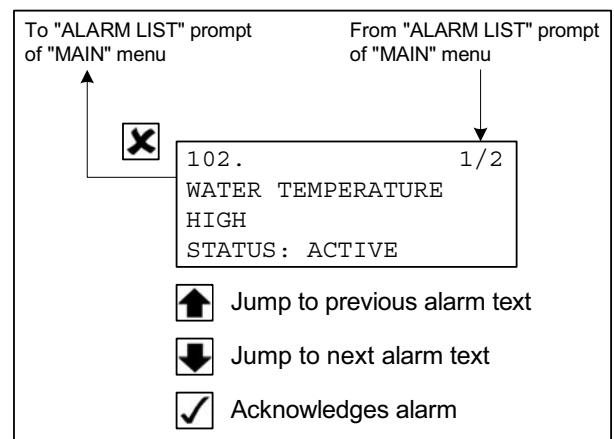

ARA753

Figure 22: Alarm List Menu

Alarm Diagnosis

The Alarm List on the following pages lists the alarms, their causes, and possible diagnosis.

Alarm List

Alarm Code and Text	Alarm Type–Cause	Diagnostics
101. WATER TEMPERATURE HIGH	Delayed Restart Alarm–Engine is running and water temperature is above 107 C (225 F) for 25 seconds. • Engine then stops and then attempts to restart.	1. Check for cause of engine overheating: <ul style="list-style-type: none">• Check engine coolant level.• Check water pump belt.• Check radiator for airflow and coolant flow restrictions. 2. Check for faulty water temperature sensor.
102. FAILED TO CRANK	Delayed Restart Alarm–Engine failed to crank. Becomes a Shutdown Alarm when number of restart attempts is greater than number of “Crank Restarts” set in Configuration Menu.	1. Check battery, battery cables, and starter. 2. Check 8S circuit. 3. Check Start Relay. 4. Check for seized engine or alternator.
103. FAILED TO START	Delayed Restart Alarm–Engine failed to crank. Becomes a Shutdown Alarm when number of restart attempts is greater than number of “Crank Restarts” set in Configuration Menu.	1. Check fuel level. 2. Check fuel solenoid, fuel pump, and fuel system both electrically and mechanically. 3. In cold ambient temperatures check for fuel gelling. 4. Check for restricted air cleaner or air intake system. 5. Check intake air heater.
104. RL2 (FUEL H) FEEDBACK FAILURE	Shutdown Alarm–No feedback when relay is energized, or feedback when relay is not energized.	1. Check RL2 (Fuel Hold) relay. 2. Check 8D circuit.
105. RL1 (FUEL P) FEEDBACK FAILURE	Shutdown Alarm–No feedback when relay is energized, or feedback when relay is not energized.	1. Check RL1 (Fuel Pull) relay. 2. Check 8DP circuit.
106. RL5 (STARTER) FEEDBACK FAILURE	Shutdown Alarm–No feedback when relay is energized, or feedback when relay is not energized.	1. Check RL5 (Start) relay. 2. Check SR, PSR, and FSR circuits.
107. EXTERNAL OVERLOAD	Shutdown Alarm–Message 122 has occurred 3 times.	1. Unplug load and attempt restart. 2. Check alternator field circuit. 3. Check alternator output circuit.
108. ENGINE NOT RUNNING REASON UNKNOWN	Delayed Restart Alarm–Input from Low Oil Pressure Switch is low (grounded) and RPM equals 0 when engine should be running. • Engine will attempt to restart in 20 minutes.	1. Check fuel level. 2. Check fuel solenoid, fuel pump, and fuel system both electrically and mechanically. 3. In cold ambient temperatures check for fuel gelling. 4. Check for seized engine or alternator.

Alarm List (Continued)

Alarm Code and Text	Alarm Type–Cause	Diagnostics
109. LOW OIL LEVEL	If low oil level and low oil pressure is present at the same time.	<ol style="list-style-type: none"> 1. Check oil level. 2. Check Oil Level Switch. 3. Check circuits to Oil Level Switch. 4. Check oil pressure using the Analog Inputs submenu of the Data Menu. 5. Check Low Oil Pressure Switch. 6. Check OPS circuit.
110. RPM BELOW LIMIT	Shutdown Alarm–Unit attempted 3 restarts that failed.	<ol style="list-style-type: none"> 1. Check engine speed. 2. Check RPM sensor.
111. FAILED TO START LOW BATTERY	Controller is reset 3 times during cranking.	<ol style="list-style-type: none"> 1. Defective battery, load test battery. 2. Controller not charging battery. 3. Check ground connections at block.
112. WATER TEMPERATURE SENSOR FAILURE	Message 113 has occurred 3 times.	<ol style="list-style-type: none"> 1. Check sensor circuits and wiring connections. 2. Check for faulty sensor.
113. COOLANT LEVEL LOW	Coolant level low after message 113.	<ol style="list-style-type: none"> 1. Check coolant level. 2. Check Coolant Level Sensor. 3. Check circuits to Coolant Level Sensor.
114. INTERNAL OVERLOAD	Message 132 has occurred 3 times.	<ol style="list-style-type: none"> 1. See “Alternator Diagnosis” on page 117.

Message List Menu

The Message List Menu displays messages. Messages are recorded in the controller memory to simplify unit diagnostic procedures. The messages are listed in the reverse order of their occurrence. Enter the Message List Menu to view the and acknowledge the messages. Acknowledging a message clears it from the list.

NOTE: The unit will not start a PTI until all active messages have been acknowledged. The display will show “ACKNOWLEDGE MESSAGE” if there are messages that have not been acknowledged when trying to start a PTI.

Displaying and Acknowledging Messages

Enter the Message List Menu to view and acknowledge the messages as follows:

1. Place the On/Off switch in the “ON” position.
2. Press the **ENTER** key or the **ESCAPE** key to enter the Main Menu, if necessary.
3. Press the **UP** or **DOWN** key to scroll up or down through the Main Menu to the Message List Menu.
4. Press the **ENTER** key to enter the Message List Menu.
5. The Message List Menu will appear on the display. It shows the most recent message and the following information:
 - The message code (101 through 131)
 - The position of the message in the list of recorded messages. For example, 1/1 means message one of one.
 - The message text
 - The message status (Active or Acknowledged).
6. Write down the message code and the message text.
7. Press the **ENTER** key to acknowledge the message. The Alarm LED will continue flashing until the active messages (and alarms) have been acknowledged.

8. Press the **DOWN** key to scroll down to the next message, if necessary.
9. Write down the message code and the message text.
10. Press the **ENTER** key to acknowledge the message.
11. Repeat steps 8 through 10 until all active messages have been written down and acknowledged.
12. Press the **ESCAPE** key to return to the Main Menu.
13. The unit will then enter the Start Sequence and start the engine.

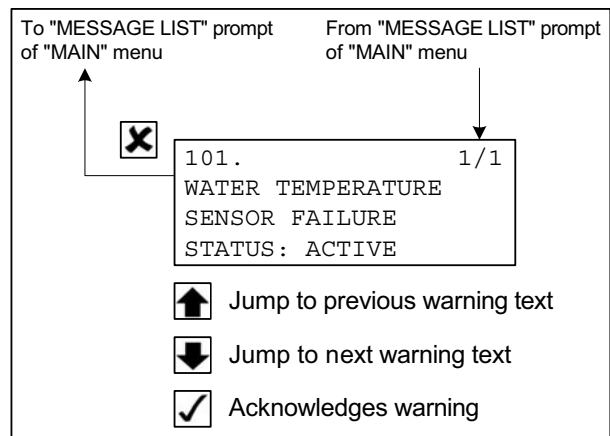

ARA754

Figure 23: Message List Menu

Message Diagnosis

The Message List on the following pages lists the messages, their causes, and possible diagnosis.

Message List

Message Code and Text	Cause	Diagnostics
101. BAT. VOLTAGE LOW	Battery Voltage is below 9 volts.	1. Check battery 2. Check battery cables.
102. DIGITAL INPUT FAILURE	Digital inputs have been changing once a second for the last 10 seconds.	This condition indicates noise on the line, a loose connection, or a bad sensor.
103. OUTPUT VOLTAGE < 180 V	The engine is running and the exciter field is energized, but the output voltage is below 360 volts for 30 seconds.	Check alternator for low output.
104. AIR FILTER BLOCKED	Not used.	
105. COOLANT LEVEL LOW	Coolant Level Sensor indicates low coolant level for 30 seconds.	1. Check coolant level. 2. Check Coolant Level Sensor. 3. Check circuits to Coolant Level Sensor.
106. OUTPUT FREQUENCY LOW	Output frequency is below 45 Hz for 30 seconds (engine RPM below 1350).	Check and adjust engine speed.
107. OUTPUT FREQUENCY HIGH	Output frequency is above 70 Hz for 30 seconds (engine RPM above 2100).	Check and adjust engine speed.
108. LOW OIL LEVEL	Oil Level Switch indicates low oil level for 3 minutes.	1. Check oil level. 2. Check Oil Level Switch. 3. Check circuits to Oil Level Switch.
109. HOUR METER 1 HAS EXCEEDED THRESHOLD	Hour Meter 1 (HM1) has exceeded the threshold set in the Configuration Menu.	Acknowledge message to reset timer.
110. HOUR METER 2 HAS EXCEEDED THRESHOLD	Hour Meter 2 (HM2) has exceeded the threshold set in the Configuration Menu.	Acknowledge message to reset timer.
111. FUEL LEVEL LOW	Fuel Level is below "Fuel Level" set in Configuration Menu.	1. Check fuel level. 2. Check Fuel Level Sensor. 3. Check circuits to Fuel Level Sensor.
112. ENGINE RPM SENSOR FAILURE	Engine is running and input from Low Oil Pressure Switch is high (grounded), but RPM is below 800.	1. Check RPM Sensor. 2. Check circuits to RPM Sensor.
113. WATER TEMPERATURE SENSOR FAILURE	Water temperature sensor reading is below -40 C (-40 F) or above 115 C (240 F).	1. Check sensor circuits and wiring connections. 2. Check for faulty sensor.
114. LOW OIL PRESSURE	Engine is running and input from Low Oil Pressure Switch is low (grounded) for 60 seconds.	1. Check oil level. 2. Check oil pressure using the Analog Inputs submenu of the Data Menu. 3. Check Low Oil Pressure Switch. 4. Check OPS circuit.

Message List (Continued)

Message Code and Text	Cause	Diagnostics
115. RL6 (AIRHEAT) FEEDBACK FAILURE	No feedback when relay is energized, or feedback when relay is not energized.	1. Check RL6 (Preheat) relay. 2. Check PHR, PPHR, and FPHR circuits.
116. COUNTDOWN TIMER HAS EXPIRED	If hour counter exceeds user setup.	1. Acknowledge message and reset timer.
117. OIL PRESSURE HIGH WHILE ENG. IS NOT RUNNING	During PTI input from Low Oil Pressure Switch is high (not grounded) when the engine was not running.	1. Check Low Oil Pressure Switch. 2. Check OPS circuit.
118. OIL PRESSURE SWITCH FAILURE	Input from Low Oil Pressure Switch is high (not grounded) before engine starts.	1. Check Low Oil Pressure Switch. 2. Check OPS circuit.
119. WATER TEMPERATURE HIGH	If water temp. >107 C for 5 sec. - restarting.	1. Check water temperature sensor. 2. Check WTP/WTN circuit.
120. ENGINE FAILED TO CRANK	Engine failed to crank.	1. Check battery, battery cables, and starter. 2. Check 8S circuit. 3. Check Start Relay. 4. Check for seized engine or alternator.
121. ENGINE FAILED TO START	No oil pressure and did not reach 800 RPM - restarting.	1. Check fuel level. 2. Check fuel solenoid, fuel pump, and fuel system both electrically and mechanically. 3. In cold ambient temperatures check for fuel gelling. 4. Check for restricted air cleaner or air intake system. 5. Check intake air heater.
122. EXTERNAL OVERLOAD	If output is short-circuited - restarting.	1. Unplug load and attempt restart. 2. Check alternator field circuit. 3. Check alternator output circuit.
123. ENGINE STOPPED REASON UNKNOWN	If oil pressure low and no RPM, while running - restarting.	1. Check fuel level. 2. Check fuel solenoid, fuel pump, and fuel system both electrically and mechanically. 3. In cold ambient temperatures check for fuel gelling. 4. Check for seized engine or alternator.
124. NO LOAD RPM LESS THEN 1530	RPM less than 1530 after startup.	1. Check engine speed. 2. Check RPM sensor.

Message List (Continued)

Message Code and Text	Cause	Diagnostics
125. RL3 (SPEED SOLENOID) FEEDBACK FAILURE	No feedback when relay is energized, or feedback when relay is not energized.	1. Check RL3 (Speed [Throttle] Solenoid) relay. 2. Check 7D circuit.
126. FUEL LEVEL SENSOR OUT OF RANGE	Fuel level reading is above the maximum tank value.	1. Check fuel level sensor. 2. Check FPOS, FNEG, and FOUT circuits. 3. Check fuel tank size setting in System Setup submenu.
127. FUEL LEVEL DECREASED TO FAST	Fuel level reading decreased faster than normally expected. <i>NOTE: Must use password (0007) to clear this message.</i>	1. Check for leak in fuel tank. 2. Check to see if fuel has been removed from fuel tank.
128. SPEED SOLENOID FAILURE	During PTI if HIGH speed is same as LOW speed.	1. Check throttle solenoid. 1. Check TS circuit.
129. RPM BELOW LIMIT	RPM is below 1350 for 5 sec.	1. Check engine speed. 2. Check RPM sensor.
130. DELAYED OUTPUT TIMED OUT	Water temperature sensor is below 32 C (90 F) for 5 minutes.	1. Check water temperature sensor. 2. Check WTS circuit.
131. RL5 (STARTER) FEEDBACK FAILURE	No feedback when RL5 relay is energized.	1. Check RL5 (Starter Solenoid) relay. 2. Check 2A and 8S circuits.
132. INTERNAL OVERLOAD	Field current (F1 – F2) is more than 1.75 amps.	1. See “Alternator Diagnosis” on page 117.

Commands Menu

The Commands Menu contains the following submenus that are used to test the operation of the unit and controller:

- PTI (Pretrip Inspection Test)
- Manual Function Test
- System Setup

To enter the Commands Menu complete the following steps:

1. Place the On/Off switch in the “ON” position.
2. Press the **ENTER** key or the **ESCAPE** key to enter the Main Menu, if necessary.

3. Press the **UP** or **DOWN** key to scroll up or down through the Main Menu to the Commands Menu.
4. Press the **ENTER** key to enter the Commands Menu.
5. The PTI submenu will be displayed.
 - Press the **ENTER** key to start the PTI.
 - Press the **UP** or **DOWN** key to scroll up or down through the Commands Menu.
 - Press the **ESCAPE** key to return to the Main Menu.

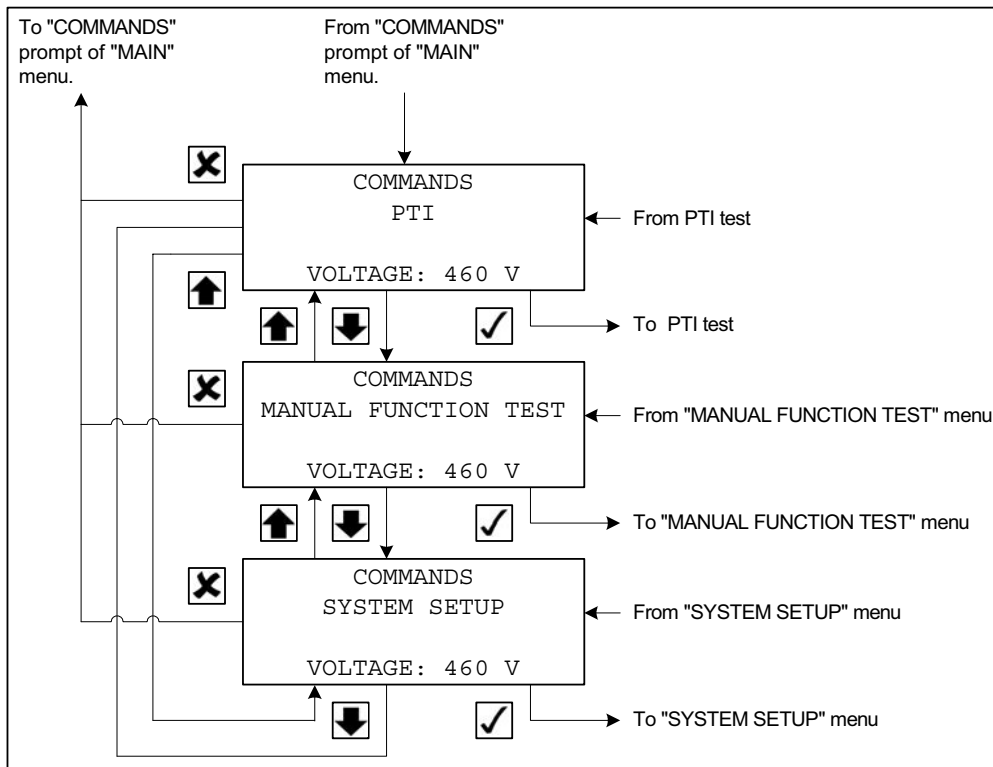

ARA1070

Figure 24: Commands Menu

PTI

The PTI (Pretrip Inspection Test) initiates a test of the unit’s electrical, engine, and alternator system components. To perform a PTI complete the following steps:

NOTE: The unit will not start a PTI until all active messages have been acknowledged. The display will show “ACKNOWLEDGE MESSAGE” if there are messages that have not been acknowledged when trying to perform a PTI. See “Displaying and Acknowledging Messages” on page 54.

1. Place the On/Off switch in the “ON” position.
2. Press the **ENTER** key or the **ESCAPE** key to enter the Main Menu, if necessary.
3. Press the **UP** or **DOWN** key to scroll up or down through the Main Menu to the Commands Menu.
4. Press the **ENTER** key to enter the Commands Menu.
5. The PTI submenu will be displayed.
6. Press the **ENTER** key to start the PTI.
7. The controller then performs the PTI. Observe the unit for proper operation and functions during the PTI. The display shows which component is being tested, and the test result (PASSED or FAILED).
 - a. The engine stops.
 - b. The controller beeps to test the buzzer.
 - c. A display test is performed. Watch the display to verify it is operating properly.
 - d. The oil level switch is tested.
 - e. The oil pressure switch is tested.
 - f. The coolant temperature sensor is tested.
 - g. The coolant level is tested.
 - h. Test speed solenoid relay, if detected.
 - i. The preheat relay is tested.
 - j. The fuel hold relay is tested.
 - k. The fuel pull relay is tested.
 - l. Test fuel level, if selected.

- m. The start relay is tested.
- n. The output voltage is tested.
- o. The engine starts.
- p. The display says “PASSED OUTPUT VOLTAGE TEST” if the output voltage is acceptable.
- q. The oil pressure switch is tested.
- r. Test speed solenoid high and low, if detected.

NOTE: If a component fails its test, the PTI will stop at that point and display “FAILED - REBOOT”. Correct the problem and repeat the PTI by pressing the ENTER Key.

8. When the PTI is complete, the test ends automatically and the controller display shows “PTI PASSED (or FAILED) - REBOOT”. Turn the On/Off Switch Off and back On to reboot and return the unit to normal operation.
9. If an operating problem occurs during the PTI, view and correct any alarms or messages. Then acknowledge the alarms or messages and repeat the PTI.

NOTE: Acknowledge the alarms or messages ONLY after the alarm codes are documented and problems repaired.

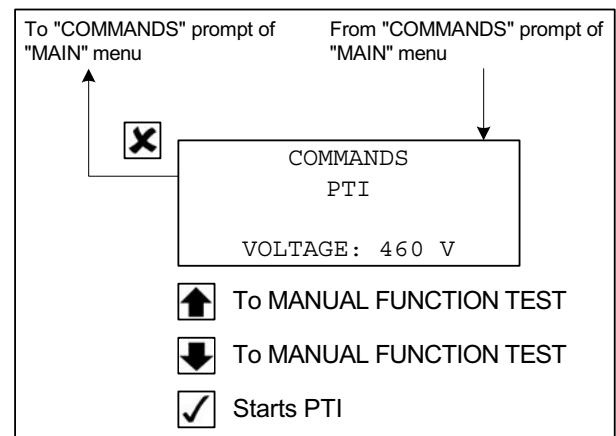

ARA984

Figure 25: PTI Submenu

Manual Function Test

The Manual Function Test submenu contains the following component tests:

- Display Test
- Preheat Relay Test
- Fuel Hold Relay Test
- Fuel Pull Relay Test
- Start Relay Test
- Force Speed (Energizes or de-energizes the speed solenoid to change the engine speed.)

The test result (PASSED or FAILED) is displayed after a test is performed. To enter the Manual Function Test complete the following steps:

1. Place the On/Off switch in the “ON” position.
2. Press the **ENTER** key or the **ESCAPE** key to enter the Main Menu, if necessary.
3. Press the **UP** or **DOWN** key to scroll up or down through the Main Menu to the Commands Menu.
4. Press the **ENTER** key to enter the Commands Menu.
5. The PTI submenu will be displayed.
6. Press the **UP** or **DOWN** key to scroll up or down through the Commands Menu to the Manual Function Test submenu.
7. Press the **ENTER** key to enter the Manual Function Test.
 - The engine will stop if it is running.
 - The Display Test is the first to appear. Press the **ENTER** key to perform the Display Test.
 - Press the **UP** or **DOWN** key to scroll up or down through the Manual Function Test submenu. Press the **ENTER** key to perform the selected test.
 - Press the **ESCAPE** key to return to the Commands Menu.

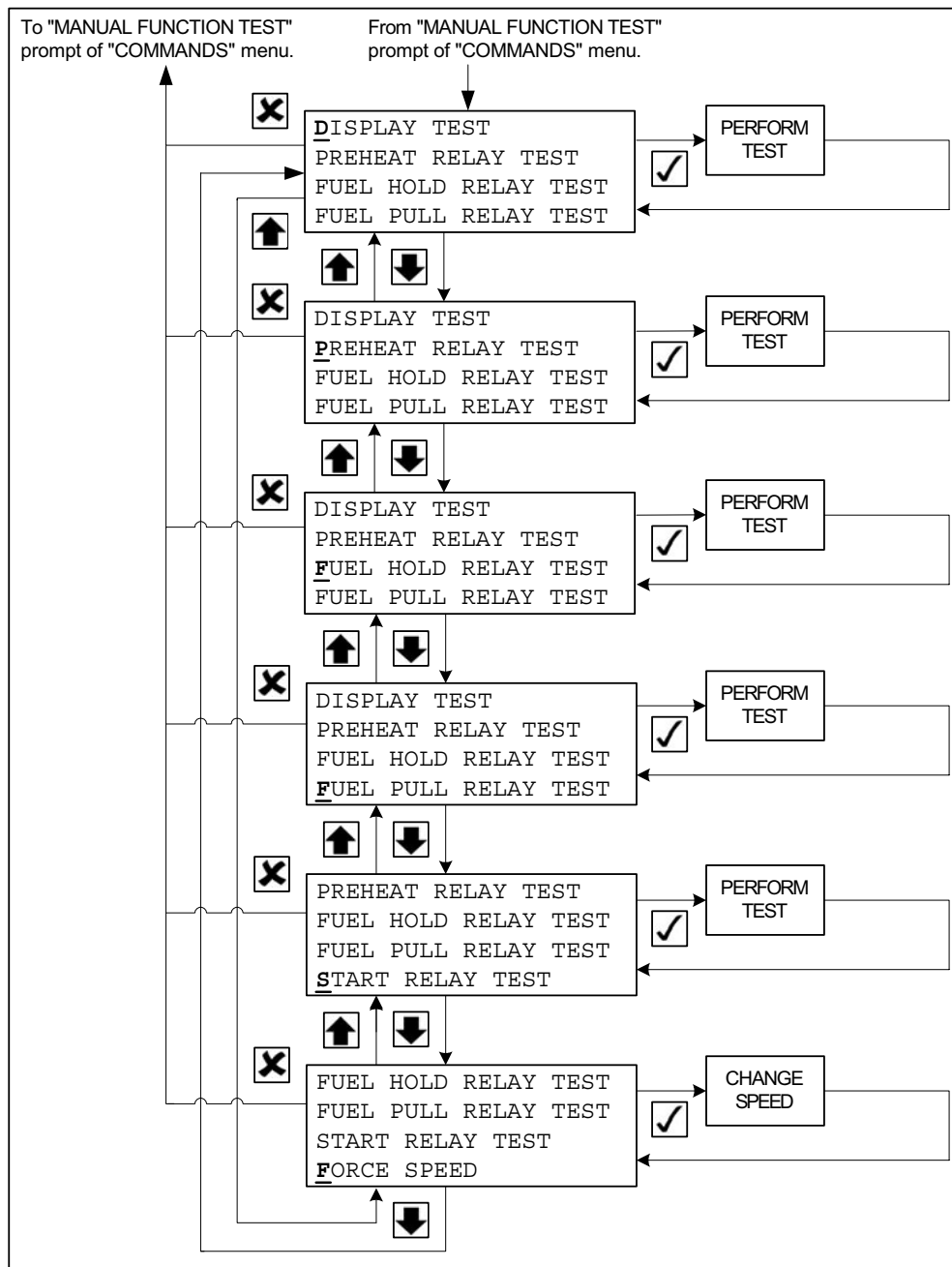

ARA1071

Figure 26: Manual Function Test Submenu

System Setup

The System Setup submenu contains the following:

- Current RPM, which is used to check the engine speed.
- Speed Solenoid (On/Off), which is used to energize and de-energize the speed solenoid when checking or adjusting the engine speeds.
- Tank Size (50/75/80/125), which is used to set the unit fuel tank size.
- Fuel Sensor (Yes/No), which is used to setup units with a fuel sensor. Unit with fuel sensor Yes, unit without fuel sensor No.
- Throttle Solenoid (Yes/No), which is used to setup units with EcoPower. Unit with solenoid Yes, unit without solenoid No.
- Date, which is used to set the date. See “Date/Time” on page 64 for information about setting the date.
- Time, which is used to set the time. See “Date/Time” on page 64 for information about setting the time.
- ID Number, which is used to set an ID number to identify the unit when downloading the event logger.
- Serial Number, which is used to set the unit serial number.

NOTE: The controller returns the Date/Time to the default setting when the battery is disconnected.

To enter the System Setup submenu complete the following steps:

1. Place the On/Off switch in the “ON” position.
2. Press the **ENTER** key or the **ESCAPE** key to enter the Main Menu, if necessary.
3. Press the **UP** or **DOWN** key to scroll up or down through the Main Menu to the Commands Menu.

4. Press the **ENTER** key to enter the Commands Menu.
 5. The PTI submenu will be displayed.
 6. Press the **UP** or **DOWN** key to scroll up or down through the Commands Menu to the System Setup submenu.
 7. Press the **ENTER** key to enter the System Setup submenu.
 8. Press the **UP** or **DOWN** key to scroll up or down through the System Setup submenu.
 9. Press the **ENTER** key to enter the selected function.
 - Press the **UP** or **DOWN** key to change the value of the selected function. See “Date/Time” on page 64 for information about setting the date and time.
- NOTE: The engine speed will change when the UP or Down key is pressed.***
- Press the **ESCAPE** key and the **ENTER** key at the same time to save the new Tank Size setting.
- NOTE: Press the ESCAPE key to return to the System Setup submenu without saving the new settings.***
- Press the **ESCAPE** key to return to the System Setup submenu.

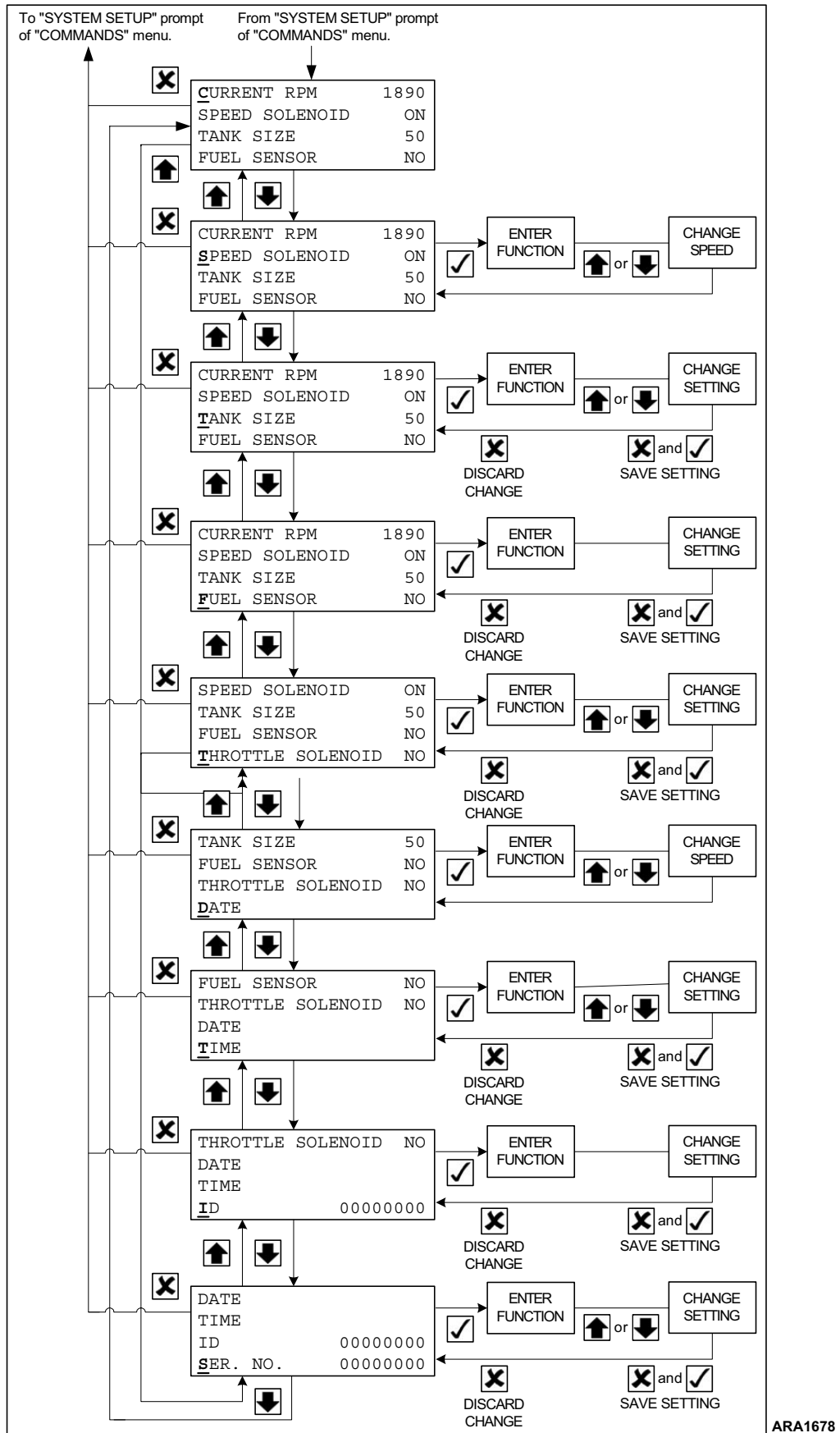

ARA1678

Figure 27: System Setup Submenu

Date/Time

The Date/Time submenu is used to set the clock in the controller. To enter the Date/Time submenu and set the clock complete the following steps:

1. Place the On/Off switch in the “ON” position.
2. Press the **ENTER** key or the **ESCAPE** key to enter the Main Menu, if necessary.
3. Press the **UP** or **DOWN** key to scroll up or down through the Main Menu to the Commands Menu.
4. Press the **ENTER** key to enter the Commands Menu.
5. The PTI submenu will be displayed.
6. Press the **UP** or **DOWN** key to scroll up or down through the Commands Menu to the System Setup submenu.
7. Press the **ENTER** key to enter the System Setup submenu.
8. Press the **UP** or **DOWN** key to scroll up or down through the System Setup submenu to the Date/Time submenu.
9. Press the **ENTER** key to enter the Date/Time submenu to set the clock.
10. Press the **ENTER** key to move the cursor (to the right or down at the end of a row) to select the value you want to change.

NOTE: The ENTER key does not move the cursor to the right in the Time value. You must use the UP or DOWN keys to scroll the total Time value up or down.

11. Press the **UP** or **DOWN** key to scroll the selected value up or down to the new setting.
12. Repeat steps 10 and 11 until you have changed all the values to the new settings.
13. Press the **ESCAPE** key and the **ENTER** key at the same time to save the new settings and return to the System Setup submenu.

NOTE: Press the ESCAPE key to return to the System Setup submenu without saving the new settings.

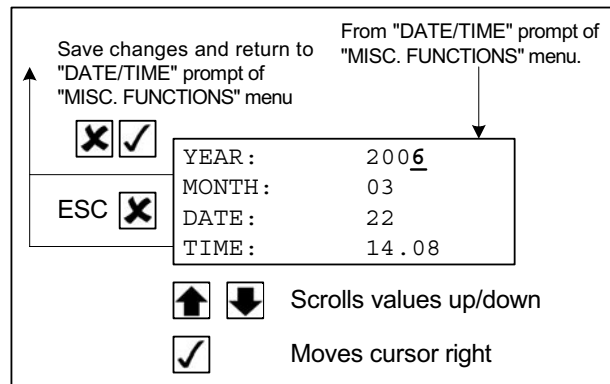

ARA736

Figure 28: Date/Time

Misc. Functions Menu

The Misc. Functions Menu contains the following submenus:

- C/F Mode
- SW/HW (Software/Hardware) Version
- Timers/Counters

To enter the Misc. Functions complete the following steps:

1. Place the On/Off switch in the “ON” position.
2. Press the **ENTER** key or the **ESCAPE** key to enter the Main Menu, if necessary.

3. Press the **UP** or **DOWN** key to scroll up or down through the Main Menu to the Misc. Functions Menu.
4. Press the **ENTER** key to enter the Misc. Functions Menu.
5. The C/F Mode submenu will be displayed.
 - Press the **ENTER** key to enter C/F Mode submenu to set the controller for Celsius or Fahrenheit units.
 - Press the **UP** or **DOWN** key to scroll up or down through the Misc. Functions Menu.
 - Press the **ESCAPE** key to return to the Main Menu.

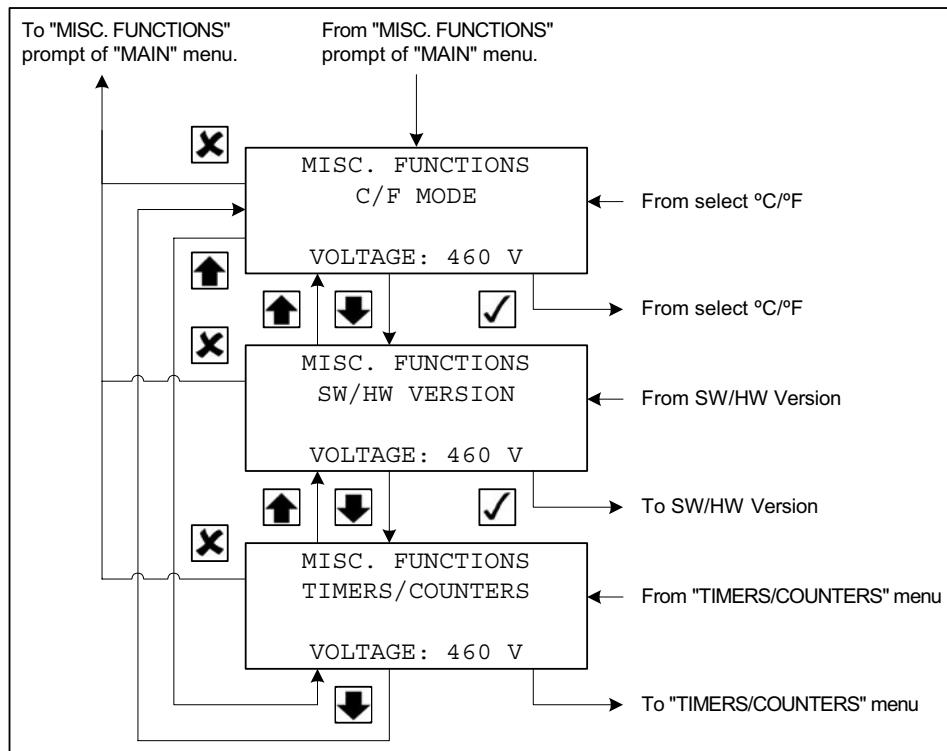

ARA1105

Figure 29: Misc. Functions Menu

C/F Mode

The C/F Mode submenu is used to select whether Celsius or Fahrenheit units are used to display temperature readings. To enter the C/F Mode submenu and change the units displayed complete the following steps:

1. Place the On/Off switch in the “ON” position.
2. Press the **ENTER** key or the **ESCAPE** key to enter the Main Menu, if necessary.
3. Press the **UP** or **DOWN** key to scroll up or down through the Main Menu to the Misc. Functions Menu.
4. Press the **ENTER** key to enter the Misc. Functions Menu.
5. The C/F Mode submenu will be displayed.
6. Press the **ENTER** key to enter C/F Mode to change the units displayed.
7. Press the **UP** or **DOWN** key to toggle between the Celsius and Fahrenheit settings.
8. Press the **ESCAPE** key and the **ENTER** key at the same time to save the new setting and return to the Misc. Functions Menu.

NOTE: Press the **ESCAPE** key to return to the Misc. Functions Menu without saving the new setting.

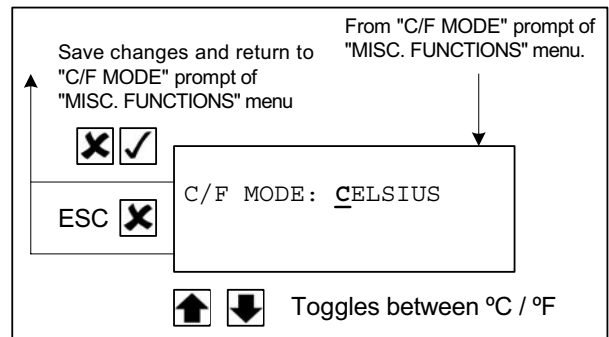

ARA737

Figure 30: C/F Mode

SW/HW Version

The SW/HW Version submenu displays the following information about the controller:

- SW (Software Version)
- HARDWARE REV. (Hardware Revision)

To enter the Program Version submenu complete the following steps:

1. Place the On/Off switch in the “ON” position.
2. Press the **ENTER** key or the **ESCAPE** key to enter the Main Menu, if necessary.
3. Press the **UP** or **DOWN** key to scroll up or down through the Main Menu to the Misc. Functions Menu.
4. Press the **ENTER** key to enter the Misc. Functions Menu.
5. Press the **UP** or **DOWN** key to scroll up or down through the Misc. Functions Menu to the Program Version submenu.
6. Press the **ENTER** key to enter the Program Version submenu.
7. Press the **ESCAPE** key to return to the Misc. Functions Menu.

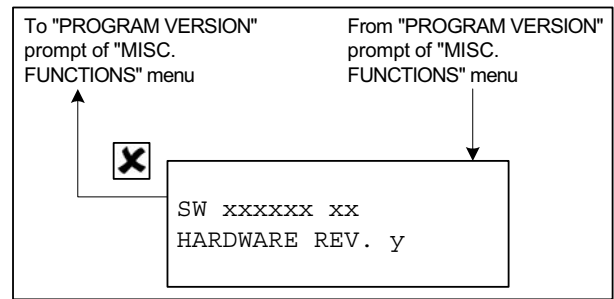

ARA738

Figure 31: SW/HW Version

Timers/Counters

The Timers/Counters submenu displays the following information about the hourmeters and restart counters:

- Run Hours – The number of hours the unit has been running.
- Hour Meter 1 – The number of hours the unit has been running since Hour Meter 1 was cleared. A message is generated when the reading reaches the threshold set in the Configuration Menu.
- Hour Meter 2 – The number of hours the unit has been running since Hour Meter 2 was cleared. A message is generated when the reading reaches the threshold set in the Configuration Menu.
- Engine Off Hours – The number of hours the unit has been running since Engine Off Hours was cleared. An alarm is generated when the reading reaches the threshold set in the Configuration Menu.
- Restarts – The number of restarts the controller has made since the last power up.
- Total Restarts – The total number of restarts.
- Run Hours 50 Hz – The number of hours the unit has been running at 50 Hz (low speed).
- Run Hours 60 Hz – The number of hours the unit has been running at 60 Hz (high speed).

NOTE: The readings for Run Hours, Run Hours 50 Hz, and Run Hours 60 Hz can be adjusted. See “Setting Hour Meter Thresholds and Resetting Hour Meters” on page 72.

To enter the Timers/Counters submenu complete the following steps:

1. Place the On/Off switch in the “ON” position.
2. Press the **ENTER** key or the **ESCAPE** key to enter the Main Menu, if necessary.
3. Press the **UP** or **DOWN** key to scroll up or down through the Main Menu to the Misc. Functions Menu.
4. Press the **ENTER** key to enter the Misc. Functions Menu.

5. Press the **UP** or **DOWN** key to scroll up or down through the Misc. Functions Menu to the Timers/Counters submenu.
6. Press the **ENTER** key to enter the Timers/Counters submenu.
 - Press the **UP** or **DOWN** key to scroll up or down through the Timers/Counters.
 - Press the **ESCAPE** key to return to the Misc. Functions Menu.

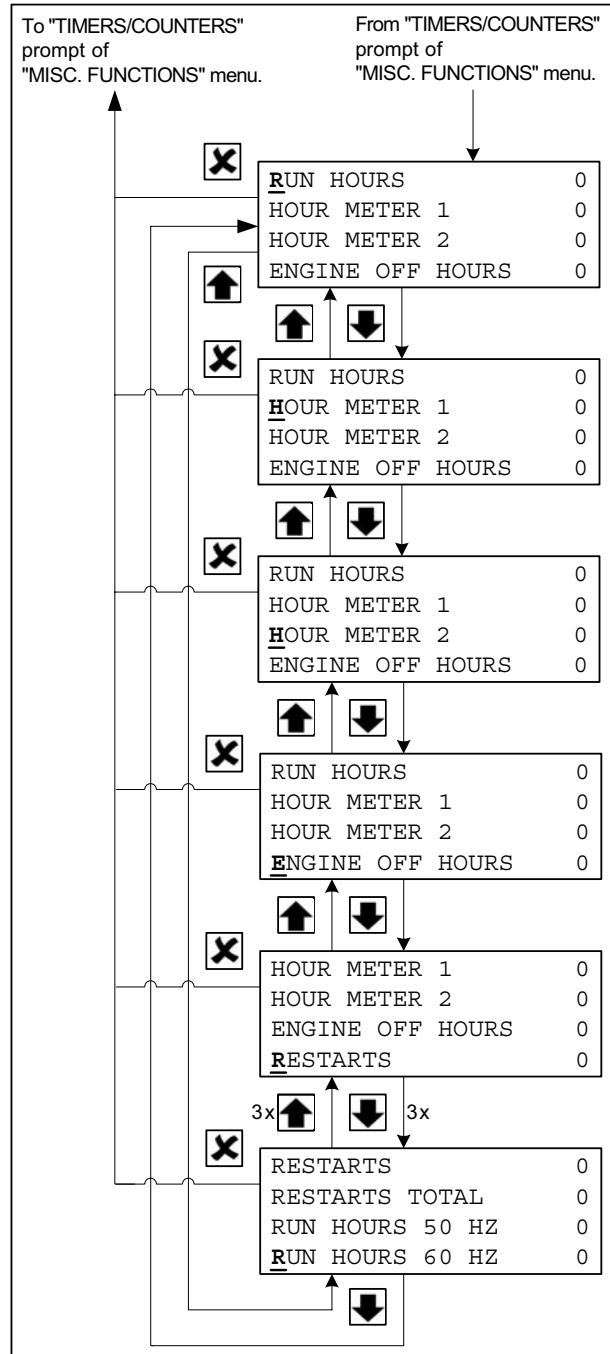

ARA1073

Figure 32: Timers/Counters

Configuration Menu

The Configuration Menu is used to configure the following controller functions (also see the flowcharts on the following pages):

NOTE: The Configuration Menu requires that a password (0007) be used change a setting. See “Setting Hour Meter Thresholds and Resetting Hour Meters” on page 72 for an example of how change a setting.

- LOP (Low Oil Pressure) Restart – The default setting is OFF.
- DEL (Delayed) Coldstart – The default setting is ON. When this is set to ON, the controller will delay energizing the exciter field until the Water Temperature reaches 32 C (90 F).
- HM1 (Hour Meter 1) Threshold – The default setting is 0. When this is set to anything other than 0, it sets the threshold that generates the message “113. HOUR METER 1 HAS EXCEEDED THRESHOLD”.
- HM2 (Hour Meter 2) Threshold – The default setting is 0. When this is set to anything other than 0, it sets the threshold that generates the message “114. HOUR METER 2 HAS EXCEEDED THRESHOLD”.
- ENG (Engine) Off Hours – The default setting is 0. When this is set to anything other than 0, it sets the threshold that generates the alarm “110. ENGINE STOPPED DUE TO USER SETUP”.
- Factory Reset – The default setting is OFF. When this is set to ON, the controller will reset all run timers to 0 when the unit is turned Off and then back On.
- APU Connected – The default setting is OFF. This is not used.
- Output Voltage – The default setting is 460. The other selection is 230, which is used if the alternator is configured for an output voltage of 230 Vac.
- Fuel Sensor – The default setting is OFF. This is set to ON if the unit is equipped with a fuel level sensor.
- Fuel Level – The default setting is 0. Possible settings are 1 to 400 gallons. This sets the threshold that generates the alarm “115. FUEL LEVEL LOW”.
- Crank Restarts – The default setting is 3. Possible settings are 0 to 15, and 0 equals infinite. This sets the number of restart attempts that are allowed.
- Telematic – The default setting is OFF. This is not used.

To enter the Configuration Menu complete the following steps:

1. Place the On/Off switch in the “ON” position.
2. Press the **ENTER** key or the **ESCAPE** key to enter the Main Menu, if necessary.
3. Press the **UP** or **DOWN** key to scroll up or down through the Main Menu to the Configuration Menu.
4. Press the **ENTER** key to enter the Configuration Menu.
5. See “Setting Hour Meter Thresholds” on page 73 for an example of how change a setting.

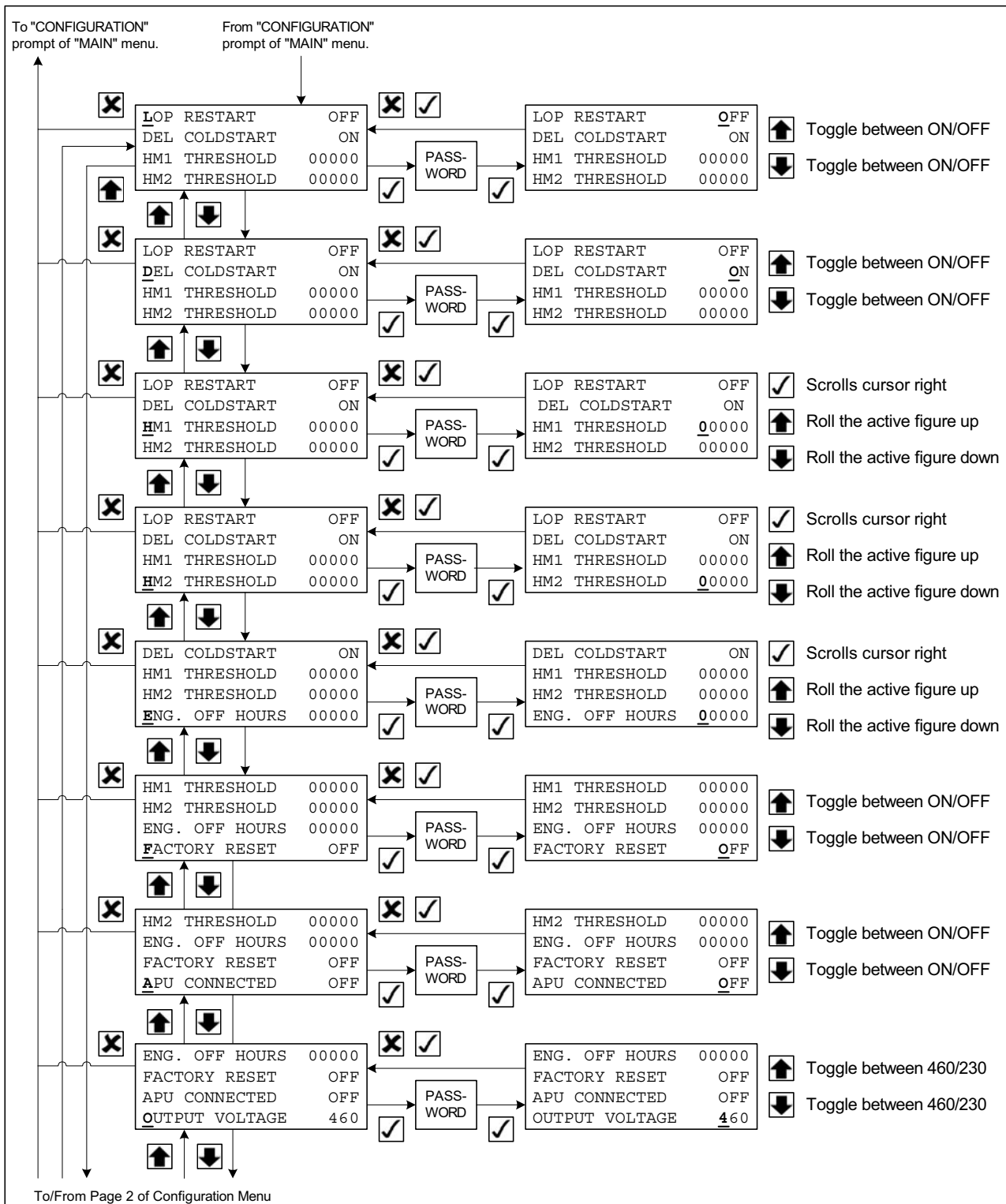

ARA1080

Figure 33: Configuration Menu (Page 1)

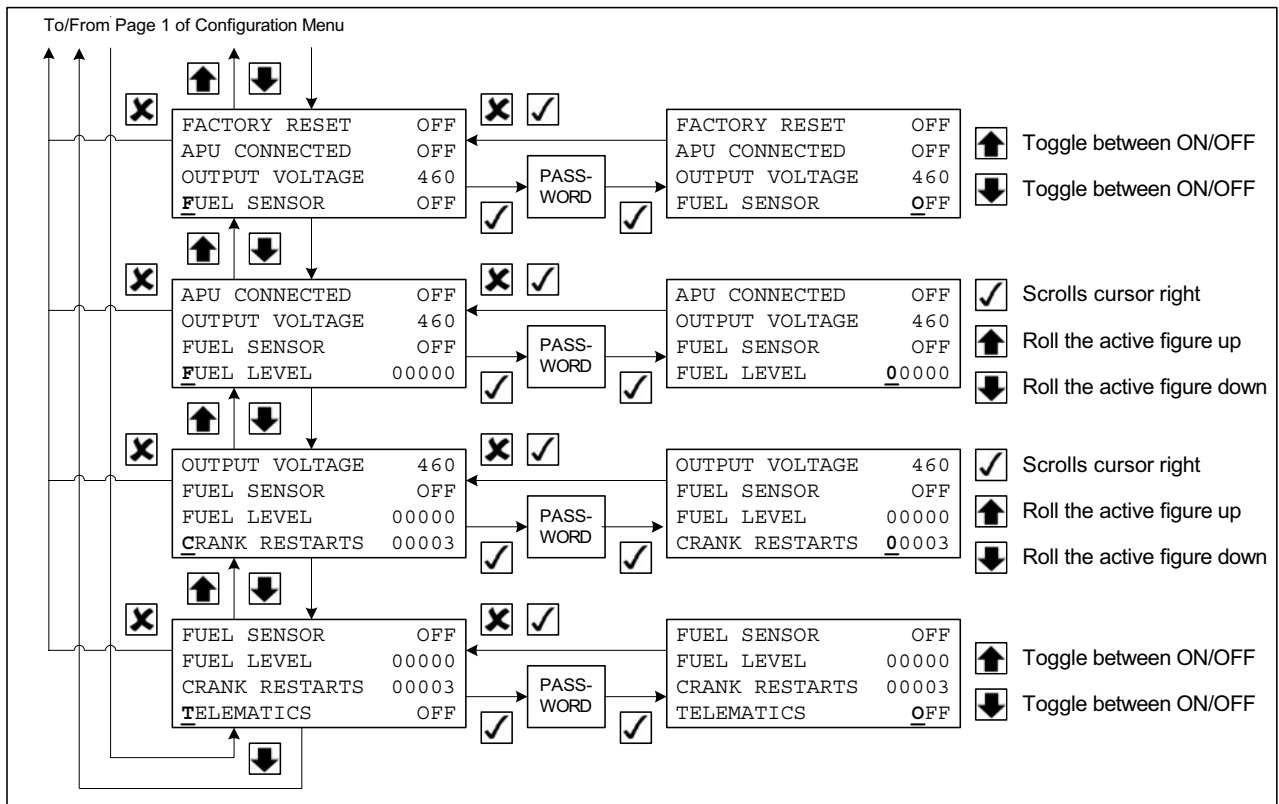

ARA1106

Figure 34: Configuration Menu (Page 2)

Setting Hour Meter Thresholds and Resetting Hour Meters

The Hour Meter Threshold feature sets the controller to alert the user that the unit has operated for a defined number of hours. The number of operating hours are entered in the controller in the Hour Meter Threshold display. The controller then generates a message when the hour meter reaches the threshold setting.

NOTE: If the user does not desire to use the Hour Meter Threshold feature to measure maintenance intervals, etc., leave the settings at “00000” to avoid nuisance messages.

The readings for Run Hours, Run Hours 50 Hz, and Run Hours 60 Hz can be adjusted.

To set the HM1 Threshold or the HM2 Threshold, or to reset Run Hours, Run Hours 50 Hz, or Run Hours 60 Hz, complete the following steps.

1. Place the On/Off switch in the “ON” position.
2. Press the **ENTER** key or the **ESCAPE** key to enter the Main Menu, if necessary.
3. Press the **UP** or **DOWN** key to scroll up or down through the Main Menu to the Configuration Menu.
4. Press the **ENTER** key to enter the Configuration Menu.
5. The Configuration Menu will be displayed with the cursor on LOP Restart.
6. Press the **UP** or **DOWN** key to scroll up or down through the Configuration Menu to HM1 Threshold, HM2 Threshold, Run Hours, Run Hours 50 Hz, or Run Hours 60 Hz.
7. Press the **ENTER** key to display the Password screen.
8. Enter the password, which is 0007. To enter the password press the **ENTER** key to move the cursor to the last value and press the **UP** or **DOWN** key to scroll the value to 7. Press the **ESCAPE** key and the **ENTER** key at the same time to enter the password.
9. The cursor will be under the H of the HM1 or HM2 Threshold selection, or under the R of the Run Hours, Run Hours 50 Hz or Run Hours 60 Hz selection.

10. Press the **ENTER** key to move the cursor to select the value you want to change.

NOTE: For example, to change the setting for the HM1 Threshold to 400 hours, press the ENTER key until the cursor is under the third digit from the right. Then press the UP key until that value reads 4.

11. Press the **UP** or **DOWN** key to scroll the selected value up or down to the new setting.
12. Repeat steps 10 and 11 until you have changed all the values to the new settings.
13. Press the **ESCAPE** key and the **ENTER** key at the same time to save the new settings and return to the Configuration Menu.

NOTE: Press the ESCAPE key to return to the Configuration Menu without saving the new settings.

Event Log Menu

The Event Log Menu contains the following submenus that show events that are recorded in the controller memory:

- Event Log
- Fuel Events

To enter the Event Log Menu complete the following steps:

1. Place the On/Off switch in the “ON” position.
2. Press the **ENTER** key or the **ESCAPE** key to enter the Main Menu, if necessary.

3. Press the **UP** or **DOWN** key to scroll up or down through the Main Menu to the Event Log Menu.
4. Press the **ENTER** key to enter the Event Log Menu.
5. The Event Log submenu will be displayed.
 - Press the **ENTER** key to enter the Event Log submenu.
 - Press the **UP** or **DOWN** key to scroll up or down to the Fuel Events submenu.
 - Press the **ESCAPE** key to return to the Main Menu.

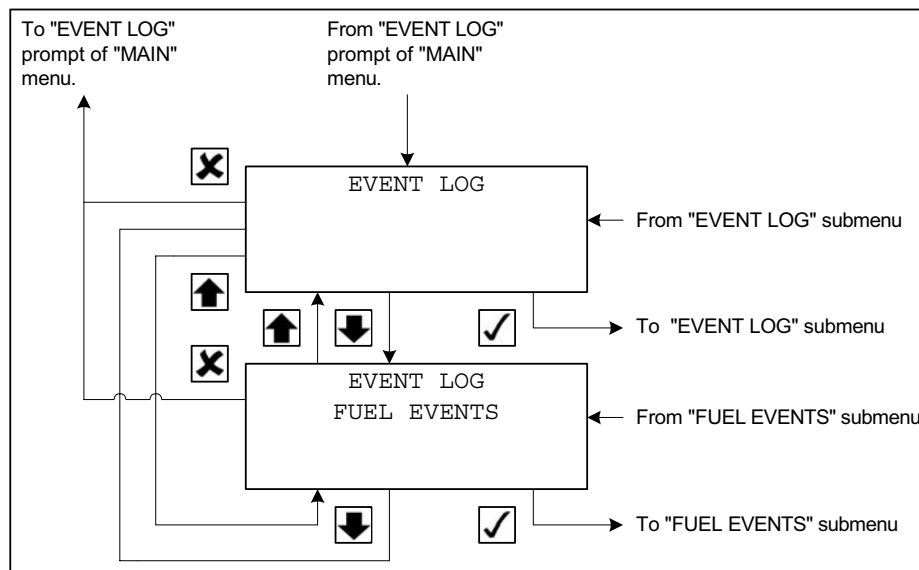

ARA1075

Figure 35: Event Log Menu

Event Log

The Event Log is a list of events that are recorded in the controller memory. Examples of recorded events are a system power up, alarms, and messages. Events are listed in the reverse order of their occurrence. Viewing the event log can be helpful when diagnosing a problem.

NOTE: The Event Log will log 128 events. When full, the controller uses a first in first out overwriting of events.

To enter the Event Log submenu complete the following steps:

1. Place the On/Off switch in the “ON” position.
2. Press the **ENTER** key or the **ESCAPE** key to enter the Main Menu, if necessary.
3. Press the **UP** or **DOWN** key to scroll up or down through the Main Menu to the Event Log Menu.
4. Press the **ENTER** key to enter the Event Log Menu.
5. The Event Log submenu will be displayed.
6. Press the **ENTER** key to enter the Event Log submenu.
7. The Event Log will appear on the display. It shows the most recent event and the date and time of that event.
8. Press the **DOWN** key to scroll down to the next event.
9. Press the **UP** or **DOWN** key to scroll up or down through the event log.
10. Press the **ESCAPE** key to return to the Event Log Menu.

Fuel Events

The Fuel Events is a list of fuel events that are recorded in the controller memory on units equipped with the fuel level sensor option. An example of a recorded event is when fuel is added to the fuel tank. Fuel Events are listed in the reverse order of their occurrence.

NOTE: The Fuel Events will log 128 events. When full, the controller uses a first in first out overwriting of events.

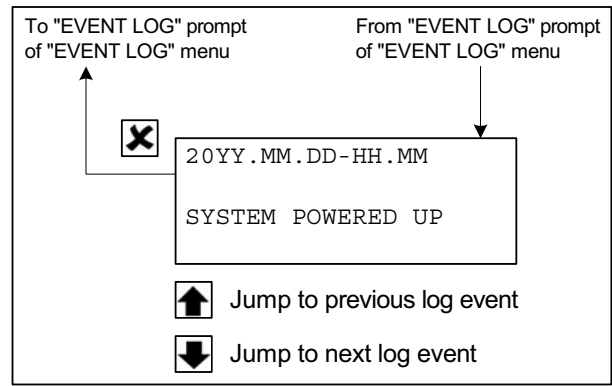

ARA1076

Figure 36: Event Log Submenu

To enter the Fuel Events submenu complete the following steps:

1. Place the On/Off switch in the “ON” position.
2. Press the **ENTER** key or the **ESCAPE** key to enter the Main Menu, if necessary.
3. Press the **UP** or **DOWN** key to scroll up or down through the Main Menu to the Event Log Menu.
4. Press the **ENTER** key to enter the Event Log Menu.

5. The Event Log submenu will be displayed.
6. Press the **UP** or **DOWN** key to scroll up or down to the Fuel Events submenu.
7. Press the **ENTER** key to enter the Fuel Events submenu.
8. The Fuel Events will appear on the display. It shows the most recent fuel event and the date and time of that event.
9. Press the **DOWN** key to scroll down to the next fuel event.
10. Press the **UP** or **DOWN** key to scroll up or down through the fuel events.
11. Press the **ESCAPE** key to return to the Event Log Menu.

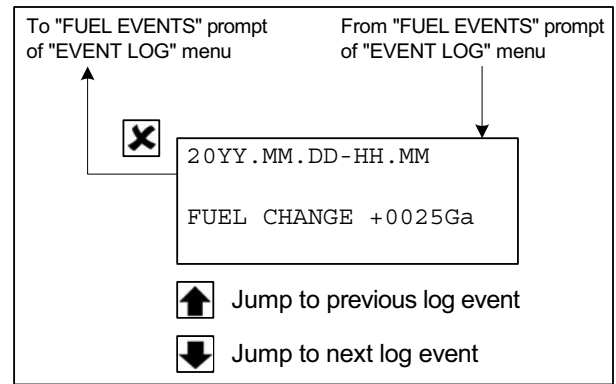

ARA1077

Figure 37: Fuel Events Submenu

LogView and Viewing SG+ Logs

With the release of LogView software version 5.9.2.0 (or later), you can now view SG+ Event logs. The following will outline how to interpret the SG+ log. To understand how to use LogView refer to the Help file found within LogView.

The SG+ log can store up to 128 Event logs. The oldest events will be over written in the log automatically.

With the release of SG+ software 08042300, some changes were made to the description so the log may have different wording based on the software that was in the controller at the time of the logging. The following shows the latest release descriptions.

The latest LogView files can be found on our Web site under Global Marine Solutions Info Central.

NOTE: Logman II PC Rev. 2.4.1 (or later) is required to flashload software or to download the data logger.

Event Description

Data	ID / Code	Description
Alarm	Alarm Code	An alarm is activated, see "Alarm List" on page 52 for alarm descriptions
Message	Message code	A message is activated, see "Message List" on page 55 for message descriptions
Engine	Shutdown alarm	If an alarm is active and entering shutdown state
	Engine running	The engine is running
	Restart engine	Restart sequence started
Pre trip	PTI started	PTI start event
	PTI failed	PTI failed
	PTI OK	PTI completed
Configuration	Factory reset	Factory reset initiated by user
	Clock set	Time and date adjusted
Power	Power off	Time and date for controller power off
	Power on	Time and date for controller power on
Log retrieved	Log retrieved	The event log is retrieved from the unit
Speed	High to low speed - was XXX RPM	RPM above shift point
	Low to high speed - was XXX RPM	RPM below shift point
	Low to high speed RPM below limit	RPM below 1500 RPM
	High to low speed MAGNUM unit detected	A TK MAGNUM unit is detected
	Low to high speed compressor start detected	Reefer unit controller is resetting
	Low to high speed water temperature to high Water temperature XXX	If water temperature is above 5 C below alarm high limit
	Failed to detect speed solenoid	This event is set in the state "LOAD MEAS" if it fails to detect the speed change
Fuel	Positive change from X.X to X.X Ga Change in level; +X.X Ga	Positive fuel change detected
	Negative change from X.X to X.X Ga Change in level; - X.X Ga	Negative fuel change detected
System	Flashload completed OLD: XXX to NEW: XXX	A new version of the application is loaded

Event Log Report
 Container ID: APZJ007063 LogView: 5.9.2.0 SGPlus2LogView.dll: Rev. : 1.1.1.9
 Thermo King SG+ Event Log

Time for transfer : 080826 16:13
 Retriever ID : LogMan II PC v. 2.0.2
 SG+ software version : 080423 revision 00
 SG+ boot loader version : 040108

Thermo King SG+ Event Log

DATE	TIME	DATA
2008/07/21	20:28	POWER.....: Power ON
2008/07/23	14:26	ENGINE.....: Engine running
2008/07/23	15:26	SPEED.....: High to low speed
2008/07/23	16:12	SPEED.....: Low to high speed Compressor start detected
2008/07/23	21:51	POWER.....: Power OFF
2008/07/23	21:51	POWER.....: Power ON
2008/07/24	20:43	ENGINE.....: Engine running
2008/07/25	13:18	FUEL.....: Change in level: 7 Ga
2008/08/10	18:39	SYSTEM.....: Flash load completed Old: 000000 00 New: 080423 00
2008/08/10	18:39	POWER.....: Power ON
2008/08/10	18:39	CONFIGURATION..: Clock set
2008/08/12	14:06	SPEED.....: High to low speed - was 1849 rpm
2008/08/12	15:13	SPEED.....: Low to high speed - was 1505 rpm
2008/08/16	14:30	SPEED.....: Low to high speed - water/temperature too high Water temperature 102.6 C
2008/08/16	14:31	MESSAGE.....: Water temperature sensor failure (#113)
2008/08/20	15:18	SPEED.....: Low to high speed - was 1538 rpm Compressor start detected
2008/08/21	04:18	FUEL.....: Positive change from 41.3 to 54.3 Ga Change in level: +13.0 Ga
2008/08/24	05:18	FUEL.....: Negative change from 54.2 to 35.2 Ga Change in level: -19.0 Ga
2008/08/26	16:13	LOG RETRIEVED.: Log retrieved

Latest DLL file revision

Old fuel event description prior to 080423 software

Software update

New fuel event description

Figure 38: Example of SG+ Log

ARA1663

Electrical Maintenance

Battery

CAUTION: Place the Unit On/Off switch in the “OFF” position, Before connecting or disconnecting the unit battery,

Inspect and clean the battery terminals, check the electrolyte level during scheduled maintenance inspections. The minimum specific gravity should be 1.235. Add distilled water as necessary to maintain the proper water level.

A dead or low battery can be the cause of an ammeter indicating discharge due to lack of initial excitation of the alternator.

NOTE: If the battery was discharged enough that a boost was needed, the alternator may not recharge the battery. This is because there may not be adequate current to excite the alternator field.

Relays

All the relays are 12 Vdc relays. The relays on the microprocessor PC board are interchangeable. The relays mounted on the inside of the control box are interchangeable. The relays on the microprocessor PC board are not interchangeable with the relays mounted on the inside of the control box. Test a relay by interchanging it with a known good relay.

Fuel Pull Relay

The fuel pull relay (RL1) is located on the PC board. It supplies power to the fuel solenoid pull-in coil through the 8DP circuit. If the fuel pull relay fails in the closed position, the fuel solenoid pull-in coil will be damaged. If the relay fails in the open position, the fuel solenoid will not energize. The RL1 LED on the PC board will light up when the fuel pull relay is energized.

Fuel Hold Relay

The fuel hold relay (RL2) is located on the PC board. It supplies power to the fuel solenoid hold-in coil through the 8D circuit. If the fuel hold relay fails in the closed position, the unit would operate continuously and not stop for a protection shutdown. If the relay fails in the open position, the fuel solenoid will energize momentarily but

will not stay energized. The RL2 LED on the PC board will light up when the fuel hold relay is energized.

Speed (Throttle) Solenoid Relay

The speed solenoid relay (RL3) is used on units equipped with the EcoPower option and is located on the PC board. It supplies power to the speed solenoid through the 7D circuit. If the speed solenoid relay fails in the closed position, the engine would only run in high speed. If the relay fails in the open position, the engine would only run in low speed. The RL3 LED on the PC board will light up when the speed solenoid relay is energized.

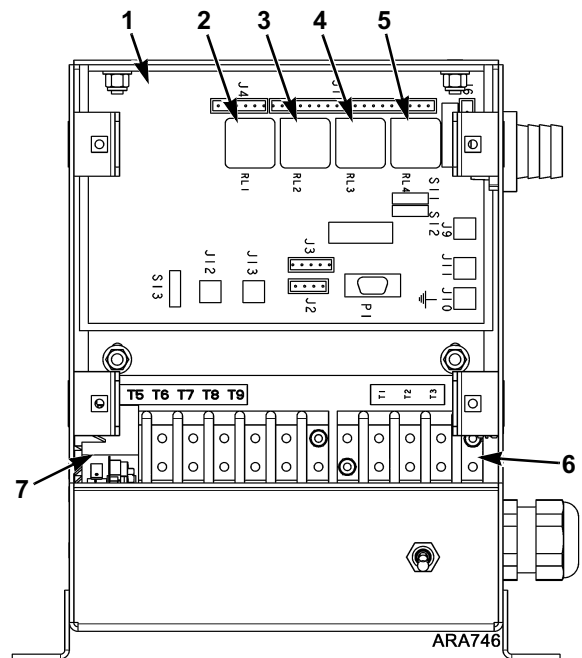

1.	PC Board
2.	Fuel Pull Relay (RL1)
3.	Fuel Hold Relay (RL2)
4.	Speed Solenoid Relay (EcoPower Option Only) Spare Relay (If Installed On Units Without EcoPower Option)
5.	Spare Relay (If Installed)
6.	Terminal Boards
7.	Start and Preheat Relays (RL5 and RL6)

Figure 39: Components Inside Control Box

Start Relay

The start relay (RL5) is mounted on the inside of the control box. It is energized by the controller after proper preheat time has occurred. When this relay energizes, the starter solenoid receives power and the engine cranks. If the start relay fails in the open position, the engine would not crank. If the relay failed in the closed position, the starter would continue to crank after the unit started. The RL5 LED on the PC board will light up when the fuel pull relay is energized.

Preheat Relay

The preheat relay (PHR) is mounted on the inside of the control box. It supplies power to the air heater. If the preheat relay fails in the open position, the air heater would not preheat and the engine may not start, resulting in the cranking time limit being exceeded. If the preheat relay fails in the closed position, the air heater will remain energized. The RL6 LED on the PC board will light up when the fuel pull relay is energized.

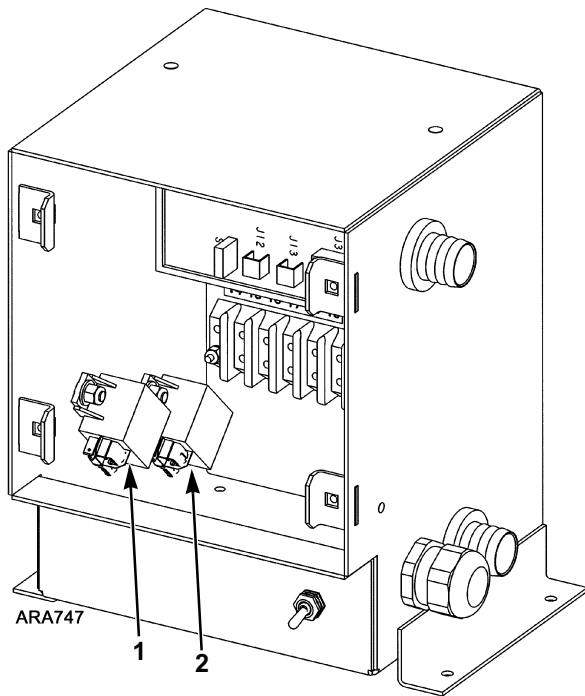

1.	Start Relay (RL5)
2.	Preheat Relay (RL6)

Figure 40: Relay Locations

Unit Wiring

Inspect the unit wiring and wire harnesses during scheduled maintenance inspections for loose, chafed or broken wires. This will protect against unit malfunctions due to open or short circuits.

12 Vdc Charging System

Battery charging current is supplied by a transformer and rectifier utilizing current from the ac alternator. The battery charging circuit provides current to the battery until the proper charge level is attained (13.1 to 14.6 volts).

The alternator exciter field is energized by the SG+ controller. This initiates battery charging approximately 15 seconds after engine start-up.

NOTE: *The engine must run for approximately 15 seconds before the battery charging circuit is energized. When the Delayed Cold Start feature is set to ON, the controller shows “dDELAY / AC” screen and the alternator output remains off until the engine temperature increases to 32 C (90 F).*

NOTE: *The alternator exciter field coil (F1/F2) for the SG+ and the μ PG are different. The SG+ resistance reading is 13.9 ohms and the μ PG is 2.3 ohms. In the photo below the μ PG is on the left and SG+ is on the right. The μ PG will have the external lead shown on the top of the coils. See Service Bulletin C087 for more information.*



1.	External Lead on Top of μ PG Coil
----	---------------------------------------

Figure 41: Alternator Exciter Field Coils

Air Heater

The air heater heats the intake air to help the engine start in cold weather. The air heater is energized when the controller initiates a unit start-up (unit On/Off switch in the “ON” position).

The air heater is mounted on the open end of the intake manifold. Check the resistance of the air intake heater with an ohmmeter. Place the ohmmeter leads between the M6 terminal on the front of the heater and the screw on the back of the heater (or the heater case). The resistance should be 0.1 to 0.2 ohms.

Check the current draw of the heater with a clamp-on ammeter while the engine is cranking. Connect ammeter at the H wire near the M6 terminal on the front of the heater. The current draw should be approximately 89 amps at 12.5 volts. The heater is probably defective if the current draw is less than 60 amps or more than 100 amps.

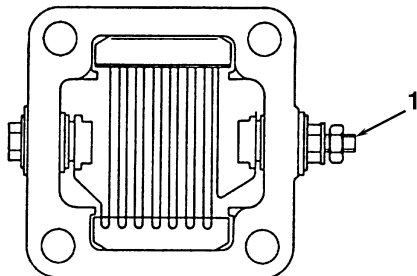

AXA0336

1.	M6 Terminal
----	-------------

Figure 42: Air Heater

2. Continuity tester should indicate a complete circuit between the terminal and ground.
3. Start the engine. Tester should show an open circuit between each terminal and ground. Repair consists of replacing the switch.

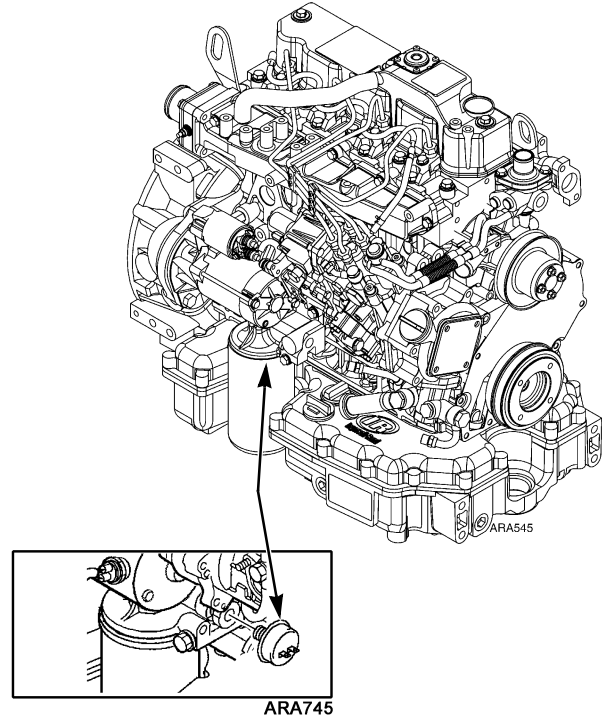

Figure 43: Engine Oil Pressure Switch

Engine Low Oil Pressure Switch

Engine oil pressure should rise immediately on starting. This causes the oil pressure switch to open. If the oil pressure drops below 117 ± 21 kPa (1.17 ± 0.21 bar) (17 ± 3 psi), the switch will close. This causes the controller to stop the engine. A continuity tester is needed to check the oil pressure switch. To check switch continuity complete the following steps:

1. Remove wire OPS from the switch.

Oil Level Sensor

If the engine oil level drops below the actuation level, the low oil level sensor (OLS) switch will close. This will cause the controller to stop the engine. The oil level switch is located in the oil pan on the front side of the engine near the oil filter.

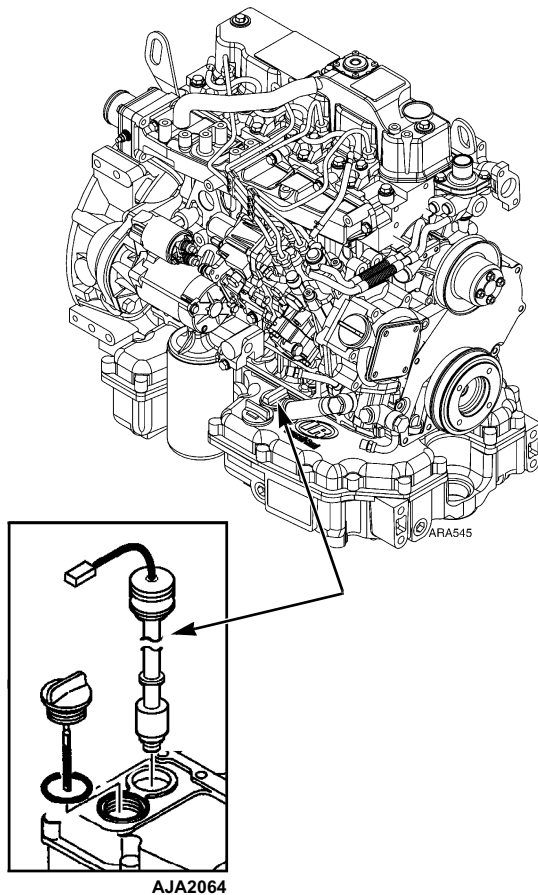

Figure 44: Oil Level Sensor

Switch Test

1. Turn the unit ON/OFF switch to the “OFF” position.
2. Disconnect the switch wires from the main wire harness.
3. Connect a continuity tester to the two sockets in the low oil level switch wire connector.
4. Check the oil level with the dipstick. Make sure that it is between the low mark and the full mark. Add oil if necessary.

5. The switch should be open and there should be no continuity between the switch wires. (When the oil level is between the low mark and the full mark on the dipstick).

Bench test the switch if there is continuity between the OLS and CH wires and there are no short circuits in the wires.

Switch Removal and Installation

1. Disconnect the switch wires from the main wire harness before removing the switch.
2. Remove the screw-in style switch by carefully turning it out of the oil pan with a wrench.
3. To install the screw-in style switch, first lubricate the O-ring on the switch with engine oil. Then screw the switch into the oil pan.
4. Connect the switch wires to the main wire harness after installing it.

Bench Test

1. Disconnect the switch wires from the main wire harness. Remove the switch from the oil pan.
2. Use a small container partially filled with engine oil to check the float. Make sure that it floats in engine oil and that it slides freely between the upper and lower stops.
3. Slide the float up to the upper stop. Check the continuity through the switch (between OLS and CH wires). The switch should be open.
4. Slide the float down to the lower stop. Check the continuity through the switch. The switch should be closed.
5. Replace the switch if the float sinks or does not slide freely, or if the switch does not open and close properly.

Coolant Temperature Sensor

The coolant temperature sensor is connected to the engine coolant system near the water pump. It uses coolant temperature to present a variable resistance to the controller. Test the coolant temperature sensor if the controller records Alarm Code 18 or 41 and the coolant temperature appears to be normal.

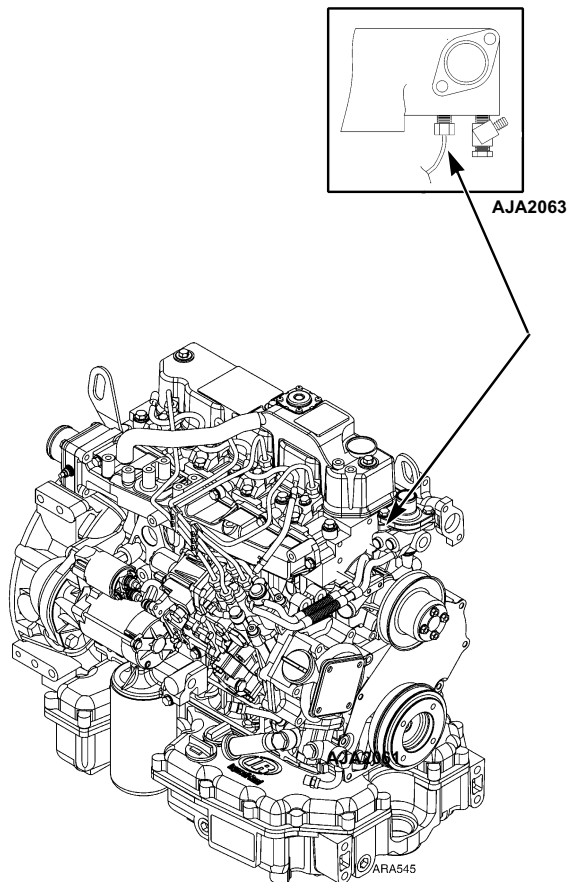

Figure 45: Coolant Temperature Sensor

Sensor Test

1. Turn the unit On/Off switch to the “OFF” position.
2. Disconnect the sensor at the plug next to the sensor.
3. Turn the unit On/Off switch “ON”.

NOTE: Polarity must be considered when connecting temperature sensors. If a sensor is connected backwards, the display will show a reading below -40 C (-40 F) or above 130 C (266 F) and record Alarm Code 101. Consult the unit wiring diagram or schematic for correct connections.

4. Enter the Analog Inputs submenu of the Data Menu and scroll to the engine temperature screen. If the display shows a reading below -40 C (-40 F) or above 130 C (266 F) check the sensor wiring, the sensor polarity, and test the controller.
5. Using a digital voltmeter, check the voltage at the sensor plug connected to the controller. The voltage must be from 2.33 to 3.98 Vdc.
 - a. If the voltage is correct, disassemble and inspect the coolant sensor plug. Replace the sensor if there are no broken wires or pushed pins in the plug.
 - b. If the voltage is incorrect, recheck the voltage at the same circuit at pins 13 (positive) and 14 (negative) of the J1 connector on the microprocessor PC board. The voltage must be from 2.33 to 3.98 Vdc. If the voltage is correct at the controller, the problem is in the wiring. Continuity test the wire harness circuits. If the voltage is incorrect again, the controller is defective. Test the controller.

Coolant Level Detector Sensor

The coolant level detector sensor is a stainless steel probe immersed in the coolant. It is located on the side of the radiator. It does not fail or wear out, but may fail to conduct current if it is dirty.

The sensor will no longer conduct current to return a signal to the controller if the coolant level drops too low in the radiator. After 30 seconds, the controller will record Message Code 108. Test the coolant level sensor if the controller records Message Code 108 and the radiator is full of coolant.

 **WARNING: DO NOT remove the radiator cap from the radiator fill neck when the engine coolant is hot.**

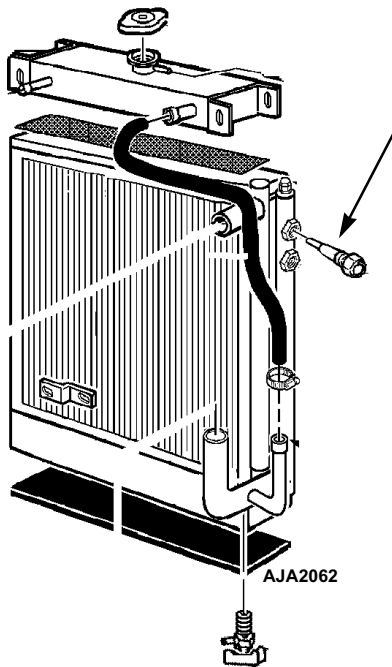

Figure 46: Coolant Level Detector Sensor

Sensor Test

1. Ground the sensor to chassis ground with a jumper wire.
2. Attempt to clear Message Code 108 from the controller by acknowledging it.
 - Check to see if Message Code 108 clears by turning the On/Off switch OFF and then back ON. Wait 30 seconds to see if Message Code 108 reappears.
 - If Message Code 108 reappears, test the wire harness for continuity. Also test the controller.

Flywheel Sensor

The flywheel sensor is in the engine bell housing adjacent to, but not touching, the flywheel (backed off 1/2 turn).

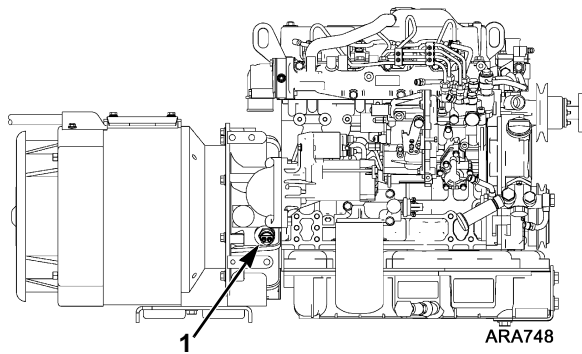

1.	Flywheel Sensor
----	-----------------

Figure 47: Flywheel Sensor Location

The flywheel sensor is a device containing an inductance coil and magnet. When the magnetic field is distorted by the passing ring gear teeth, the inductance coil generates an ac electrical signal. The signal has a voltage and frequency variation proportional to the engine rpm.

The timing of the starter disengagement can be precisely controlled by monitoring the frequency of this signal with the starter disconnect module.

The starter may not disengage or engage properly, if the flywheel sensor fails.

Testing the Flywheel Sensor

Equipment required:

- AC voltmeter capable of reading up to 10 volts
- Ohmmeter
- SG unit for installing the sensor in the threaded hole in the flywheel housing.

To test the flywheel sensor:

1. Install the flywheel sensor into the threaded hole in the flywheel housing of an SG unit until it contacts the ring gear.
2. Back out the sensor 1/2 turn and tighten the locknut.
3. Disconnect wires FS1 and FS2 from the sensor.

4. Start and operate the unit.
5. Check the ac voltage output across the sensor terminals. Use a meter with a high ohms per volt internal resistance. A Simpson 260, Fluke digital or any good VOM will work. However, an automotive type meter may not give an accurate reading because the meter may load the circuit heavily and cause the voltage level to appear lower than actual. The output voltage should be 1.5 to 2.0 Vac.

NOTE: If the voltage is slightly off, the voltage may be increased by turning the sensor in more. The voltage may be lowered by turning the sensor out more.

6. Reconnect FS1 and FS2 wires on flywheel sensor.

The sensor may be considered good if the flywheel sensor passes the above test. If a unit is not available, an alternate but less reliable test may be performed as follows:

1. Disconnect the sensor from all wires.
2. Measure the resistance across the terminals. The resistance should be 250 to 300 ohms across the terminals.
3. Measure the resistance from each terminal to the aluminum case. There should be no continuity from each terminal to the case.

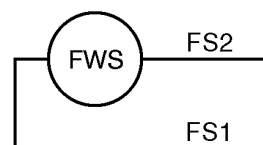
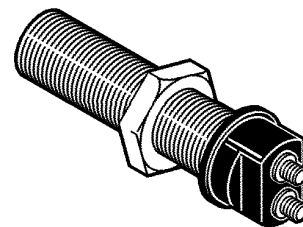

AXA0288

Figure 48: Flywheel Sensor with Wiring and Schematic Symbols

Engine Maintenance

EMI 3000

EMI 3000 is an extended maintenance interval package. It is standard equipment on these units. The EMI 3000 package consists of the following key components:

- New EMI 3000-Hour Fuel Filter (black with gold lettering)
- New EMI 3000-Hour Dual Element Oil Filter (black with gold lettering)
- API Rating CI-4 Mineral Oil (ACEA Rating E3 for Europe)
- Five Year or 12,000 Hour ELC (Extended Life Coolant).

The EMI package allows standard maintenance intervals to be extended to 3,000 hours, or 2 years, whichever occurs first.

NOTE: Units equipped with the EMI 3000 package do require regular inspection in accordance with Thermo King's maintenance recommendations.

NOTE: The new EMI 3000 oil filters and new cyclonic dry air cleaners are NOT interchangeable with the oil filters and air cleaners previously used in these units.

Engine Lubrication System

The TK486 family of engines use a pressure lubrication system. Refer to the TK482 and TK486 Engine Overhaul Manual TK 50136 for a detailed description of the engine lubrication system.

Engine Oil Change

The engine oil should be changed according to the Maintenance Inspection Schedule. Drain the oil only when the engine is hot to ensure that all the oil drains out. When changing oil, keep unit and trailer level so all the oil can flow from the oil pan. It is important to get as much of the oil out as possible because most of the dirt particles are contained in the last few quarts of oil that drain out of the pan. Refill the pan with 12.3 litres (13 quarts) and check the dipstick level. Run the unit, and then recheck the oil level. The engine oil level should be at the FULL mark with the dipstick turned (threaded) into the oil pan. Never overfill. See Specifications Chapter for the correct type of oil.

Oil Filter Change

The oil filter should be changed along with the engine oil. Use a genuine Thermo King extended maintenance oil filter.

1. Remove the filter.
2. Apply oil to the rubber ring of the new filter and install the filter.
3. Tighten the filter until the rubber ring makes contact, then tighten 1/2 turn more.
4. Start the unit and check for leaks.

Low Oil Pressure

Oil pressure is affected by oil temperature, oil viscosity, and engine speed. Low oil pressure can usually be traced to the lack of oil, a faulty oil

pressure regulating valve, or worn bearings. Low oil pressure is not normally caused by a faulty oil pump. Use the following “Low Oil Pressure Flow Chart” to help diagnose low oil pressure.

Low Oil Pressure Flow Chart

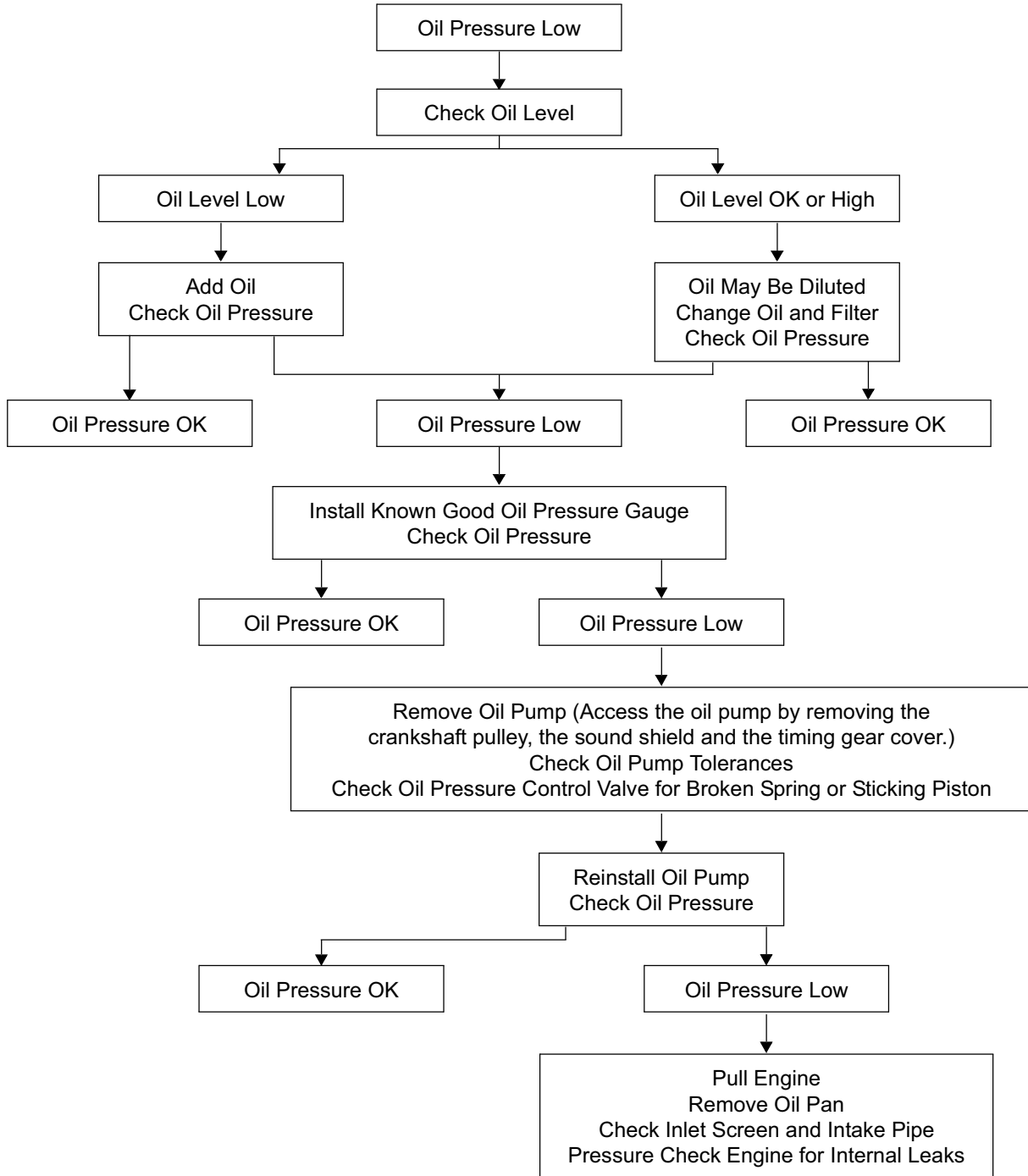

Crankcase Breather

Gases formed in the crankcase are directed to the intake manifold. Harmful vapors that would otherwise collect in the crankcase and contaminate the oil, or escape to the outside, are drawn back into the engine and burned.

The crankcase breather is located in the valve cover. A restrictor is cast into the fitting for the breather hose on the intake manifold. The restrictor limits the flow of gases from the crankcase to the intake manifold and keeps the crankcase pressure from getting too low in vacuum. A breather hose connects the crankcase breather to the intake manifold.

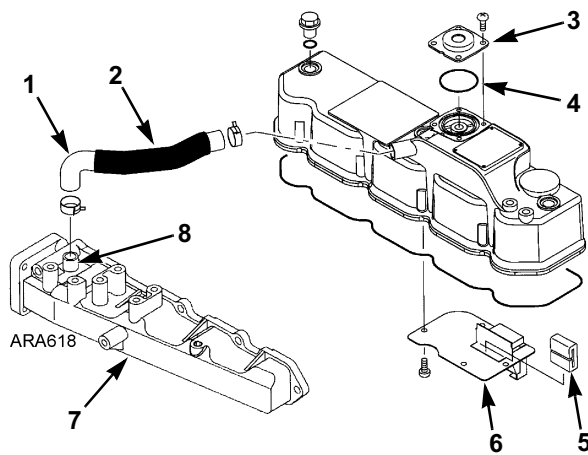

1.	Breather Hose	5.	Baffle Breather
2.	Insulation	6.	Baffle Plate
3.	Breather Cover	7.	Intake Manifold
4.	O-Ring	8.	Restrictor Location

Figure 49: Crankcase Breather

Normal crankcase pressures with a new air cleaner are 2 to 12 in. (50 to 300 mm) H₂O of vacuum. The vacuum will increase as the air cleaner gets dirty and becomes more restrictive. Check the air restriction indicator before checking the crankcase pressure. Replace the air cleaner if the reading on the air restriction indicator exceeds 20 in. (508 mm) H₂O of vacuum. A dirty air cleaner may cause excessive vacuum, leading to oil carry over and high oil consumption.

The crankcase breather and the breather hose should be inspected when the air cleaner element is replaced to make sure they are not plugged or damaged. Inspect the insulation to make sure it is in place and undamaged. The insulation is used to prevent freezing in cold weather.

The following items can effect the crankcase pressure readings.

Crankcase Pressure Effect	Typical Cause
Increase	Piston Rings Stuck or Worn
Increase	Breather Hose or Restrictor Plugged with Dirt or Ice
Decrease	Air Cleaner Dirty or Plugged

Cyclonic Dry Air Cleaner

The cyclonic dry air cleaner is a dry element air cleaner used on units manufactured after 11/15/02. It filters all of the air entering the engine. Replace the dry air cleaner element when the air restriction indicator reads 25 in. of vacuum, or at 2 years, whichever comes first.

NOTE: The dust ejector must point down when installed.

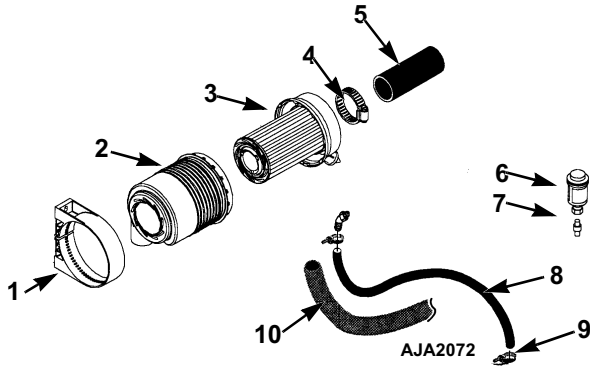

1.	Air Cleaner Clamp
2.	Dry Air Cleaner
3.	Air Cleaner Element
4.	Hose Clamp
5.	Air Cleaner Hose
6.	Air Restriction Indicator
7.	Indicator Fitting
8.	Breather Hose
9.	Band wrap
10.	Insulation Hose

Figure 50: Cyclonic Dry Air Cleaner

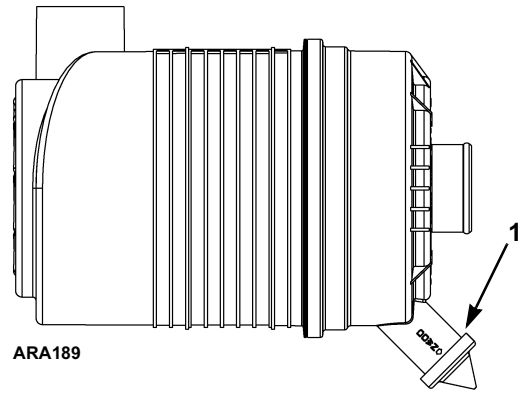

1. Dust Ejector Must Point Down When Installed

Figure 51: Cyclonic Dry Air Cleaner

Air Restriction Indicator

An air restriction indicator is installed in the air intake manifold on units with a dry air cleaner. Excessive restriction of the air intake system reduces the flow of air to the engine. This affects horsepower output, fuel consumption and engine life.

Periodically inspect the restriction indicator to assure the air filter is not restricted. Service the air filter when the yellow diaphragm indicates 25 in. of vacuum. Press the reset button on the bottom of the restriction indicator after servicing the air filter.

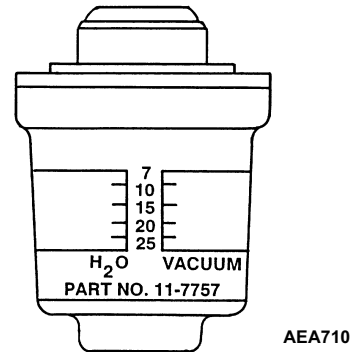

Figure 52: Air Restriction Indicator

Engine Cooling System

The engine uses a closed, circulating type, pressurized cooling system. Correct engine temperatures are controlled and maintained by a radiator, fan and thermostat. The coolant is circulated through the system by a belt-driven centrifugal pump. The pump draws the coolant from the side of the radiator. It circulates the coolant through the cylinder block and head and back to the radiator. A thermostat is mounted in the water outlet from the cylinder head to the radiator. It automatically maintains coolant temperature within the specified temperature range.

All water-cooled engines are shipped from the factory with a 50% permanent type antifreeze concentrate and 50% water mixture in the engine cooling system. Benefits include:

1. Prevents freezing down to -34 C (-30 F).
2. Retards rust and mineral scale that can cause the engine to overheat.
3. Retards corrosion (acid) that can an attack accumulator tank, water tubes, radiator and engine block plug.
4. Provides lubrication for the water pump seal.

ELC (Extended Life Coolant)

ELC has been phased into all container units equipped with engines from the TK486 engine family. A nameplate on the coolant expansion tank identifies units with ELC.

NOTE: The new engine coolant, Texaco Extended Life Coolant, is RED in color instead of the current GREEN or BLUE-GREEN colored coolants.

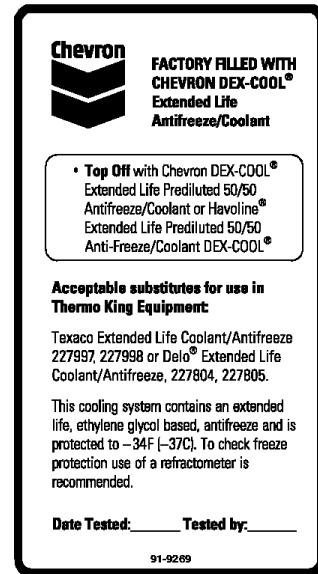

AJA1947

Figure 53: ELC Nameplate Located On Expansion Tank

The following are the Extended Life Coolants currently approved by Thermo King for use in ELC units for five years or 12,000 hours:

- Chevron Dex-Cool
- Texaco ELC (nitrite free)
- Havoline Dex-Cool (with nitrates)
- Havoline Dex-Cool (nitrite free)
- Shell Dexcool
- Shell Rotella
- Havoline XLC (Europe)
- Saturn/General Motors Dex-Cool
- Caterpillar ELC
- Detroit Diesel POWERCOOL Plus.



CAUTION: Do not add “GREEN” or “BLUE-GREEN” conventional coolant to cooling systems using “RED” Extended Life Coolant, except in an emergency. If conventional coolant is added to Extended Life Coolant, the coolant must be changed after 2 years instead of 5 years.

NOTE: The use of 50/50 percent pre-mixed Extended Life Coolant (ELC) is recommended to assure that de-ionized water is being used. If 100 percent full strength concentrate is used, de-ionized or distilled water is recommended over tap water to insure the integrity of the cooling system is maintained.

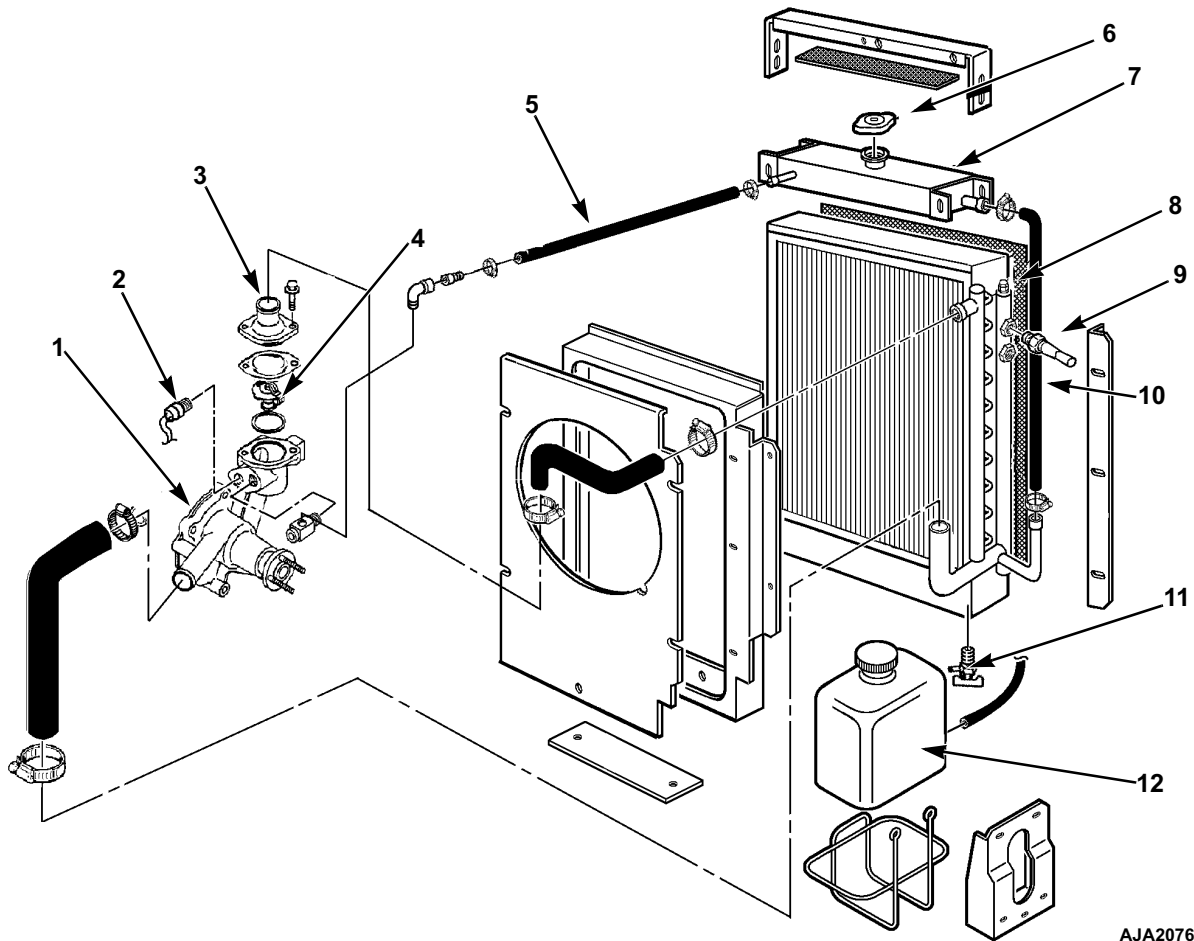

AJA2076

1.	Water Pump	7.	Expansion Tank
2.	Water Temperature Sensor	8.	Vent Fitting for Bleeding Air from Radiator (recently built models)
3.	Engine Thermostat Housing	9.	Water Level Sensor
4.	Engine Thermostat	10.	Radiator
5.	Vent Hose	11.	Drain Cock, Radiator
6.	Radiator Cap	12.	Overflow Tank

Figure 54: SGCO Engine Cooling System

Antifreeze Maintenance Procedure

Regular inspection is required to verify the condition of the antifreeze. Inhibitors become worn out and must be replaced by changing the antifreeze. The inhibitors in Extended Life Coolant (ELC) antifreeze (red color) extend change intervals to 5 years or 12,000 hours.

Do not mix green or blue-green engine coolant with ELC (red) engine coolant. See “ELC (Extended Life Coolant)” on page 91 for more information about ELC.

ELC coolants are available in 100 percent full strength concentrate or (pre-mixed) 50/50 percent mixture. Thermo King recommends the use of 50/50 percent pre-mixed ELC antifreeze to assure that de-ionized water is used. 100 percent concentrate extended life coolant must be mixed with de-ionized or distilled water (NOT tap water) to ensure cooling system integrity.

NOTE: See *Specifications chapter for coolant capacity and correct type of antifreeze for your unit.*

When changing antifreeze, drain, flush and replace the total antifreeze mixture to maintain total cooling system protection. To prevent mineral scale, use water with a total hardness under 170 ppm. If the total water hardness is over 170 ppm, soften the water or use distilled water. The water must also be de-mineralized, de-ionized or distilled if it does not meet the following requirements: chlorides concentration under 40 ppm, sulfates concentration under 100 ppm and total dissolved solids under 340 ppm.

The factory recommends the use of a 50/50 antifreeze/water mixture in all units. Even if they are not exposed to freezing temperatures. A 50/50 antifreeze mixture will provide the required corrosion protection and lubrication for the water pump.

Checking the Antifreeze



WARNING: Avoid direct contact with hot coolant.

Check the solution concentration by using a temperature compensated antifreeze hydrometer or a refractometer designed for testing antifreeze. A refractometer works with both ELC and conventional antifreeze. Maintain a minimum of 50 percent permanent type antifreeze concentrate and 50 percent water solution to provide protection to -34 C (-30 F). Do not mix antifreeze stronger than 68 percent permanent type coolant concentrate and 32 percent water for use in extreme temperatures.

Changing the Antifreeze

1. Operate the engine until it is up to operating temperature. Then stop the unit.
2. Open the engine block drain and completely drain coolant. Observe coolant color. If the coolant is dirty, proceed with a, b, and c. Otherwise go to step 3.
 - a. Pour clear water into radiator and allow it to drain out of the block until it is clear.
 - b. Close the block drain and install a commercially available radiator and block flushing agent. Operate the unit in accordance with instructions of the flushing agent manufacturer.
 - c. Open the engine block drain to drain water and flushing solution.
3. Pour clear water into the radiator. Allow it to drain out of the block until it is clear.
4. Inspect all the hoses for deterioration and the hose clamps for tightness. Replace if necessary.
5. Loosen the water pump belt. Check the water pump bearing for looseness and retighten the belt (See “Belt Tension Adjustment and Belt Replacement” in this chapter).
6. Inspect the radiator cap. Replace the cap if the gasket shows any signs of deterioration.

7. Prepare 8 liters (2 gallons) of 50/50 percent antifreeze/water mixture. Do not add antifreeze and then water to the unit. This procedure may not give a true 50/50 mixture because the exact cooling system capacity may not be known.

NOTE: *Thermo King recommends the use of 50/50 percent pre-mixed ELC antifreeze to assure that de-ionized water is used. 100 percent concentrate extended life coolant must be mixed with de-ionized or distilled water (NOT tap water) to ensure cooling system integrity.*

8. Close all drains. On recently built units, also open vent fitting on top of the inlet header on the radiator. Refill the radiator with the 50/50 antifreeze mixture. Make sure all air is bled from the cooling system.

NOTE: *Make certain all air is purged from the cooling system, especially on centermount and sidemount units. Recently built units include a special vent fitting on the top of the inlet header on the radiator. Open this fitting to bleed air from the cooling system when refilling the radiator with coolant.*

Bleeding Air from the Cooling System

A jiggle pin thermostat prevents air from being trapped in the engine block. This should make it unnecessary to bleed the air out of the engine. Normally approximately 8.5 liters (9 quarts) of coolant will drain from the cooling system. If only 4 liters (4 quarts) of coolant fill the cooling system after it has been drained, air has been trapped in the block. Bleed the air out of the block using the following procedure:

CAUTION: *If you suspect that air is trapped in block, do not start the engine without bleeding the air out of the block.*

NOTE: *If an engine operates with air trapped in the block, engine damage could occur. The high water temperature switch may not protect an engine that has air trapped in the block.*

1. Remove the plug from the front end of the water pump before pouring coolant into the cooling system. Recently built units also

include a special vent fitting on the top of the inlet header on the radiator. Also open this fitting to bleed air from the radiator.

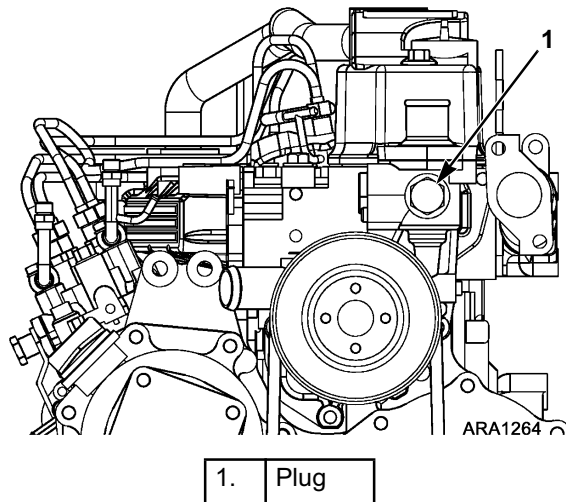

Figure 55: Remove Plug from Water Pump

2. Slowly pour coolant into the system until coolant comes out of the plug fitting.
3. Reinstall the plug on the water pump.
4. Pour coolant into the system until it appears to be full.
5. Make sure that the amount of coolant that goes back into the system is approximately equal to the amount of coolant that was drained from the system.
6. Start the engine. Monitor the engine coolant temperature with the controller. When the temperature reaches 66 C (150 F), shut the engine off for 2 minutes. This allows time for the thermostat to heat soak and open fully, ensuring that any remaining air will be purged out of the engine block when the engine is restarted.
7. Restart the engine and run it for a minute. Then stop the unit.
8. Check the coolant level and add coolant if necessary.
9. Repeat steps 7 and 8 until the coolant level stabilizes.
10. Close the vent fitting on the top of the inlet header on the radiator (recently built units only).

Engine Thermostat

TK486V engines use a 71 C (160 F) thermostat.

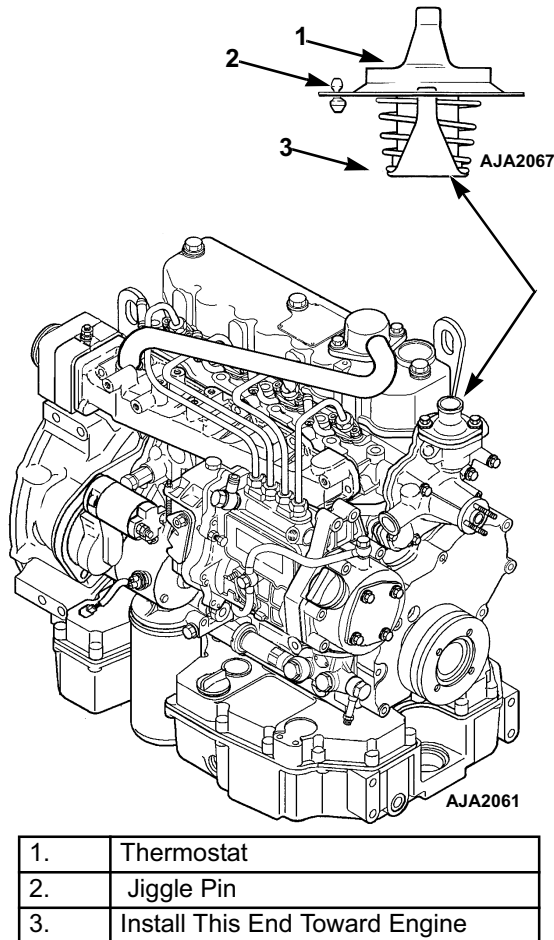

Figure 56: Engine Thermostat

Engine Fuel System

TK486V engines use a mono-plunger and distributor injection pump.

The components of a typical fuel system include:

1. Fuel tank
2. Fuel strainer (inlet to transfer pump)
3. Fuel filter
4. Water separator
5. Hand fuel pump
6. Transfer pump
7. Injection pump
8. Injection nozzles

The hand fuel pump is used to manually draw fuel from the tank up to the transfer pump if the unit should run out of fuel.

The transfer pump draws fuel from the fuel tank through a fuel inlet strainer at the inlet to the transfer pump. The transfer pump then delivers fuel through the fuel heater to the fuel filter/water separator. Filtered fuel passes through a line from the outlet fitting on the filter base to the injection pump.

The injection pump forces the fuel, at a very high pressure, through the injection nozzles. The injection nozzles atomize the fuel as it is injected directly into the combustion chambers.

Injection pump leakage, injection nozzle overflow and excess fuel from the fuel filter assembly return to the fuel tank through the return lines.

Maintenance

The fuel system is relatively trouble-free and if correctly maintained will usually not require major service repairs between engine overhauls.

Contamination is the most common cause of fuel system problems. Therefore, to ensure best operating results, the fuel must be clean and fuel tanks must be free of contaminants. The single element fuel filter/water separator must be changed according to the Service Guide in the Introduction of this manual or the Maintenance Inspection Schedule on the unit.

NOTE: The injection nozzles must be tested (and repaired if necessary) at least every 3,000 hours in accordance with EPA 40 CFR Part 89.

Normal conditions are considered to be the use of clean high quality fuel, no used oil blending, and regular maintenance of the fuel system according to the Maintenance Inspection Schedule. Refer to the TK482 and TK486 Overhaul Manual TK 50136 for injection nozzle testing and repair procedures.

Whenever the fuel system is opened, take the following precautions to prevent dirt from entering the system:

- Cap all fuel lines.
- Work in as clean of an area as possible.

- Complete the work in the shortest possible time.

Any major injection pump or nozzle repairs should be done by a quality diesel injection service shop. The necessary service equipment and facilities are not found in most engine rebuild shops because of the large investment required.

The following procedures can be done under field conditions:

- Bleeding air from the fuel system
- Fuel tank and filter system maintenance

- Prime pump (hand) replacement or repair*
- Transfer pump replacement or repair*
- Injection line replacement*
- Engine speed adjustments
- Pump timing
- Nozzle spray pattern testing and adjustment*
- Minor rebuilding of nozzles*
- Trochoid feed pump replacement

*These procedures are covered in the TK482 and TK486 Overhaul Manual, TK 50136.

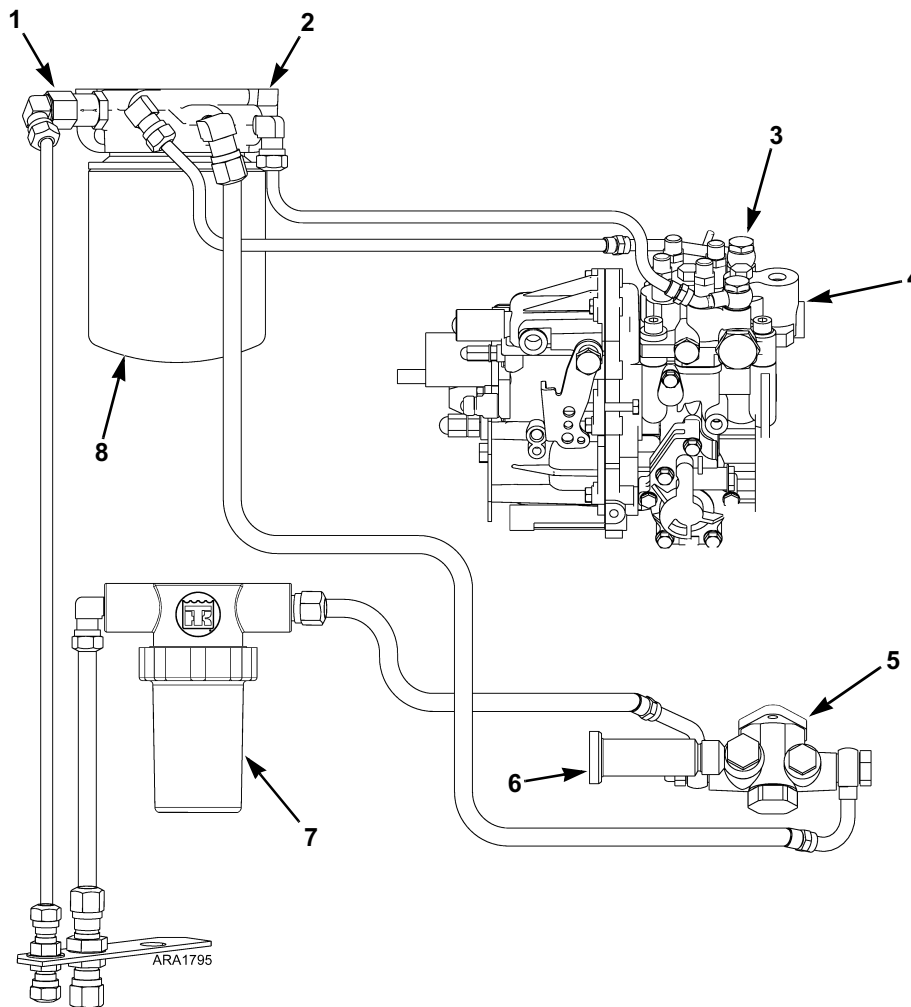

1.	Check Valve (Keeps air from entering fuel system when engine is not running.)	5.	Fuel Transfer Pump
2.	Filter Head	6.	Priming Pump
3.	Bleed Screw	7.	Fuel Strainer
4.	Mono-plunger and Distributor Injection Pump	8.	Fuel Filter/Water Separator

Figure 57: Fuel System

Fuel Return Line Replacement

The fuel return lines (hoses) and end cap on the fuel injection nozzles should be changed every 10,000 engine operating hours. The return line kit (P/N 10-373) contains new return lines, clamps, an end cap, and a decal like the one shown below. This decal is was added to production units in January of 2005. The decal is located near the unit serial plate. The date and engine hours must be entered on the decal when the fuel return lines are changed.

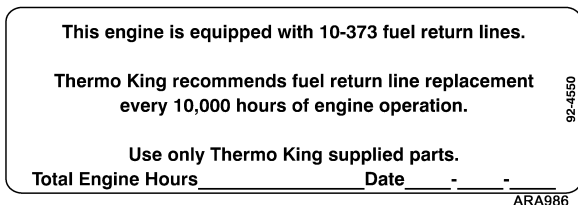
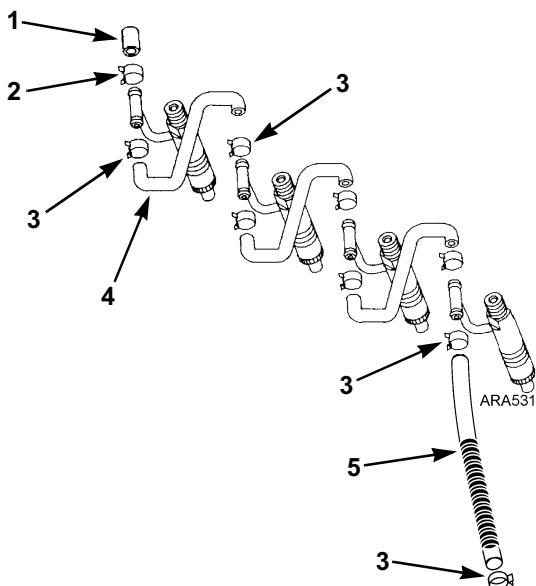

Figure 58: Fuel Return Line Replacement Decal

Use the following procedure to replace the fuel return lines and end cap.

1. Remove the clamps, the end cap, the short fuel return lines between the injection nozzles, and the long fuel return line from the injection nozzle to the banjo fitting on the injection pump.



1.	End Cap	4.	Short Fuel Return Lines
2.	Larger Clamp	5.	Long Fuel Return Lines
3.	Smaller Clamps		

Figure 59: Fuel Return Line Replacement

2. Discard the old clamps, end cap, and fuel return lines.
3. Install the end cap and clamp. Note that the end cap has a larger OD than the other hoses and requires the larger clamp.
4. Install the fuel return lines and clamps. It may be necessary to adjust the banjo fitting slightly to obtain the straightest routing for the long return line.
5. Be sure all the fittings are tight and check for leaks.
6. Write the date and engine hours on the decal.

Bleeding the Fuel System

The fuel system must have the air bled out if any of the following circumstances occur:

- If the fuel tank becomes empty
- If repairs are made to the fuel system
- If air gets into the system for any other reason.

NOTE: MAKE SURE the fuel tank vent is kept open. If the vent becomes clogged, a partial vacuum develops in the tank, and this increases the tendency for air to enter the system.

To bleed air from the fuel system:

1. Loosen the bleed screw on the injection pump about one turn.

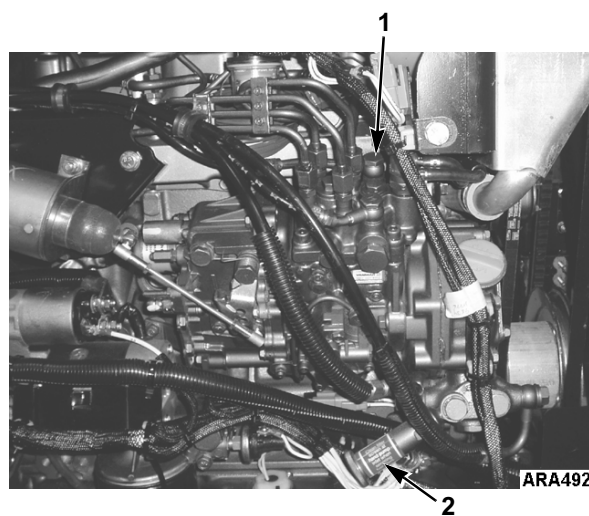

1.	Bleed Screw	2.	Priming Pump
----	-------------	----	--------------

Figure 60: Injection Pump

2. Unscrew the priming pump handle and manually prime the fuel system until air bubbles are no longer visible in the fuel coming out of the bleed screw.
3. Tighten the bleed screw and screw the priming pump handle back in.
4. Loosen the injection lines at the injection nozzles.
5. Crank the engine until fuel appears at the nozzles.
6. Tighten the injection lines.
7. Start the engine and observe the engine run for a few minutes. If the engine fails to start, or starts but stops in a few minutes, repeat the procedure.

Water in the Fuel System

Water in the fuel system can damage the injection pump and nozzles. This damage will subsequently cause more expensive damage to the engine. A large accumulation of water in the bottom of the fuel tank will stop a diesel engine. Water should be drained off during scheduled maintenance inspections. Let the tank set idle for an hour before removing the drain plug from fuel tank. Let water and fuel drain into a container until only fuel is draining from tank. Replace drain plug. DO NOT steam clean fuel tank caps.

NOTE: Some fuel tanks have a check valve in the drain plug fitting. Push the check valve open with a small screw driver to drain water and fuel.

Single Element Fuel Filter/Water Separator Replacement

A single element fuel filter/water separator removes contaminants and water from the fuel. Two orifices in the filter head control the pressure in the fuel system by allowing a certain amount of fuel to return to the tank. One orifice is located in the center of the filter head. It bleeds off water and returns it to the fuel tank. The other orifice is located off-center on the filter head and bleeds off air.

1. Unscrew the filter using a strap wrench. Drain filter. Properly dispose of fuel and filter.

2. Fill the new filter with clean fuel through one of the small openings in the top of the filter body. Do not use the center hole to add fuel to the filter or unfiltered fuel may reach the injection pump. Filling the filter with fuel purges air from the filter.
3. Clean the filter head seal surface. Lubricate filter seal with clean fuel.
4. Hand tighten the filter.

Draining Water from Fuel Tank

Water run through the system may damage the injection pump or nozzles. Damage to the fuel system will subsequently cause more expensive damage to the engine. A large accumulation of water in the bottom of the fuel tank will stop a diesel engine. Water should be drained off during scheduled maintenance inspections to prevent breakdowns. Drain the water off after the fuel tank and unit have remained idle for an hour.

1. Place a container under the fuel tank to catch the draining water and fuel.
2. Remove the drain plug from the bottom of the fuel tank.

NOTE: Some fuel tanks have a check valve in the drain plug fitting. Push the check valve open with a small screw driver to drain the tank.

3. Let the water and fuel drain into the container until no water is visible in the fuel draining from the tank. If the water and fuel do not drain freely, the vent may be plugged. If so, clean or replace the vent.
4. Install the drain plug.

Fuel Strainer

The fuel strainer removes the larger contaminant particles from the fuel before it goes through the fuel transfer pump and the fuel filter/water separator. Inspect the fuel pre-strainer during pretrip inspections and scheduled maintenance inspections. Remove the bowl and clean the screen if it looks dirty or if there is water in the bowl. Fill the bowl with clean fuel when reinstalling the screen and bowl.

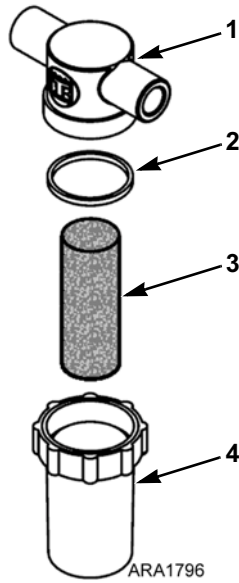

1.	Head
2.	Gasket
3.	Screen
4.	Bowl

Figure 61: Fuel Strainer Components

Engine Speed Adjustment

When the diesel engine fails to maintain the correct engine speed, check the following before adjusting the speed:

1. Bleed the air out of the fuel system. Check the speed.
2. Bleed the air out of the nozzles. Check the speed.

Adjustment Procedure for Standard Units

Make the engine speed adjustments with the engine fully warmed up.

1. Turn the refrigeration unit off so there is no load on the engine.
2. Start the unit and use the Data Menu and the Internal States submenu (or the Commands Menu and the System Setup submenu) to check the engine speed. The engine speed should be 1890 ± 10 RPM with No Load.
3. Loosen the jam nut on the speed adjustment screw.
4. Adjust the screw to change engine RPM.

5. Tighten the jam nut, when the speed is correct.

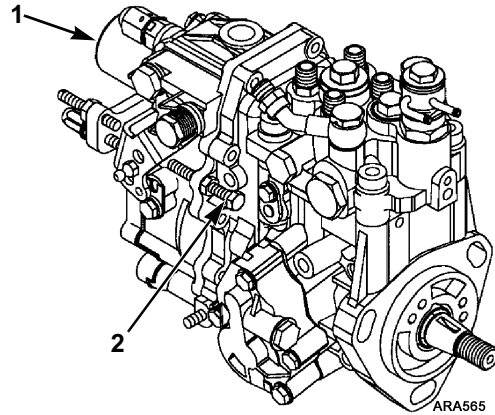

1.	Fuel Solenoid
2.	Speed Adjustment Screw

Figure 62: Engine Speed Adjustment for Standard Unit

Adjustment Procedure for Units with EcoPower Option

Make the engine speed adjustments with the engine fully warmed up.

1. Turn the refrigeration unit off so there is no load on the engine.
2. Start the unit.
3. Enter the Commands Menu and then enter the System Setup submenu. See “System Setup” on page 62.
4. Set the Speed Solenoid to Off in the System Setup submenu.
5. Check the engine speed. The engine speed should be 1560 ± 5 RPM with No Load and the Speed Solenoid Off.
 - a. If necessary, loosen the jam nut on the low speed adjustment screw.
 - b. Adjust the low speed adjustment screw to change engine RPM.
 - c. Tighten the jam nut on the low speed adjustment screw when the speed is correct.
6. Set the Speed Solenoid to On in the System Setup submenu.

7. Check the engine speed. The engine speed should be 1890 ± 10 RPM with No Load and the Speed Solenoid On.
 - a. If necessary, loosen the jam nut on the high speed adjustment screw.
 - b. Adjust high speed adjustment screw to change engine RPM.
 - c. Tighten the jam nut on the high speed adjustment screw when the speed is correct.
8. Exit the System Setup submenu by pressing the **ESCAPE** key as necessary to return to the Main Menu.

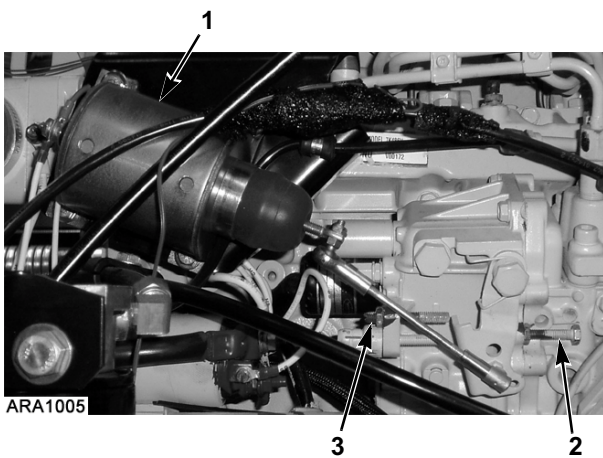

1.	Speed Solenoid
2.	Low Speed Adjustment Screw
3.	High Speed Adjustment Screw

Figure 63: Engine Speed Adjustment for Units with EcoPower Option

Integral Fuel Solenoid

The fuel solenoid contains 2 coils: the pull-in coil, and the hold-in coil. The pull-in coil draws approximately 35 to 45 amperes at 12 volts. The hold-in coil draws approximately 1 ampere at 12 volts. The pull-in coil must be energized to move the injection pump governor linkage to the fuel “ON” position. Once the governor linkage is in the fuel “ON” position, the hold-in coil will keep the linkage in the fuel on position until the 8D circuit is de-energized. The pull-in coil must be de-energized after a few seconds to keep it from being damaged.

Diagnosing the Integral Fuel Solenoid System

NOTE: The fuel solenoid pull-in coil may require 35 to 45 amperes to pull the solenoid plunger in. The unit’s battery must be in good condition. If the battery has enough power to crank the engine over, it has enough power to energize the fuel solenoid pull-in coil.

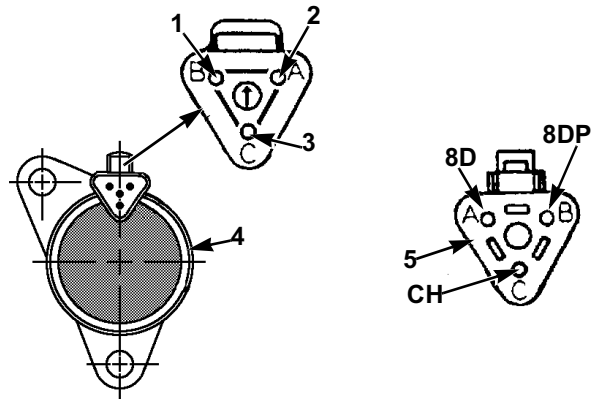

1.	Pin B: White (8DP) Wire
2.	Pin A: Red (8D) Wire
3.	Pin C: Black (CH) Wire
4.	Fuel Solenoid and Connector
5.	Main Wire Harness Connector and Pins: Pin A = 8D Pin B = 8DP Pin C = CH

Figure 64: Integral Fuel Solenoid Harness Connections

If you suspect that the engine does not operate because the fuel solenoid is not operating correctly, use the following procedure:

1. Check the operation of the fuel hold relay and the fuel pull relay.
 - a. Go to the Commands Menu and use the PTI submenu or the Manual Function Test submenu to test the relays. See “Commands Menu” on page 58, “PTI” on page 59, and “Manual Function Test” on page 60.
 - b. If a relay fail the test, replace the relay.
 - c. If the relays pass the tests, go to step 2.
2. Disconnect wire 8S from the starter solenoid.
3. Disconnect the fuel solenoid wire connector from the main wire harness.
4. Place the Unit On/Off switch in the “ON” position.
5. Check the voltage on 8D circuit in the main wire harness connector for the fuel solenoid. Refer to Figure 64 or the unit wiring diagram to identify the pins in the wire harness and fuel solenoid connectors.
 - a. If battery voltage is not present on the 8D circuit, check the 8D circuit and related components for a fault.
 - b. If battery voltage is present on the 8D circuit, go to step 6.
6. Check CH circuit in the main wire harness at the fuel solenoid connector for continuity to a good chassis ground.
 - a. If there is no continuity between CH circuit and a good chassis ground, check the CH wire for an open circuit.
 - b. If there is continuity between CH circuit and a good chassis ground, go to step 7.
7. Turn the unit off.
8. Place a jumper wire between the CH circuit in the connector on the fuel solenoid and a good chassis ground.
9. Test the pull-in coil by momentarily placing a jumper between the 8DP circuit pin in the connector on the fuel solenoid and the positive battery terminal. The fuel solenoid should make a definite click when the pull-in coil is energized. It should click again when the pull-in coil is de-energized.

NOTE: The pull-in coil may draw 35 to 45 amperes so do not leave the jumper connected to pin 8DP for more than a few seconds.

 - a. If the pull-in coil does not energize, check the resistance of the pull-in coil by placing an ohmmeter between 8DP circuit and the CH circuit in the connector on the fuel solenoid. The resistance of the pull-in coil should be 0.2 to 0.3 ohms. Replace the fuel solenoid if the resistance of the pull-in coil is not in this range.
 - b. If the pull-in coil does energize, go to step 10.
10. Test the hold-in coil.
 - a. Energize the hold-in coil by placing a jumper between the 8D circuit in the connector to the fuel solenoid and the positive battery terminal.
 - b. Momentarily energize the pull-in coil by placing a jumper between the 8DP circuit in the connector to the fuel solenoid and the positive battery terminal. The fuel solenoid should make a definite click when the pull-in coil is energized, but should not click when the pull-in coil is de-energized.
 - c. De-energize the hold-in coil by removing the jumper from the 8D circuit and the positive battery terminal. The fuel solenoid should make a definite click when the hold-in coil is de-energized.
 - d. If the hold-in coil does not function properly, check the resistance of the hold-in coil by placing an ohm-meter between the 8D circuit and the CH circuit in the connector to the fuel solenoid. The resistance of the hold-in coil should be 24 to 29 ohms. If the resistance of the hold-in coil is not in this range, replace the fuel solenoid.

11. Reconnect the main wire harness connector to the fuel solenoid connector.
12. Connect wire 8S to the starter solenoid.

Fuel Solenoid Replacement

1. Disconnect wire 8S from the starter solenoid.
2. Disconnect the fuel solenoid wire connector.
3. Remove the old fuel solenoid.
4. Connect the main harness connector to the new fuel solenoid.
5. Place the Unit On/Off switch in the “ON” position to energize the fuel solenoid.

NOTE: The fuel solenoid must be energized when it is being installed. If it is not, the plunger and the linkage may not line up correctly.

6. Place the O-ring in the groove in the end of the fuel injection pump. Make sure that the O-ring is positioned correctly during installation to avoid damage and leaks.
7. Install the new fuel solenoid.
8. Turn the unit Off.
9. Connect wire 8S to the starter solenoid.

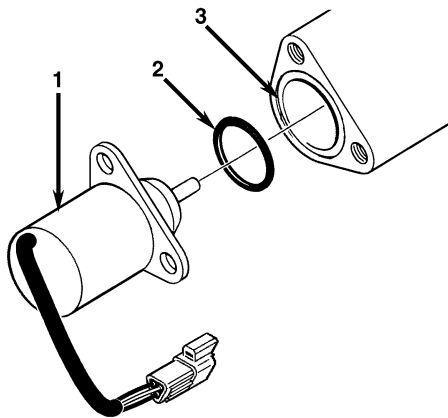

AXA0298

1.	Integral Fuel Solenoid
2.	O-ring
3.	Fuel Injection Pump Groove

Figure 65: Integral Fuel Solenoid Components

Injection Pump Service and Timing

Injection Pump Removal

The injection pump drive gear will not fit through the gear housing when removing the pump. The gear must be separated from the pump using tool P/N 204-1011. When this tool is used, it is not necessary to remove the water pump belt, fuel pump, crankshaft pulley, crankshaft seal or front plate. See Figure 68 “Injection Pump Gear Tool” on page 104.

1. Note the alignment of the index marks on the injection pump and the gear case. The index mark on the injection pump is usually aligned with the single index mark on the gear case. If not, mark it so the injection pump can be returned to the same position when it is reinstalled.

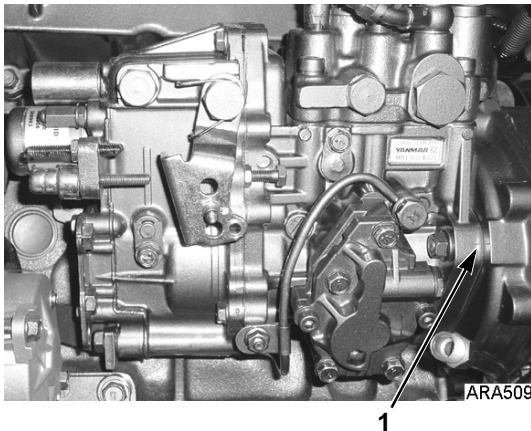

1.	Index Marks
----	-------------

Figure 66: Index Mark Location

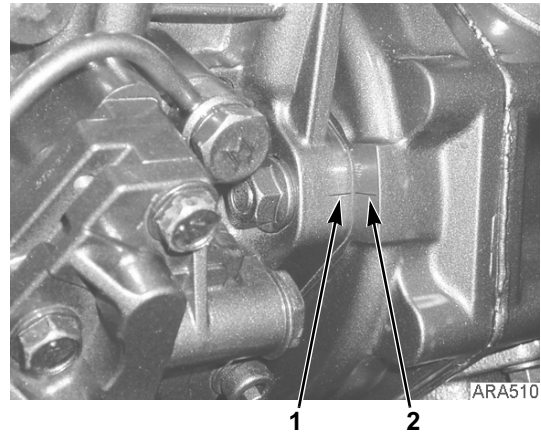

1.	Index Mark on Injection Pump
2.	Index Mark on Gear Case

Figure 67: Index Mark Alignment

2. Remove the starter for clearance. Also remove the fuel lines, harness and mounting hardware from the injection pump. Cover all injection lines and fuel lines with plastic covers or tape. The smallest amount of dirt can damage the fuel system.
3. Remove the cover plate from the gear case. Remove the nut and lockwasher that secure the gear to the injection pump shaft. Use a shop rag to prevent the lock washer or nut from falling into the gear case.

NOTE: *The injection pump gear assembly is made of three pieces; the flange, the gear, and the transfer pump cam. Do not loosen or remove the four bolts that fasten the gear to the flange because that changes the timing.*

4. Use the hardware from the cover plate to attach the tool plate (P/N 204-1011) to the gear case. Attach the plate with the marked side pointing up and out away from the case.
5. Align the threaded holes in the injection pump gear with the two holes in the tool plate by rotating the engine crankshaft. Attach the gear to the tool plate with the screws provided with the tool plate.
6. Thread the long screw into the small end of the adapter (both parts are supplied with the tool plate). Insert the adapter into the tool plate. Carefully align the screw over the center

of the injection pump shaft. Then rotate the screw to force the injection pump shaft from the gear.

- Remove the screw and adapter, leaving the tool plate in position. This holds the gear in the proper tooth alignment until the injection pump is re-installed.

Injection Pump Installation

- Rotate the injection pump shaft to align the key with the keyway in the gear. Take care to make sure the key mates with the keyway. Then insert the injection pump shaft into the gear.
- Fasten the injection pump to the gear case using the correct hardware. Make sure to align the index marks on the injection pump and the gear case like they were in step 1 of “Injection Pump Removal”.

NOTE: If a different injection pump is being installed, see “Injection Pump Timing” on page 105 to set the timing.

- Remove the screws that hold the gear to the tool plate and remove the tool plate.
- Fasten gear to injection pump shaft with a lock washer and nut. Use a shop rag to prevent the lock washer or nut from falling into the gear case. Torque the nut to 58 to 65 ft-lb (78 to 88 N•m).
- Fasten the cover plate to the gear case. Install the fuel lines, harness and mounting hardware from the injection pump. Also install the starter.

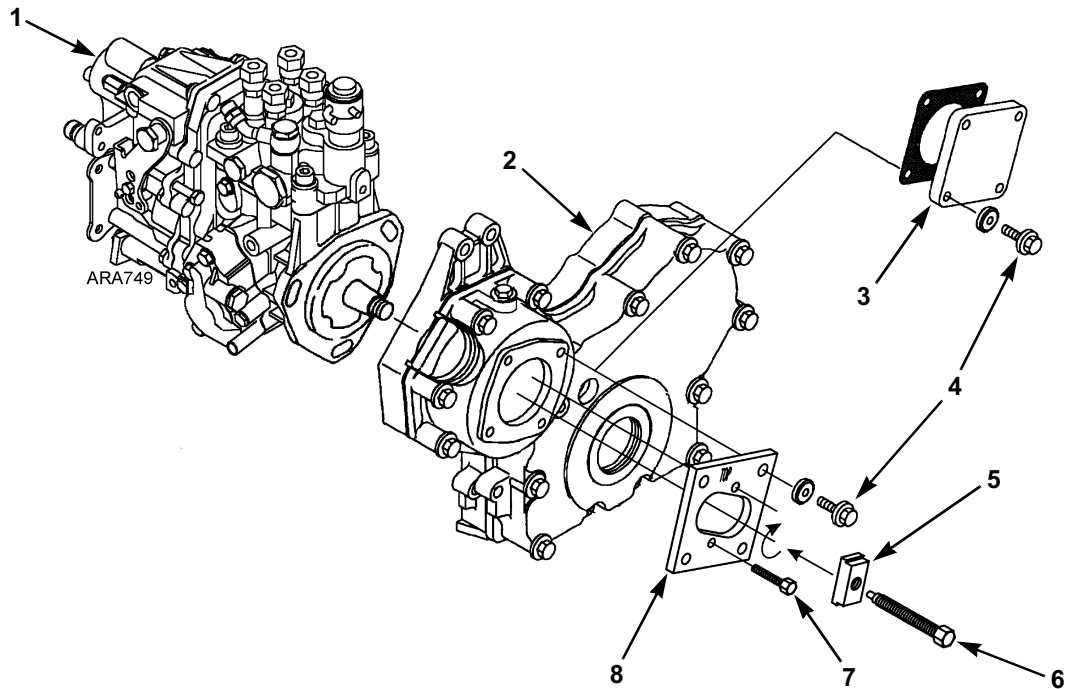

1.	Injection Pump	5.	Adapter (Tool)
2.	Gear Case	6.	Tool Long Screw (Tool)
3.	Cover Plate	7.	Tool Short Screw (Tool)
4.	Cover Plate Bolt	8.	Tool Plate (Tool)

Figure 68: Injection Pump Gear Tool

Injection Pump Timing

Use this timing procedure when installing a new injection pump. It is not necessary to use this timing procedure when removing and reinstalling the original injection pump. In that case, align the index marks on the injection pump and the gear case as they were before removing the injection pump.

1. Before removing the old injection pump, note the alignment of the index marks on the injection pump and the gear case. The index mark on the injection pump is usually aligned with the index mark on the gear case. If not, make a mark on gear case in line with the index mark on the injection pump (see Figure 71).

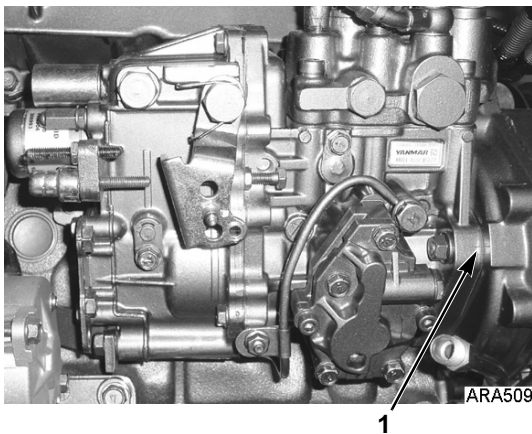

1.	Index Marks
----	-------------

Figure 69: Index Mark Location

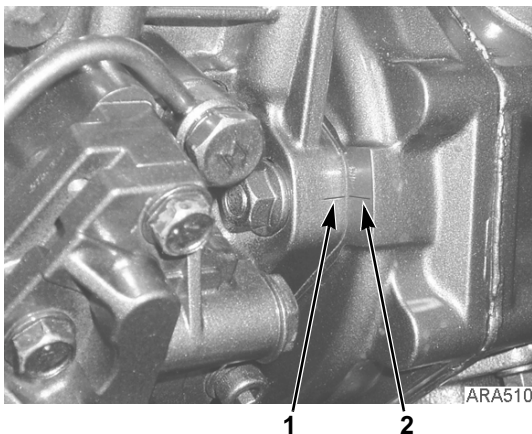

1.	Index Mark on Injection Pump
2.	Index Mark on Gear Case

Figure 70: Index Mark Alignment

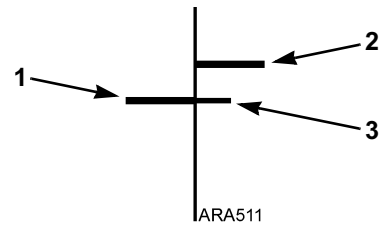

1.	Index Mark on Injection Pump
2.	Existing Index Mark on Gear Case
3.	Make New Mark on Gear Case If Needed

Figure 71: Marking Gear Case

2. Clean the area with brake cleaner or something similar. Place an injection angle sticker on the gear case so the center line on the sticker is aligned with the index mark on the injection pump. An injection angle sticker is provided with the new injection pump.

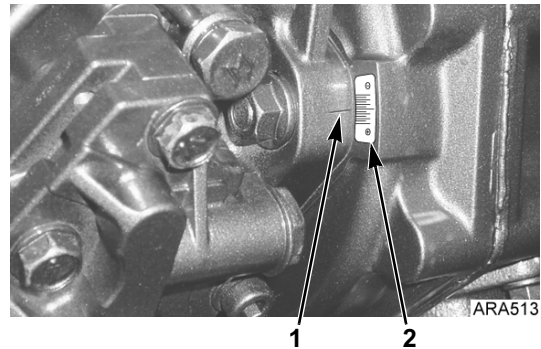

1.	Index Mark on Injection Pump
2.	Injection Angle Sticker

Figure 72: Place Injection Angle Sticker on Gear Case

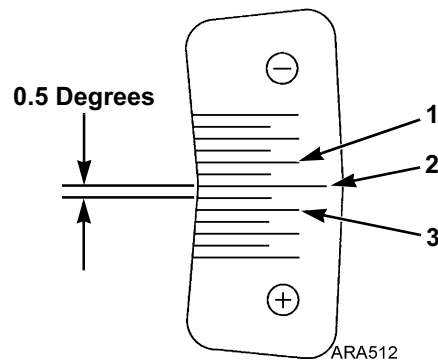

1.	-1.0 Degrees Mark
2.	Center Line (0 Degrees Mark)
3.	+1.0 Degrees Mark

Figure 73: Injection Angle Sticker

- Remove the old injection pump. Use the injection pump gear tool P/N 204-1011 to remove the injection pump gear without removing the timing gear cover (see “Injection Pump Removal” on page 103).

NOTE: Remove the injection pump gear by removing the nut and lock washer that secure the injection pump gear assembly to the injection pump shaft. The injection pump gear assembly is made of three pieces; the flange, the gear, and the transfer pump cam. Do not loosen or remove the four bolts that fasten the gear to the flange because that changes the factory-set timing. The EPA certification is based on the factory-set timing. If the factory-set timing is changed, the EPA certification is void.

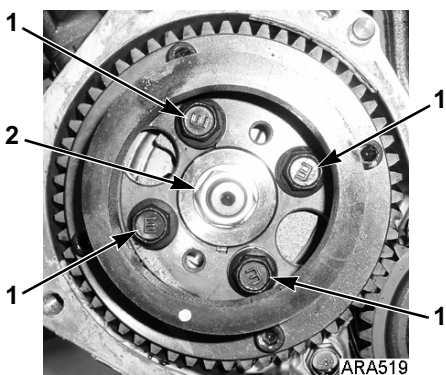

1.	Do Not Loosen or Remove These Four Bolts
2.	Remove Nut and Lock Washer

Figure 74: Removing Injection Pump Gear

- Record the injection angle marked on the old injection pump (see the following photographs). The injection angle mark is located on the side of the pump facing the engine. The injection angle mark on the pump does not use a decimal point. Add a decimal point before the last digit of the injection angle mark to get the injection angle. The injection angle mark in the following photographs is 67. That equals an injection angle of 6.7 degrees.

Examples	
Injection Angle Mark	Injection Angle
67	6.7 Degrees
85	8.5 Degrees

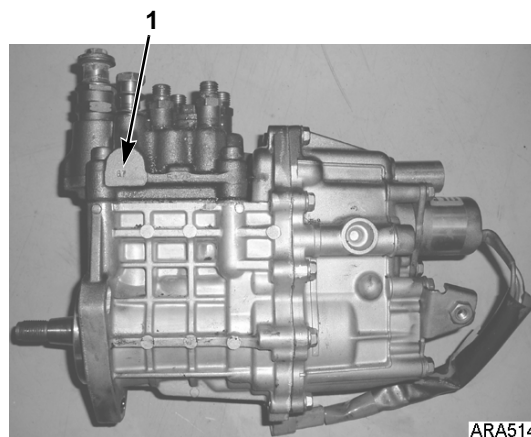

1. Injection Angle Mark

Figure 75: Injection Angle Mark Location

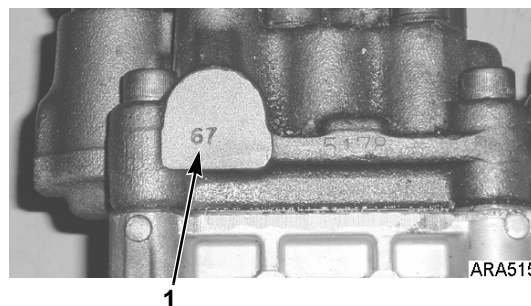

1. Injection Angle Mark

Figure 76: Injection Angle Mark

NOTE: If you cannot read the injection angle mark, contact the Thermo King Service Department with the injection pump serial number or the engine serial number and they will provide the injection angle. The injection pump serial number is located on the bottom of the sticker on the injection pump.



1. Injection Pump Serial Number

Figure 77: Injection Pump Serial Number Location

- Record the injection angle marked on the side of the new injection pump.
- Calculate the injection angle difference by subtracting the injection angle of the old injection pump from the injection angle of the new injection pump.

Examples		
Injection Angle of New Injection Pump (Degrees)	8.5	6.1
– Injection Angle of Old Injection Pump (Degrees)	– 6.7	– 6.7
= Injection Angle Difference (Degrees)	= +1.8	= –0.6

- Install the new injection pump on the gear case and position it so the index mark on the injection pump is aligned with the mark equal to the injection angle difference on the injection angle sticker (see the following examples). Tighten the injection pump mounting nuts when the index mark is aligned as necessary with the injection angle sticker.

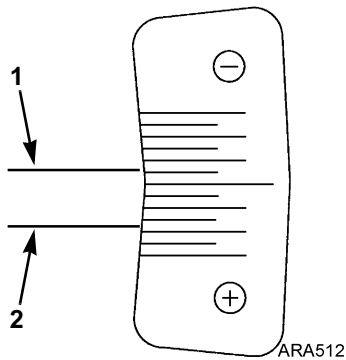

1.	Injection Pump Index Mark at –0.6 Degrees
2.	Injection Pump Index Mark at +1.8 Degrees

Figure 78: Examples of Injection Pump Index Mark Alignment with Injection Angle Sticker

- Install the injection pump gear, lock washer, and nut. Torque the nut to 58 to 65 ft-lb (78 to 88 N•m).

NOTE: If the timing gear cover was removed to remove the injection pump gear, make sure the timing marks on the timing gears are aligned as shown below. It helps to install the idler gear last when aligning the timing marks.

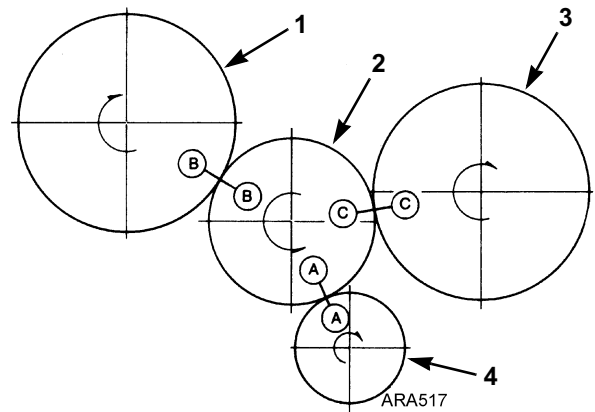

1.	Fuel Injection Pump Gear
2.	Idler Gear
3.	Camshaft Gear
4.	Crankshaft Gear

Figure 79: Timing Mark Alignment

NOTE: The oil pump is located in the timing gear cover on TK486V engines. The inner rotor of the oil pump fits around the crankshaft gear. Make sure that the flat sides of the inner rotor are aligned with the flat sides on the crankshaft gear when installing the timing gear cover.

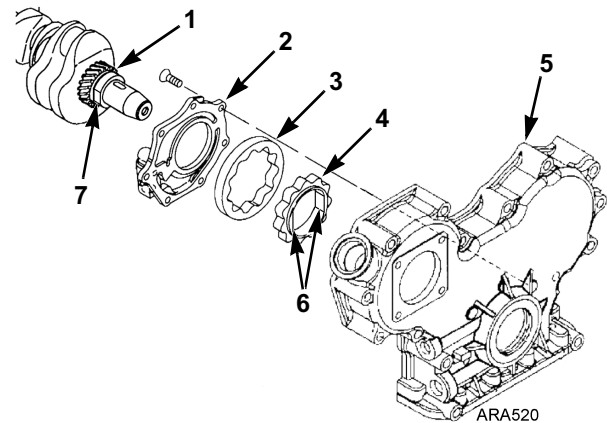

1.	Crankshaft Gear
2.	Oil Pump Cover
3.	Outer Rotor
4.	Inner Rotor
5.	Timing Gear Cover
6.	Flat Sides on Inner Rotor
7.	Flat Side on Crankshaft Gear

Figure 80: Align Flat Sides of Crankshaft Gear with Flat Sides of Inner Rotor in Timing Gear Cover

Trochoid Feed Pump

The TK486V engine has a trochoid feed pump on the fuel injection pump. The trochoid feed pump supplies fuel to the injection pump at a pressure of 450 to 600 kPa (65 to 87 psi) in high speed. Check the outlet pressure of the trochoid feed pump by removing the plug and attaching a pressure gauge to the port shown below. The plug has M12x1.25 threads. You will have to make an adaptor to attach a pressure gauge. Replace the trochoid feed pump if the outlet pressure is below the pressure specifications in the following table.

Trochoid Feed Pump Outlet Pressure	
Cranking	103-206 kPa (15-30 psi)
Low Speed	206-345 kPa (30-50 psi)
High Speed	450-600 kPa (65-87 psi)

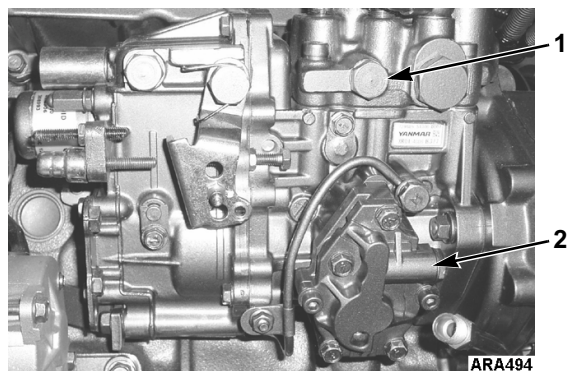

1.	Trochoid Feed Pump Outlet Pressure Port
2.	Trochoid Feed Pump

Figure 81: Trochoid Feed Pump Location

Trochoid Feed Pump Leaks

Internal – If the seal in the trochoid feed pump fails, it could allow some fuel to leak into the engine oil. A faulty injection nozzle or fuel transfer pump can also dilute the engine oil with fuel. Replace the trochoid feed pump if the engine oil is being diluted with fuel and a faulty injection nozzle or fuel transfer pump is not the cause.

External – Replace the O-ring seal between the trochoid feed pump and the injection pump if oil is leaking. Torque the bolts to prevent leaks (8 to 10 N•m [6 to 7 ft-lb]).

Replace all O-rings if fuel is leaking. Torque the Allen head screws and Hex head bolts to prevent leaks (8 to 10 N•m [6 to 7 ft-lb]).

Trochoid Feed Pump Replacement

Use the following procedure to replace the trochoid feed pump.

1. Remove the four hex head screws that attach the trochoid feed pump to the injection pump. Do not remove the two Allen head screws.

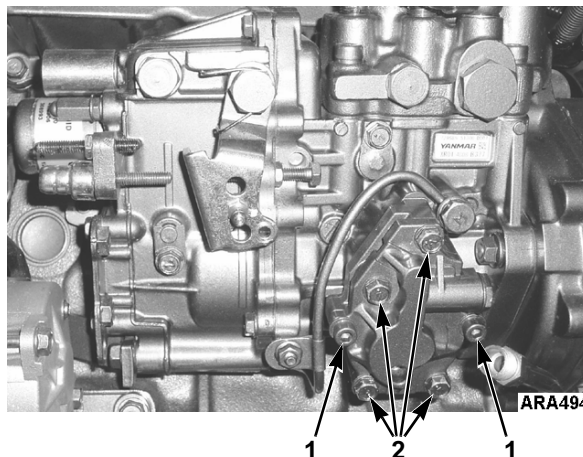

1.	Allen Head Screws (Do Not Remove)
2.	Hex Head Screws

Figure 82: Trochoid Feed Pump Removal

2. Remove the trochoid feed pump from the injection pump.

NOTE: *The gear on the trochoid feed pump is lubricated with engine oil. Some engine oil might leak out of the injection pump when the trochoid feed pump is removed. The trochoid feed pump does not need to be timed when it is installed. Clean the area on the injection pump from which the trochoid feed pump was removed.*

- Place new O-rings on the new trochoid feed pump and make sure it is clean.

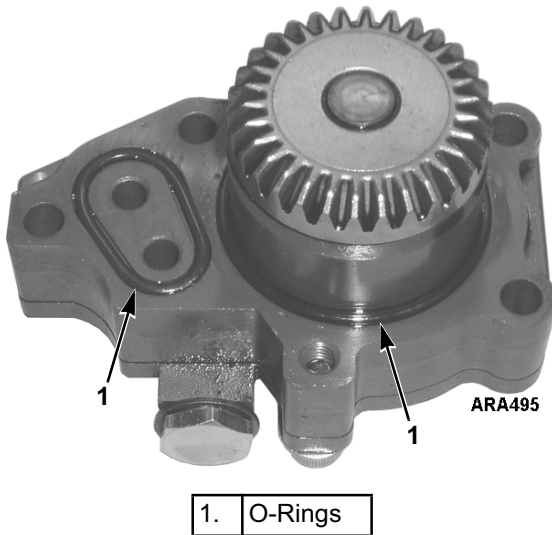

Figure 83: Trochoid Feed Pump

- Place the new trochoid feed pump on the injection pump.
- Install and tighten four hex head screws that attach the trochoid feed pump to the injection pump. Torque the hex head screws to 8 to 10 N•m (6 to 7 ft-lb).

Cold Start Device

The TK486V engine has a cold start device located on the fuel injection pump. The cold start device has a plunger that retracts at engine coolant temperatures below 5 C (41 F) to advance the injection timing approximately 2 degrees. The plunger controls the position of a piston in the injection pump to change the timing. The plunger is extended and the injection timing is normal at engine coolant temperatures above 5 C (41 F). Check the operation of the cold start device if it is difficult to start the engine in cold weather.

NOTE: Do not pull the plunger out of a cold start device because that will damage it.

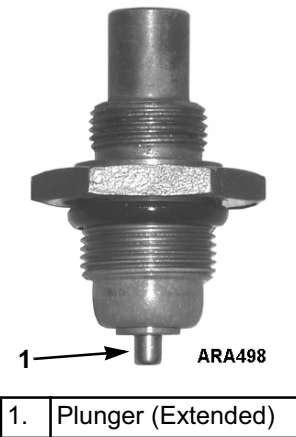

Figure 84: Cold Start Device

Checking Cold Start Device Operation

Use the following procedure to check the operation of the cold start device. The engine coolant temperature must be below 0 C (32 F) to start the procedure.

- Place the On/Off switch in the On position.
- Enter the Analog Inputs submenu in the Data Menu before the engine starts and check the coolant temperature to make sure it is below 0 C (32 F).
- Let the engine start, then enter the Internal States submenu in the Data Menu to check the engine rpm. The engine rpm should be approximately 100 rpm higher than normal (see Specifications).
- Let the engine run to warm up and use Analog Inputs and Internal States submenus to check the coolant temperature and engine rpm. When the coolant temperature rises above 5 C (41 F), the engine rpm should drop back to normal. Replace the cold start device if the engine rpm does not drop approximately 100 rpm when the engine warms up.

Cold Start Device Replacement

1. Drain the engine coolant.
2. Remove the banjo bolt that fastens the engine coolant fitting to the cold start device. Use a backup wrench on the cold start device if necessary.

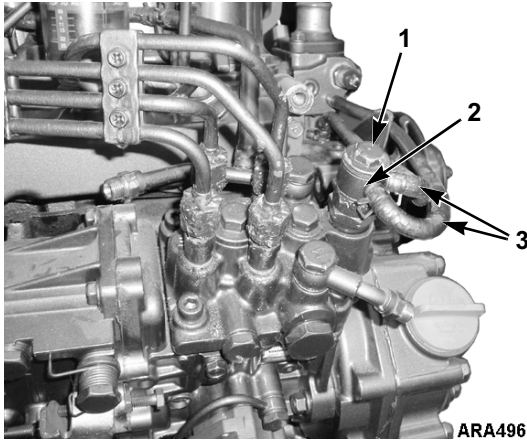

1.	Banjo Bolt
2.	Engine Coolant Fitting
3.	Coolant Hoses to Cold Start Device

Figure 85: Remove Engine Coolant Fitting

3. Remove the cold start device from the injection pump fitting. Use a backup wrench on the injection pump fitting if necessary.

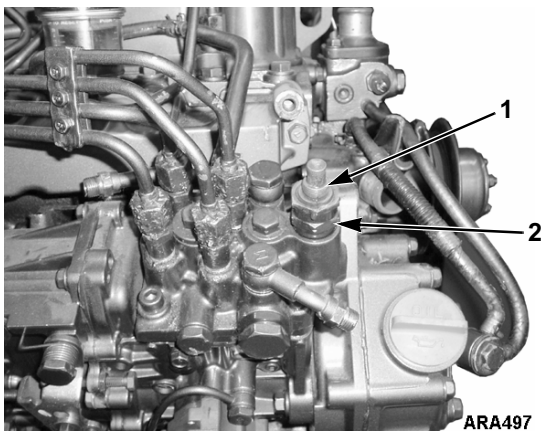

1.	Cold Start Device
2.	Injection Pump Fitting

Figure 86: Remove Cold Start Device

4. Make sure the piston inside the injection pump fitting is clean.

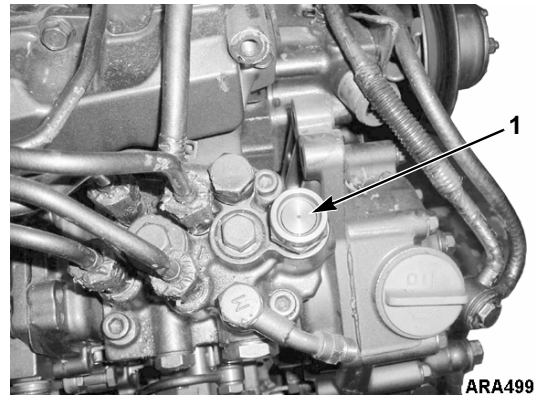

1.	Piston
----	--------

Figure 87: Clean Piston

5. Install the new cold start device with a new O-ring in the injection pump fitting. Torque the cold start device to 30 to 35 N•m (22 to 26 ft-lb).
6. Install the coolant fitting and banjo bolt on the cold start device. Torque the banjo bolt to 22 to 25 N•m (16 to 18 ft-lb).
7. Refill the engine cooling system and make sure to bleed the air from the cooling system.

Adjusting Engine Valve Clearance

Valve clearance should be checked as required. It is very important that valves be adjusted to the correct specifications for satisfactory engine operation. Insufficient valve clearance will result in compression loss and misfiring of cylinders. This will result in burned valves and seats. Excessive valve clearance will result in noisy valve operation and abnormal wear of the valves and rocker arms. The intake and exhaust valves are adjusted with the valve in the closed position.

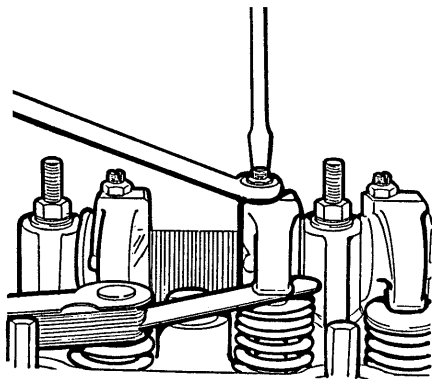

AXA0304

Figure 88: Adjusting the Valve Clearance

Complete the following steps to adjust the engine valve clearance.

1. Remove the rocker arm cover.
2. Remove the round cover (plug) from the timing mark access hole on the front of the bell housing.



WARNING: Loosen all of the injection lines at the injection nozzles to prevent the possibility of the engine firing while it is being rotated.

3. Place the engine at top dead center of the compression stroke for the number one cylinder.
 - a. Rotate the engine in the normal direction of rotation (clockwise viewed from the water pump end). Rotate the engine until the 1-4 timing mark on the flywheel lines up with the index mark in access hole.

- b. Check the rocker arms on the number one cylinder.
- c. If the rocker arms are loose, the engine is at top dead center of the compression stroke for the number one cylinder.
- d. If the rocker arms are tight, the engine is at top dead center of the exhaust stroke for the number one cylinder. Rotate the engine 360 degrees to place the engine at top dead center of the compression stroke for the number one cylinder.

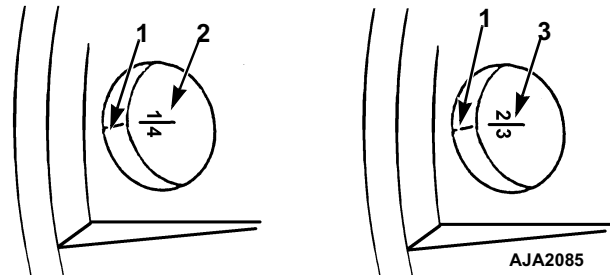

1.	Timing Mark
2.	Top Dead Center Mark for Cylinders 1 and 4
3.	Top Dead Center Mark for Cylinders 2 and 3

Figure 89: Timing Marks

4. Check the valve clearance of both valves for the number one cylinder with a feeler gauge. Also check the valve clearance for the intake valve for the number two cylinder, and the exhaust valve for the number three cylinder. The clearance for both the intake and exhaust valves should be 0.15 to 0.25 mm (0.006 to 0.010 in.).

NOTE: Check to make sure that the valve stem cap is in good condition and is positioned squarely on the top of the valve stem. Replace the valve stem cap if it shows significant wear.

5. Loosen the locknut and adjust the valves as required by turning the adjustment screw.
6. Hold the adjustment screw while tightening the locknut.
7. Recheck the valve clearance.

8. Rotate the engine one full turn (360 degrees) to place the engine at top dead center of the compression stroke for the number four cylinder. Rotate the engine clockwise as viewed from the water pump end. Align the 1-4 timing mark on the flywheel with the index mark in the access hole. This places the engine at top dead center of the compression stroke for the number four cylinder.
9. Check and adjust both valves for the number four cylinder. Also check the valve clearance for the intake valve for the number three cylinder, and the exhaust valve for the number two cylinder. The clearance for both the intake and exhaust valves should be 0.15 to 0.25 mm (0.006 to 0.010 in.).
10. Replace the rocker arm cover and the timing mark access hole cover. Tighten the fuel injection lines when finished.

Engine	Rear Flywheel End				Front Pulley End			
	1		2		3		4	
Valve Arrangement	E	I	E	I	E	I	E	I
Piston in No. 1 cylinder is at TDC on compression stroke	○	○		○	○			
Piston in No. 4 cylinder is at TDC on compression stroke			⊖			⊖	⊖	⊖

Figure 90: Valve Adjustment and Cylinder Configurations

Belt Tension Adjustment and Belt Replacement

NOTE: Belt tension specifications are measured using Thermo King belt gauge tool, P/N 204-427.

Belts should be regularly inspected during unit pretrip for wear, scuffing or cracking and correct tension.

Correct belt tension is critical for correct unit operation. Belts that are too loose will slip, squeal or whip causing excessive vibration levels and poor unit performance. Belts that are too tight will put too much strain on the belt fibers and bearings, causing premature belt and bearing failures. New belts should be tensioned cold.

NOTE: DO NOT attempt to remove or install belts without loosening adjustments. Belts that are installed by prying will fail prematurely due to internal cord damage.

⚠ WARNING: DO NOT jump belts on by cranking the engine. Personal injury may result.

⚠ WARNING: DO NOT attempt to adjust belts with the unit operating.

⚠ WARNING: With the unit On/Off switch in the “ON” position, the unit may start operation at any time without prior warning. Switch unit On/Off switch to “OFF” position before performing maintenance or repair procedures.

The water pump belt tension should read 15 to 35 on the belt tension gauge.

1. Remove the nuts from the water pump pulley.
2. Remove the pulley sliding section and add or remove shims to adjust the belt tension.

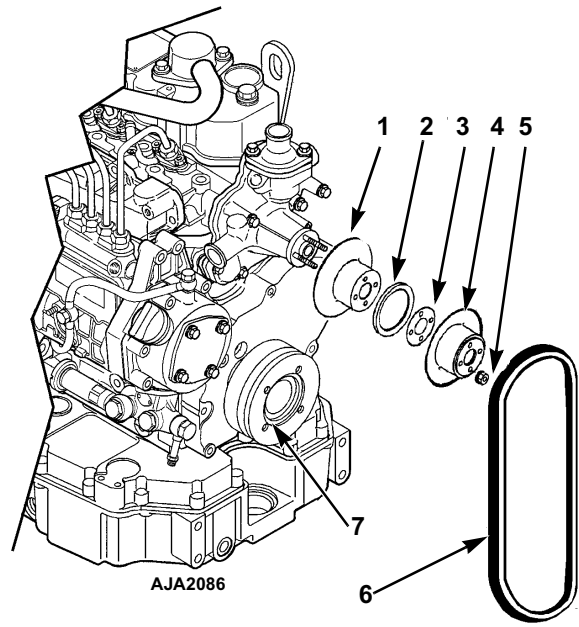

Water Pump Pulley (Items 1 - 5)	
1.	Fixed Pulley Section
2.	Spacer
3.	Shims (4)
4.	Sliding Pulley Section
5.	Nut (4)
6.	Belt
7.	Crankshaft Pulley

Figure 91: Water Pump Fan Belt

3. Reinstall the belt on the pulley and replace the sliding pulley section on the pulley.
4. Tighten the mounting nuts on the water pump pulley.
5. The belt tension should read 15-35 on the belt tension gauge.

NOTE: When adjusting the belt tension using shims and adjustable pulleys, the belt may still feel loose when the belt tension gauge indicates the correct tension. Allow 18 to 25 mm (0.75 to 1.0 inch) deflection with 3 to 4 kg (6 to 9 lb) of force.

Alternator Operation and Diagnosis

General Description

The 460/230 Vac alternator system consists of two principal components: the main alternator, and the SG+ Controller.

The main alternator may be subdivided into the 4-pole main rotating field and the main stator winding.

The main rotating field, the rotating rectifier and the exciter armature are all mounted on a common shaft. Output of the exciter is rectified by the shaft mounted rotating bridge rectifier. This provides excitation to the main alternator rotating field.

The SG+ Controller energizes (and controls) the exciter field. The output from the main winding builds up until the voltage and amperage reaches the rated amount. The controller then decreases field current, and the alternator maintains the proper output voltage.

Dual Voltage Alternator

The generator set is factory wired for 460V power output. The alternator output can be changed to 230V by changing the jumper wire connections at the terminal strips in the control box. See “Rewiring Procedures for Changing the Generator Set Output Voltage” on page 123.

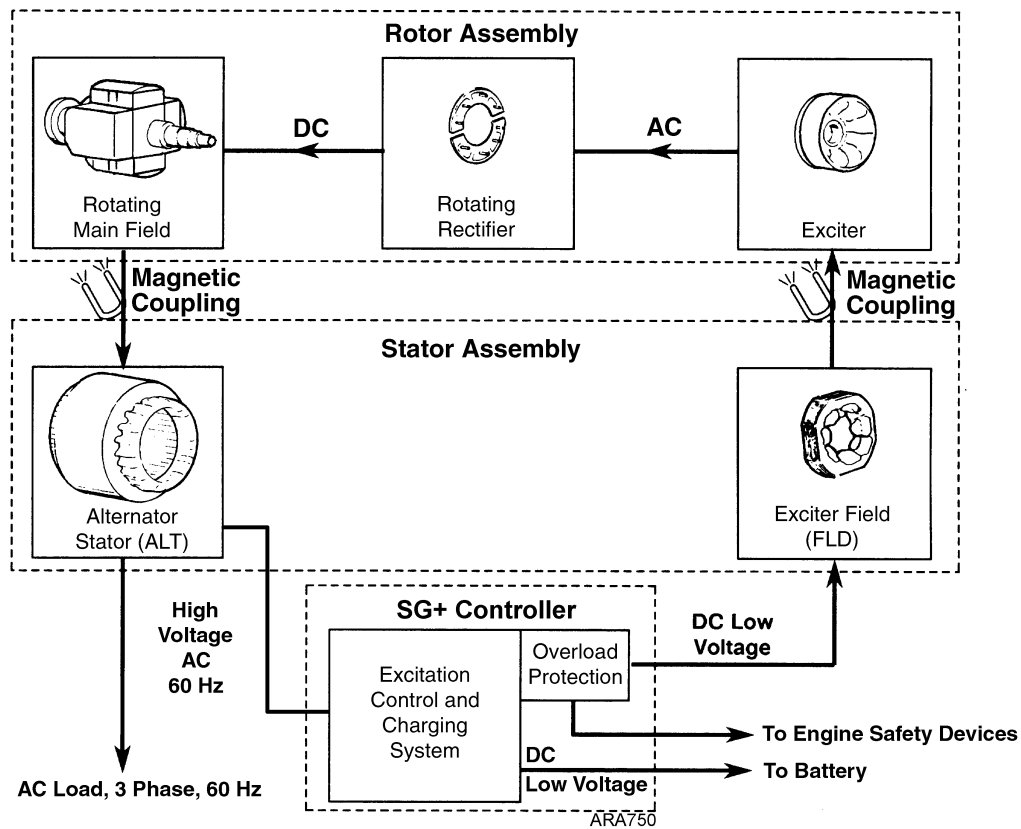

Figure 92: 460/230 Vac Alternator Component Function

Alternator Function

Starting Excitation

The initial excitation for the alternator is supplied by the SG+ Controller approximately 15 seconds after the engine starts. The controller energizes wire F1, which sends the current through the exciter field to build voltage in the stator windings. The current then travels through wire F2 where the circuit is completed to chassis ground.

NOTE: When the Delayed Cold Start feature is set to ON, the exciter field is not energized until the engine temperature rises to 32 C (90 F).

Running Excitation and Control

The magnetic field that was formed in the exciter field stator winding by current from the controller induces a current in the exciter rotating winding. This current is changed from three-phase ac to dc by the rotating rectifier. The dc current is transferred to the main alternator field winding. The main alternator field now becomes magnetic.

The magnetic field formed in the main field winding now induces a voltage in the alternator stator windings. This voltage is either 230 Vac or 460 Vac, 3-phase, depending on stator connections.

It is sent out of the alternator stator leads to the power plug and then to the load. The controller is tapped into the alternator stator leads. The controller reads the alternator output voltage and steps this voltage down to around 12 Vac (1/20th of output voltage). This current is rectified to dc current and is used to charge the battery and energize the exciter field. The controller monitors the alternator output voltage and adjusts the output to the exciter field as necessary to maintain the alternator output at the correct voltage.

Battery Charging

The unit battery is recharged by the alternator through the controller, which performs the functions of a voltage regulator and rectifier. Fuse S12 (30 amps) protects the battery charger output circuit.

Overload Shutdown

The overload shutdown is provided by the controller.

If an overload condition becomes more than temporary, the reduction in alternator output voltage due to the overload causes the controller to increase field current through wire F2. The controller senses the overload current and then de-energizes the fuel solenoid to stop the engine.

If the controller shuts down unit operation, it indicates one of the following:

1. There is a malfunction in the load causing the load to fail to start or to draw single phase current.
2. The engine speed or power is low due to improper speed adjustment, fuel supply problems or other mechanical conditions while the generator is supplying motor starting current to the load.
3. Internal component failure in the excitation control system, resulting in excessive field current. This includes possible malfunction of protective elements in the excitation control.
4. Failure in the alternator rotating elements (exciter armature, rotating diode assemblies or main field) can cause the regulator to supply excessive exciter field current.
5. Engine shutdown on low engine oil level, low oil pressure or high water temperature.

Alternator Diagnosis

Preliminary Checks

Before attempting the more complicated diagnosis procedures, check the following items to ensure a superficial problem is not overlooked.

NOTE: Further diagnosis is a waste of time until these items are checked, since a problem in one of these areas will influence test results.

1. If the generator malfunction is accompanied by excessive black exhaust smoke and engine lugging, double check all possible engine problems such as fuel supply, injection timing, engine speed, restricted air cleaner, etc.
2. Disconnect the refrigeration unit from the generator and check the output voltage at the plug. Voltage between the three phases should be between 230 to 250 Vac or 400 to 500 Vac depending on engine speed and whether the alternator stator is wired for 230 or 460 Volt operation. All three phases should be within 3% of each other. If the voltages appear normal, make sure the refrigeration unit is not at fault. Reconnect refrigeration unit and run in Cool mode. Check the amperage draw with an induction type ammeter (amprobe), and compare it with the load plate on the refrigeration unit.
3. Check all push-in plugs on control circuits for loose pins or sockets. Make sure all wire terminals are tight.

Test Instruments

If the preceding checks did not uncover the cause of the malfunction, more extensive diagnosis procedures will be required. The following tests will require various electrical test instruments, and the technician performing the tests should have a good working knowledge of their basic electrical principles.

The tests are intended to determine whether the source of difficulty lies in the generator itself or in the excitation control system. Following the procedures carefully will, in many cases, avoid unnecessary dismantling and reassembly of the generator when easily corrected problems may exist in the external circuitry.

The test instruments required:

1. AC-DC voltmeter 2.5 Volts to 500 V ranges ($\pm 2\%$ max. error).
2. AC induction ammeter (amprobe).
3. DC ammeter (preferably induction type TK No. 204-947).
4. Ohmmeter.
5. Megohmmeter (Megger®)

Alternator Troubleshooting

Listed below are the categories in which most generator malfunctions will fall. Following each category are a number of possible component failures that may cause the malfunction. Listed with each component is the test used to check the component.

NOTE: Always use Test 1 first to determine if the alternator or the controller is at fault.

1. Generator set has low or no output voltage (system overload).
 - a. Controller is not exciting alternator (Test 1).
 - b. Exciter field circuit in alternator is open circuit (Test 4).
 - c. Alternator stator, main rotating field, rotating rectifier or rotating exciter armature is defective (Test 5).
2. Generator set tries to pick up the load but engine labors excessively, eventually causing a system overload condition.
 - a. Mechanical problems with engine (see preliminary check 1).
 - b. Excessive load from refrigeration unit malfunction (see preliminary check 2).
 - c. Defect in controller, rotating field, rotating bridge, alternator main field or alternator stator (Test 1 and Test 5).
3. Unit battery undercharged.
 - a. Battery defective.
 - b. Fuse SI2 bad.
 - c. Controller fault (Test 2).

Test 1 - Determine if Problem is in Controller or Alternator

1. Need to put the genset in a non-excitation condition. Unplug the water temperature sensor and connect a spare sensor with a temperature of 29 C (85 F) or below. If no spare sensor is available connect a 1500 - 1550 ohm resistor across the WTS and WTN wires.

NOTE: NOTE: Units with Eco Power will run in Low speed 400 V 50 Hz operation.

2. Disconnect the J6 (green) connector from controller
3. Start the genset and let run for 1-2 minutes. Check for residual AC voltage at T1-T2, T1-T3, and T2-T3. Reading should be 50 to 120 VAC.
 - a. If residual voltage is present problem is in controller. Go to Test 2.
 - b. If low or no residual AC voltage is present, magnet in exciter stator may have lost its magnetism and the field needs to be flashed. Disconnect F1 and F2 wires from J6 connector in control box. Using a jumper wire connect F2 to GRD stud. Start genset. Using a jumper wire connect the F1 wire to J9 terminal or 12 Vdc. Check for AC voltage output on T1-T2, T1-T3, T2-T3, should be 400 VAC or higher. If AC voltage is present problem is in controller. Go to Test 2. If still no AC voltage problem is in alternator, go to Test 3 and Test 4.
 - c. If the unit has add on F1/F2 circuit board, remove the board and repeat step b. If AC voltage is now present replace the F1/F2 circuit board. If still no AC voltage problem is in alternator, go to Test 3 and Test 4.

Test 2 - Controller Excitation Test

1. Make sure unit is in the excite condition, J6 is connected and water temperature is above 32 C (90 F). Measure the voltage across the battery and record (12.5 Vdc).
2. Remove and check the 30 amp battery charger fuse S12. With the fuse removed from the controller start the unit and measure voltage at terminals J15 and J16 located under blue cap. See photos below. If the voltage is 16.1 to 16.8 Vdc, the controller is good. If voltage is the same as battery voltage, replace controller. Reinstall the battery fuse S12 and take the same readings at J15 and J16. If voltage reading is 16.1 to 16.8 Vdc, check the CH (10 ga) wire from J11 to the engine frame.

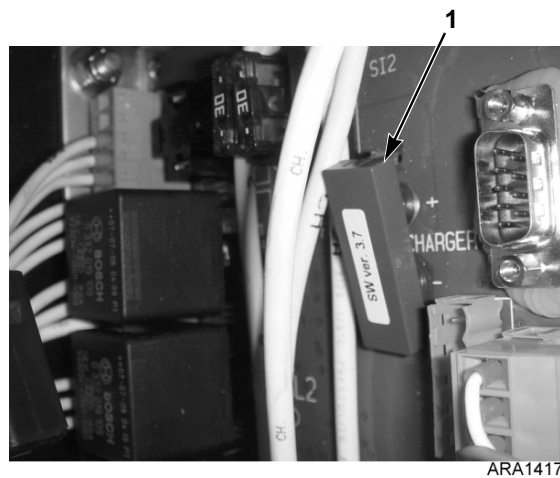

ARA1417

1.	Blue Cap
----	----------

Figure 93: Remove Blue Cap

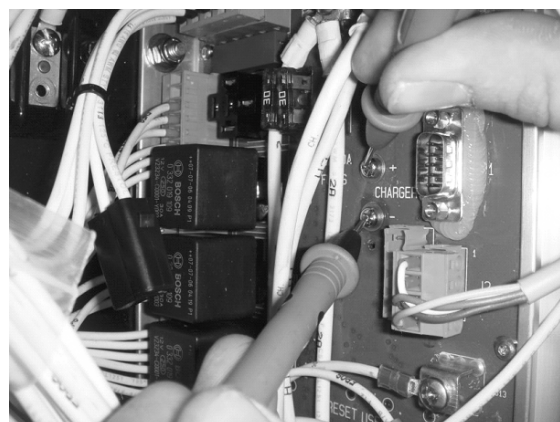

ARA1418

Figure 94: Check Voltage Between J15 and J16

Test 3 - Testing Alternator

1. Make sure software is 3.8.1 100325 or higher.
2. Connect J6 connector and water temperature sensor. Start unit, no load and water temperature >90° F.
3. Go to DATA MENU/ANALOG INPUTS and read the FIELD CURRENT. If higher than 0.5 Amps problem is in the alternator. Go to Test 4 and Test 5.

VOLTAGE MEAS.	460 V
FIELD CURRENT	1.1 A
WATER TEMP.	92 °C
RUNNING FREQ.	60Hz

Figure 95: DATA MENU/ANALOG INPUTS

Test 4 - Alternator Exciter Field Testing

1. Disconnect the field wire F1 and F2 from the J6 or at the plug in the control box. Measure the resistance of the field circuit (F1 to F2). The standard value is 13.9 (±10%) ohms at 77 F (25C). If field is open or resistance value is low replace exciter field 45-2301.
2. Measure F1 or F2 to GND for possible shorted to ground coils. Megger F1 to stator case to check for insulation break down, @ 500 Volts must be more than 1 M ohm.

Test 5 - Alternator Stator Testing

Test 5 covers testing the main alternator stator, the rotating rectifier, the rotating exciter field, and the rotating field armature.

1. Main alternator stator windings
 - a. Disconnect the stator leads from the terminal board and ground stud in the control box. Check for continuity between the following pairs. T1-T4, T2-T5, T3-T6, T7-T10, T8-T11, T9-T12. The resistance between any of the pairs should be 0.114 (±10%) ohms at 25 C (77 F).
 - b. Using a megger meter, check for insulation break down between each pair of leads to the stator case. @ 500 Volts must be more than 1 M ohm.

- c. Remove the end bell for the remaining checks

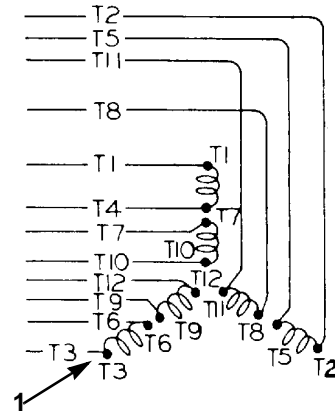

AJA2089

1.	Disconnect all 12 stator leads to test the stator.
----	--

Figure 96: Alternator Stator

2. Rotating Rectifier

Six rectifying diodes are mounted on the rotating exciter field, three are positive and three are negative.

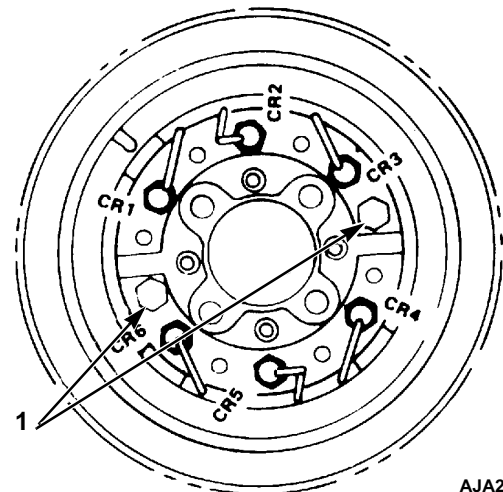

AJA2090

1.	Disconnect the main alternator field leads to test the diodes.
----	--

Figure 97: Rectifying Diodes

- a. Unbolt each of the exciter armature leads.
- b. Unbolt the main field armature leads. Along with the main field armature leads are leads to a MOV. The MOV is a high

voltage suppression device. When measured it will show open, it closes with peak voltage more than 600V cannot test.

- c. Check each diode in the forward and reverse direction. Good diode will have a high resistance reading in one direction and no reading when ohmmeter leads are reversed.

3. Rotating Exciter Armature

- a. With the armature leads still disconnected from the diodes, test between the following pairs of leads. CR6-CR4, CR3-CR1, CR3-CR2, CR6-CR5, CR5-CR4, CR2-CR1. The resistance between any of the pairs should be 0.645 ($\pm 10\%$) ohms at 25 C (77 F).
- b. Using a megger meter, check for insulation break down between each pair of leads to the rotor shaft. @ 500 Volts must be more than 1 M ohm.

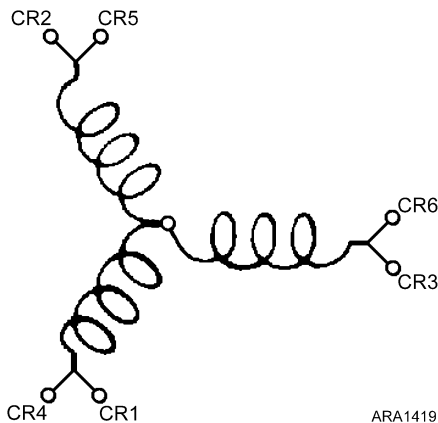
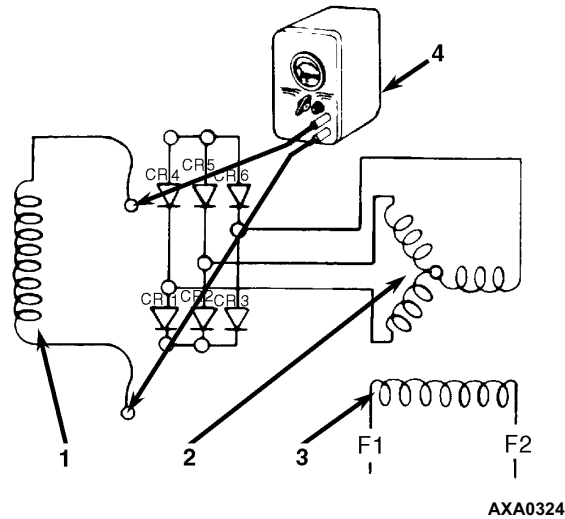

Figure 98: Exciter Armature

4. Rotating Field Armature

- a. Measure the resistance of the main field armature leads. The resistance should be 2.5 ($\pm 10\%$) ohms.
- b. Using a megger meter, check for insulation break down between the leads to the rotor shaft. @ 500 Volts must be more than 1 M ohm.



1.	Main Field
2.	Exciter Rotor
3.	Exciter Field
4.	Ohmmeter

Figure 99: Main Field Winding

Megohmmeter

The use of a megohmmeter can be a valuable addition to the repair and maintenance of the generator set. The megohmmeter is essentially a high-range resistance meter (ohmmeter) with a built-in direct-current generator. This meter is of special construction with both current and voltage coils-enabling true ohms to be read directly, independently of the actual voltage applied.

The meter gives you a direct reading of insulation resistance in “ohms” or “megohms” (1 megohm = 1,000,000 ohms). For good insulation, the resistance usually reads in the megohm range.

Normally, good insulation has high resistance; poor insulation, relatively low resistance. The actual resistance values can be higher or lower, depending upon such factors as the temperature or moisture content of the insulation (resistance decreases with increase in temperature or moisture). They can be quite different for a generator tested three days in a row, yet not mean bad insulation. What really matters is the trend in readings over a time period, showing lessening

resistance and warning of coming problems. Periodic testing is, therefore, your best approach to preventive maintenance.

Maintenance Procedures

The following paragraphs cover detailed maintenance procedures, including disassembly and assembly of equipment for necessary component removal and replacement. Many repair or replacement operations can be performed without extensive disassembly of the generator.



WARNING: DO NOT attempt adjustments or changes in wiring while a unit is in operation. The unit generates sufficient voltage to cause severe and possible fatal shock. Use extreme caution when operating in wet or damp locations.

General Inspection

Inspect the entire unit to see that controls are in order and that there are no loose nuts, bolts, electrical connections or fittings. Inspect for secure engine to generator mountings. Remove any waste material from area around the unit. Check battery connections.

Insulation

Inspect insulation on wires, coils and control components. See that insulation is not frayed, broken or deteriorated. Replace wire having damaged insulation.

Field Coils, Stator Windings

Visually inspect the field coils and stator windings, their leads and connections to determine if they are electrically and mechanically satisfactory. Look for any evidence of overheating, burned or frayed insulation, loose connections, foreign matter, etc.

Generator Housing

Feel the alternator housing cautiously for abnormal temperatures as determined by previous experience with the unit. If the generator is overheated, check the winding temperature with thermometer, locate the cause such as lack of

ventilation, overload, etc., and correct the condition or shut down the generator. Inspect the generator housing for obstruction of air passages.

Generator Bearing

All alternators covered in this manual are fitted with a permanently lubricated bearing which requires no maintenance in normal service.

Impeller Fan

Visually inspect the impeller fan to ascertain that no vanes are missing. Visually inspect the fan is not encrusted with dirt or other foreign matter to the point where it will not function properly.

Coupling

Disc type coupling. Inspect to see that coupling bolts are tight and that the generator is solidly secured to the engine.

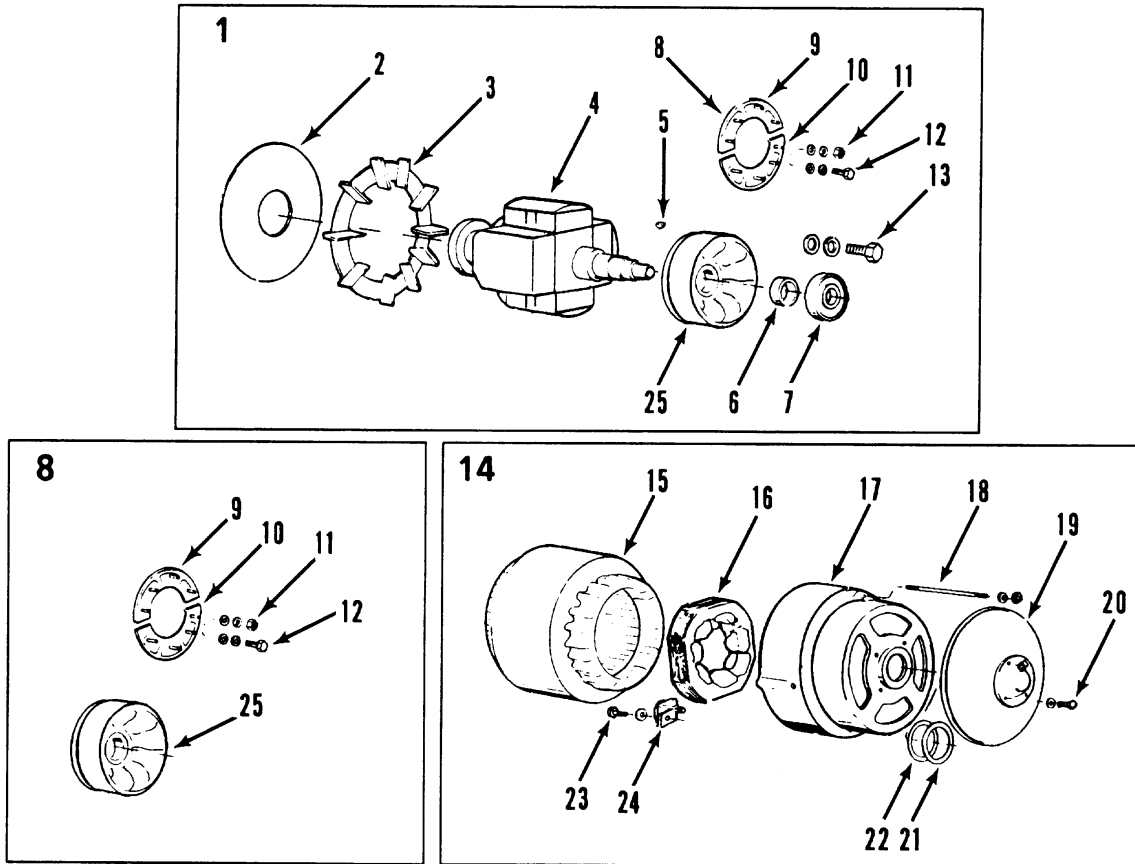

AXA0325

1.	Rotor Assembly	14.	Stator and End Bell Assembly
2.	Disc, Rotor Drive	15.	Stator, Wound
3.	Blower, Generator	16.	Exciter, Field
4.	Rotor	17.	Bell, End
5.	Key	18.	Stud, Bell
6.	Spacer, Bearing	19.	Cover, End Bell
7.	Bearing/Seal, Rotor	20.	Screw, Mounting End Bell Cover
8.	Exciter Assembly, Rotor	21.	Gasket, End Bell Cover
9.	Rectifier, Positive Assembly	22.	O-ring
10.	Rectifier, Negative Assembly	23.	Screw, Retainer
11.	Nut, Rectifier Assembly	24.	Retainer, Exciter
12.	Screw, Mounting Rectifier	25.	Rotor
13.	Screw, Mounting Bearing		

Figure 100: Alternator Assembly

Rewiring Procedures for Changing the Generator Set Output Voltage

The alternator stator features a 12 lead design that contains two separate windings for each of the three output phases. The 12 leads are numbered T1 through T12. All rewiring is performed inside the control box.

All generator sets are factory wired for 460 Vac power output. 460 Vac operation requires that the two individual windings in each of the three phases be connected in series: T4 tied to T7, T5 tied to T8, and T6 tied to T9. The three output phases are:

Phase	Wires
A (Black)	T1
B (White)	T2
C (Red)	T3

230 Vac operation requires that one of the two windings in each of the three phases be connected in parallel: T4, T5, and T6 are tied together. The three output phases are:

Phase	Wires
A (Black)	T1, T7 (tied together)
B (White)	T2, T8 (tied together)
C (Red)	T3, T9 (tied together)

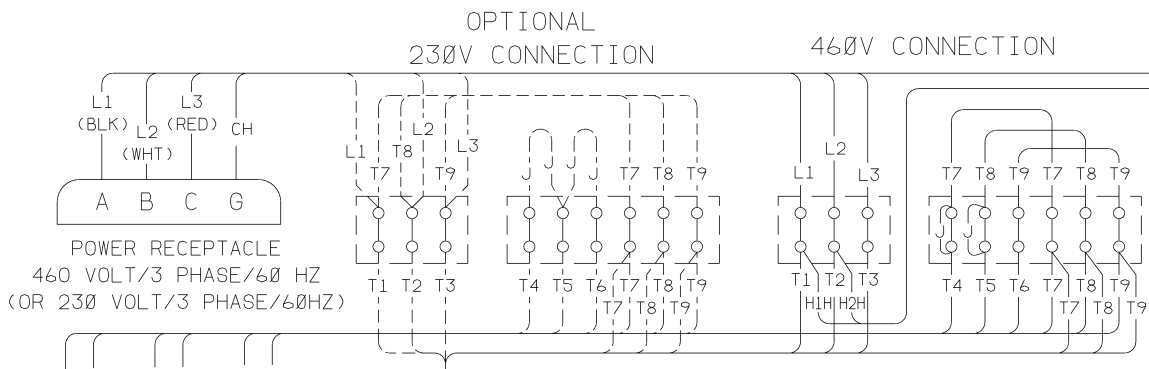

Figure 101: Changing Output Voltage

Rewiring Procedure for Changing the Output Voltage from 460 Vac to 230 Vac

⚠ WARNING: Disconnect the unit battery to prevent the unit from accidentally starting during rewiring.

- Refer to the unit wiring diagram for illustrations of the proper wire connections.
- Disconnect Wires:
 - Remove wire T7 from T4 connection, wire T8 from T5 connection and wire T9 from T6 connection on the main output terminal block.
 - Remove jumper wires on the terminal block from the T4 connection and T5 connection.
- Reconnect Wires:
 - Install wire T7 lead on L1 (Black Wire) terminal, wire T8 on L2 (White Wire) terminal and wire T9 lead on L3 (Red Wire) terminal.
 - Connect T4 jumper wire lead to J5 wire terminal. Connect T5 jumper wire lead to J6 wire terminal.
- Change output receptacle to 230 Vac.
- Change voltage decal and nameplate markings from 460 Vac to 230 Vac.
- Use the Configuration Menu to change the Output Voltage setting from 460 to 230. See “Configuration Menu” on page 69.

Structural/Accessory Maintenance

Unit Inspection

Inspect the unit during unit pre-trip inspection and scheduled maintenance intervals. Look for loose or broken wires or hardware, and other physical damage which might affect unit performance. Repair if required.

NOTE: See Service Guide chapter in this manual for the correct service interval for your unit. 250 or 500 hour inspection/service intervals are required in extreme operating conditions.

Mounting Bolts

Check and tighten all engine and control box mounting bolts every 1,000 operating hours. Unit mounting hardware should be inspected for tightness during every pretrip.

Mounting Bolt	Torque
SGCO Units:	
Upper Clamp	Lock clamp with lock pawl
Lower Mounting Bolts	300 to 380 N.m (220 to 280 ft-lb)
All Units:	
TK486 Engine	203 N.m (150 ft-lb)
Exciter Control Box	20 to 27 N.m (15 to 20 ft-lb)
Power Cord Receptacle	20 to 27 N.m (15 to 20 ft-lb)
Fuel Tank	81 to 88 N.m (60 to 65 ft-lb)

Radiator Fan Location

The radiator fan and hub assembly mounts on the water pump pulley. When installed, the fan blade should be in the orifice with 65 to 70 percent of the blade width to the air discharge side for proper fan performance.

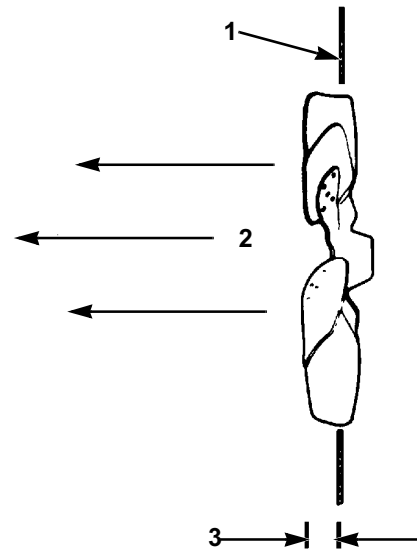

AJA2092

1.	Radiator Coil Orifice
2.	Airflow Direction
3.	65 to 70 Percent of Fan Blade Depth to Air Discharge Side of Orifice

Figure 102: Radiator Fan Blade Placement

SGCO 3000 Clip-on Corner Clamp Unit Installation

1. Pull the lock pawl handle forward. Lift the clamp handle to rotate the clamp shaft 90 Degrees.

2. Lift the unit into mounting position on front wall of the container. The foot of generator set mounting clamp should fit into mounting hole on each side of the container.

CAUTION: Take adequate precautions when lifting and mounting the generator set to prevent personal injury or unit damage.

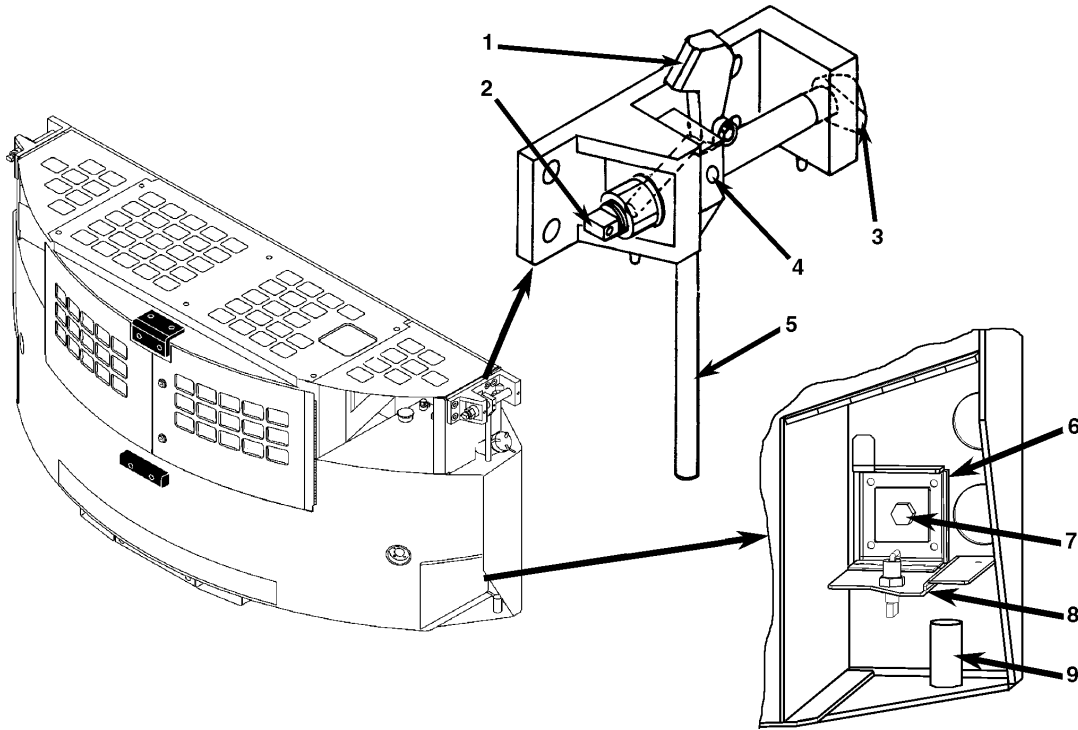

AXA0331

1.	Lock Pawl	6.	Mounting Bolt Retainer Assembly
2.	Mounting Clamp Flat	7.	Mounting Bolt
3.	Handle	8.	Retainer Door with Latch
4.	Shoulder Screw	9.	Bolt Holder Tube
5.	Mounting Clamp Foot		

Figure 103: SGCO 3000 Clip-on Corner Clamp Installation

3. Insert the foot of the mounting clamp fully into the container mounting hole. Pull lock pawl handle forward. Pull the clamp handle down to rotate the clamp shaft bolt 90° and clamp generator set to container.

⚠ CAUTION: Watch the clamp flat on threaded end of the mounting shaft when rotating the handle. The clamp flat should turn as the clamp handle rotates. With the mounting clamp in the locked position (handle down), the clamp flat must be horizontal. If the flat is not horizontal, check the clamp handle for a broken shoulder screw.

4. Release the lock pawl to hold the clamp handle in the locked (down) position.

⚠ CAUTION: Excessive vibration or unit malfunction can occur if mounting clamps are not properly secured. The generator set MUST be tight against the container.

5. Check to be sure the generator set frame fits tightly against the container. Turning the mounting clamp handle should pull the generator set frame tight against the container front wall. If necessary, tighten the mounting clamp. The mounting clamp can be tightened or loosened by turning the nut on the head of the clamp shaft.

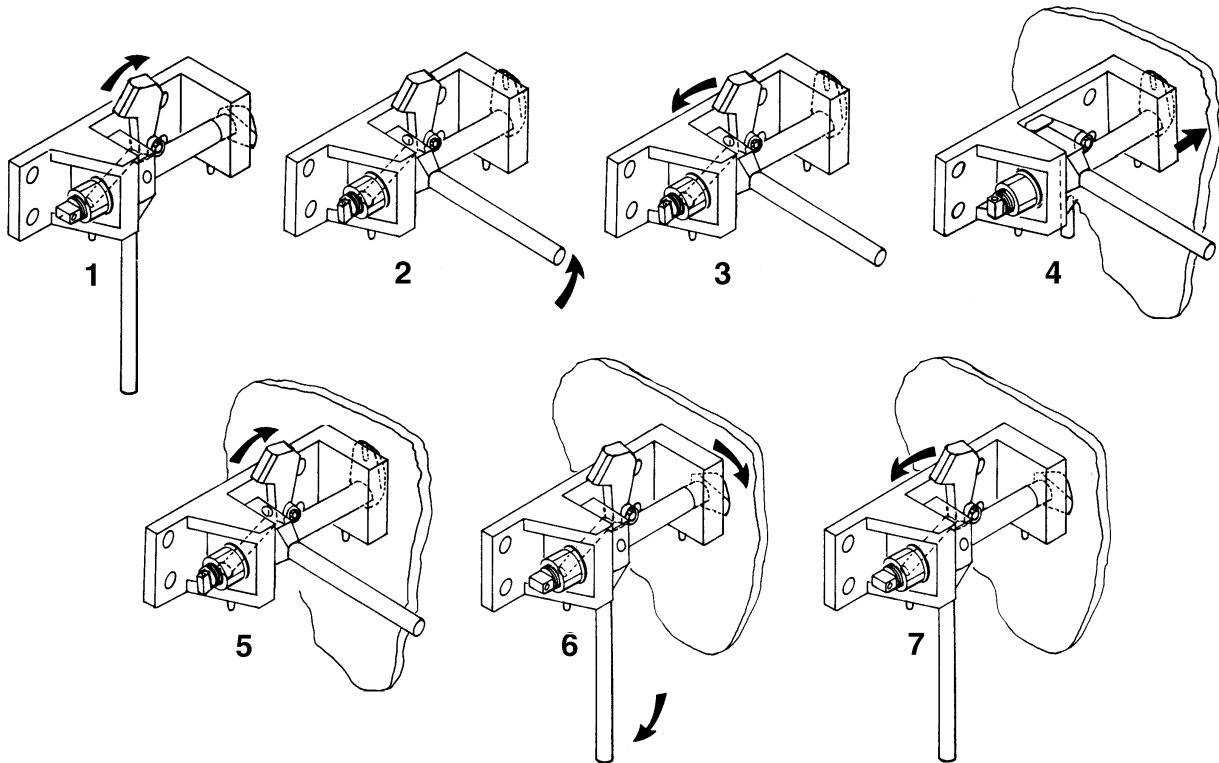

AXA0332

1.	Lift (Unlock) Lock Pawl	5.	Lift (Unlock) Lock Pawl
2.	Rotate Clamp Handle Up 90 degrees	6.	Rotate Clamp Handle Down 90 degrees
3.	Release (Lower) Lock Pawl	7.	Release (Lower) Lock Pawl
4.	Insert Mounting Clamp Foot in Container Mounting Hole	8.	

Figure 104: SGC0 3000 Clip-on Corner Clamp Installation Procedure

6. Install the lower mounting bolts:
 - a. Remove the retaining pin from the lower mounting bracket.
 - b. Remove the mounting bolt and backup plate from the keeper nut. Put the mounting bolt through the backup plate and install the bolt in the mounting hole.
 - c. Tighten the lower mounting bolts to 300 to 380 N.m (220 to 280 ft-lb).
 - d. Install the retaining pin and hair pin key to prevent accidental loss of the mounting bolt and backup plate during unit operation.

SGCO 3000 Clip-on Header Pin Unit Installation

1. Lift the unit into mounting position on front wall of the container. Both header pins of generator set mounting channel should fit into mounting holes on top of the container.

⚠ CAUTION: Take adequate precautions when lifting and mounting the generator set to prevent personal injury or unit damage.

2. Check to be sure the generator set frame fits tightly against the container.

⚠ CAUTION: Excessive vibration or unit malfunction can occur if mounting clamps are not properly secured. The generator set **MUST** be tight against the container.

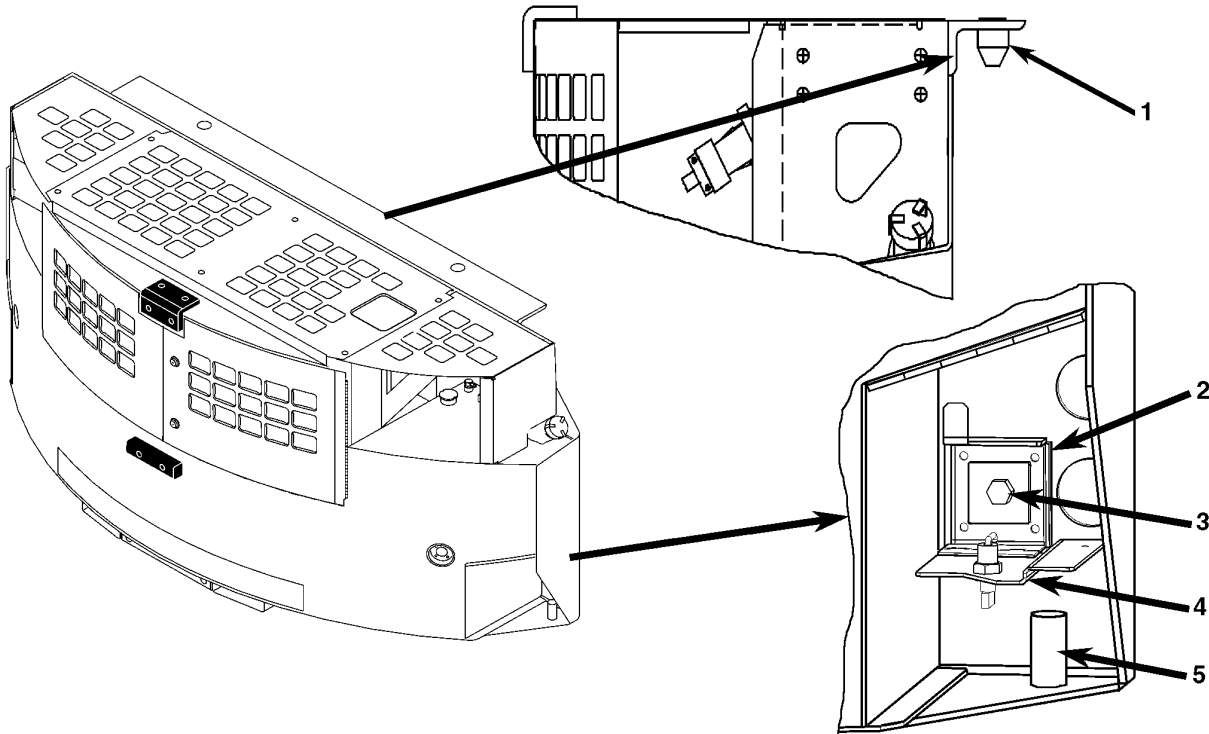

AXA0333

1.	Header Pin	4.	Retainer Door with Latch
2.	Mounting Bolt Retainer Assembly	5.	Bolt Holder Tube
3.	Mounting Bolt		

Figure 105: SGCO Clip-on Header Pin Mounting Installation

3. Install the lower mounting bolts:
 - a. Remove the retaining pin from the lower mounting bracket.
 - b. Remove the mounting bolt and backup plate from the keeper nut. Put the mounting bolt through the backup plate and install the bolt in the mounting hole.
 - c. Tighten the lower mounting bolts to 203 N.m (150 ft-lb).
 - d. Install the retaining pin and hair pin key to prevent accidental loss of the mounting bolt and backup plate during unit operation.

Unit Inspection

Inspect the unit during unit pre-trip inspection and scheduled maintenance intervals. Look for loose or broken wires or hardware, and other physical damage which might affect unit performance. Repair if required.

NOTE: See Service Guide chapter in this manual for the correct service interval for your unit. 250 or 500 hour inspection/service intervals are required in extreme operating conditions.

Radiator Coil

Clean the radiator every 1,000 operating hours. Blow compressed air from the outside of the coil in toward the condenser fan to clean coil (the direction opposite the normal air flow). Inspect the coil and fins for damage and repair if necessary.



CAUTION: Air pressure should not be high enough to damage coil fins.

Mechanical Diagnosis

NOTE: This diagnosis guide applies to units equipped with TK486 engines. For major repair of TK486 engines, refer to Overhaul Manual, TK 50136.

Diagnosing Unit Conditions

Condition	Possible Cause	Remedy
Unit switch On; controller display does not come on	Corroded battery cable connections Batteries discharged Fuse SI3 open (blown) Defective On/Off switch Open circuit	Clean and tighten Charge or replace batteries Check for short circuit and replace fuse Check switch Check 2, 2B, 2C and 8 circuits
Unit switch On (controller display is On) but engine does not crank	Batteries discharged Corroded battery connections Defective starter relay or open circuit Defective starter solenoid Defective starter Water in cylinders	Charge or replace battery Clean and tighten Replace relay; check 2A, 8S, SR and PSR circuits Replace solenoid Repair starter Check for hydrostatic lock. Remove injectors and turn engine slowly
Starter motor turns but engine does not crank	Starter clutch defective	Replace
Engine cranks but fails to start	Fuel solenoid not energized Fuel solenoid valve defective or stuck No fuel or wrong fuel Air cleaner clogged Exhaust plugged Air heater defective Air in fuel system Fuel pump defective Incorrect timing Injection nozzles defective Injection pump defective Compression low	Check fuse SI1, 8D and 8DP circuits, fuel pull relay (RL1), and fuel hold relay (RL2). Replace Fill with proper fuel Clean and refill oil reservoir on oil bath air cleaner; or replace dry air cleaner filter Clear exhaust system Replace defective air heater Bleed air Replace pump Adjust timing Repair or replace nozzles Replace pump Overhaul engine

Diagnosing Unit Conditions

Condition	Possible Cause	Remedy
Engine stops after starting	Alarm LED flashing Vent of fuel tank obstructed Fuel filter obstructed Clogged fuel tank or fuel lines Air in injection pump	Check alarm code and repair fault (see "Alarm List" on page 52) Unclog vent Replace filter element Clean fuel tank and fuel lines Bleed fuel system
Engine does not develop full power	Air cleaner or intake system clogged Fuel tank vent clogged Clogged fuel tank or fuel lines Speed adjustment wrong Insufficient fuel volume leaving filter(s) Injection pump timing off Nozzles defective Delivery of fuel pump insufficient Worn injection pump plungers, delivery valve defective, injection rate too low, gum formations Compression low or unbalanced	Clean air intake system; clean and refill oil reservoir on oil bath air cleaner; or replace dry air cleaner filter Unclog vent Clean fuel tank and fuel lines Adjust speed Check for dirty filter or air in system Adjust timing Repair or replace nozzles Repair pump Repair or replace pump Overhaul engine
Engine knocks heavily	Wrong fuel Air in system Fuel return line plugged Injection nozzles fouled or opening pressure too low Valve out of adjustment Delivery valve spring broken Injection pump not timed Compression too low Rod or main bearing worn	Change fuel Bleed fuel system Remove return line restriction Clean, repair or replace injection nozzles Adjust valves Replace spring or repair injection pump Retime injection pump Overhaul engine Replace rod or main bearings
Engine speed too high	Mis-adjusted speed screw Control rod sticks	Adjust speed screw Repair injection pump
Engine fails to stop when unit is Off	Fuel solenoid defective Injection pump defective	Replace solenoid Replace pump

Diagnosing Unit Conditions

Condition	Possible Cause	Remedy
Engine runs hot	Coolant level is low Loose or worn water pump belt Generator overloaded Dirty radiator Defective thermostat Cooling system heavily scaled Cylinder head gasket leaks	Add coolant Replace belt Check load Wash radiator Check or replace thermostat Clean cooling system Replace cylinder head gasket. Use correct gasket
Oil pressure too low or drops suddenly. Minimum oil pressure for a hot engine is 117 kPa, 1.17 bar, 17 psi (low oil pressure switch setting)	Insufficient oil in pan Defective oil pressure sensor Oil relief valve sticking Worn oil pump, camshaft, main or connecting rod bearings, loose oil gallery plug	Add oil Check oil line to oil pressure sensor to see if it is blocked. Check oil pressure sensor. Replace if necessary Disassemble and clean oil pressure regulator valve Repair engine
High oil consumption	Oil leakage Clogged air cleaner system Clogged crankcase breather Damaged valve seals Worn valve stem Poor compression Broken piston rings or cylinder bore worn or scored	Check and eliminate possible causes at cylinder head cover, oil lines, oil filter, front timing cover or crankshaft seals Clean air intake system; clean and refill oil reservoir on oil bath air cleaner; or replace dry air cleaner filter Clean breather system Replace seals on valve stem Replace valves Check and eliminate possible causes. Repair as necessary Have engine repaired and re-bored. Replace broken piston rings
Battery is not recharging system charging system	Loose connections in electrical system Battery defective Air heater does not shut off Controller defective	Check all electrical connections and charging system Replace battery Check preheat relay and preheat circuit Replace controller

Diagnosing Unit Conditions

Condition	Possible Cause	Remedy
White Smoke (fuel is not burning)	Cold engine Air or water in fuel Insufficient preheat Low compression Timing incorrect Injection pump defective	Allow engine to warm up Bleed system. Replace filters, clean fuel system, drain and clean tank and check supply tank for water. Use known good fuel Check air heater Check and eliminate possible causes. Repair as necessary Readjust timing Replace or repair pump
Blue Smoke (oil consumption)	Excessive oil consumption	Refer to High Oil Consumption. Repair as necessary
Black Smoke (excessive fuel to air ratio) • Engine is sooting heavily, emits thick black clouds of smoke	Cold engine Wrong fuel Clogged air intake system Restricted exhaust system Oil being drawn in Excessive load Injection pump not timed Opening pressure of nozzle is too low or needle sticks Injection amount too great Poor compression	Allow engine to warm up Drain and refill with correct fuel Clean or replace air cleaner Clean or replace Check oil level in oil bath air filter Check drive system and engine oil pressure Check timing of injection pump Repair nozzle. Replace if necessary Have pump repaired Check and eliminate possible causes. Repair as necessary

Index

A

- Additional Options 29
- After Start Inspection 43
- Air Cleaner, Cyclonic Dry 90
- Air Heater 81
- Air Restriction Indicator 90
- Alarm Diagnosis 51
- Alarm List Menu 39, 51
- Alarm Types 51
- Alarms, Displaying and Acknowledging 51
- Alternator Assembly Drawings 122
- Alternator Tests
 - Test 2 118
 - Test 3 119
 - Test 4 119
 - Test 5 119
 - Test No. 1 118
- Alternator, Diagnosis 117
- Alternator, Function of 116
- Alternator, General Description 115
- Alternator, Rewiring Procedures 123
- Alternator, wiring for Dual Voltage 115
- Analog Inputs 47
- Antifreeze Maintenance Procedure 93
- Antifreeze, Change 93
- Antifreeze, Check 93

B

- Battery 79
- Battery Hazards 15
- Belt Replacement 113
- Belt Tension Adjustment 113
- Bleeding Air from the Cooling System 94
- Bleeding the Fuel System 97

C

- C/F Mode 66
- Charging System, Battery 12 vdc 80
- Coil, Radiator 129
- Cold Start Device 109
- Commands Menu 39, 58
- Configuration Menu 39, 69
- Controller Display Menus 37
- Controller Overview 35
- Controller Repair 17
- Coolant Level Detector 84
- Coolant Level Detector Sensor Test 84
- Coolant Temperature Sensor 83
- Cooling System, Bleeding Air from 94
- Cooling System, Engine 91
- Crankcase Breather 89
- Cyclonic Dry Air Cleaner 90

D

- Data Menu 39, 46
- Date/Time 64
- Decals
 - SGCO 20

- Decals, Units 20
- Description, General 27
- Diagnosis, Mechanical 131
- Diagram, Menu Flow 139
- Diagram, Schematic 139
- Diagram, Wiring 139
- Digital Inputs 48
- Digital Outputs 49
- Displaying and Acknowledging Alarms 51
- Displaying and Acknowledging Messages 54
- Dual Voltage Option 29

E

- EcoPower Option 29
- ELC (Extended Life Coolant) 91
- Electrical Maintenance 79
- Electrical Diagrams 139
- Electrical Hazards 15
- Electrical Maintenance 79
- EMI 3000 87
- EMI 3000 Package 28
- Engine Cooling System 91
- Engine Fuel System 95
- Engine Low Oil Pressure Switch 81
- Engine Speed Adjustment 99
- Engine Thermostat 95
- Engine Valve Clearance Adjustment 111
- Engine, Serial Number Locations 19
- Event Log 74
- Event Log Menu 39, 73

F

- Fan Location, Radiator 125
- Features, Genset Model 13
- First Aid 15, 16
- Flywheel Sensor 85
- Flywheel Sensor Test 85
- Front View
 - Powerpack 31
 - SGCO 30
- Fuel Events 74
- Fuel Filter Replacement 98
- Fuel Hold Relay 79
- Fuel Pull Relay 79
- Fuel Return Line Replacement 97
- Fuel Solenoid 100
 - Diagnosis 100
 - Introduction 100
 - Replacement 102
- Fuel Strainer 98
- Fuel System, Bleeding 97
- Fuel System, Engine 95
- Fuel System, Water in the 98
- Functional Inspection 43

G

- Generator, Serial Number Locations 19
- Genset

Model Features 13
Genset Model Features 13

H

High Voltage 15
HM1 Threshold 72
HM2 Threshold 72
Hour Meter Thresholds, Setting 72

I

Injection Pump
 Installation 104
 Removal 103
 Timing 105
Inspection of Unit 125, 129
Inspection, After Start 43
Installation, SGCO 3000 Clip-on Corner Clamp Unit
 126
Installation, SGCO 3000 Clip-on Header Pin Unit 128
Internal States 50

L

LogView 76
Low Oil Pressure 88
Low Oil Pressure Switch, Description 29
Low Voltage 16
Lubrication System, Engine 87

M

Main Menu 45
Maintenance Procedures 121
Manual Function Test 60
Mechanical Diagnosis 131
Megohmmeter 120
Menu Flow Diagrams 139
Menu Overview 38
Menus 37
 Navigating 37
Message Diagnosis 54
Message List Menu 39, 54
Microprocessor, Description 33
Misc. Functions Menu 39, 65
Model Features, Genset 13
Mounting Bolts, Torque Values 125

N

Navigating Controller Menus 37

O

Oil Change, Engine 87
Oil Filter Change, Engine 87
Oil Level Sensor 82
Oil Level Sensor Switch Test 82
Oil Level Sensor, Description 29

P

Precautions 16
Pretrip Inspection 41
Pretrip Inspection Test 43, 59

Protection Devices, Descriptions 29
PTI (Pretrip Inspection Test) 43, 59

R

Radiator Coil 129
Radiator Fan Location 125
Recover Refrigerant 3
Refrigerant Recovery 3
Relays 79

S

Safety 17
Safety Do's and Don'ts 17
Safety Instructions
 Battery Hazards 15
 Controller Repair 17
 Electrical Hazards 15
 First Aid 15, 16
 High Voltage 15
 Low Voltage 16
 Precautions 16
 Safety Do's and Don'ts 17
 Welding 17
Safety Precautions 15
Schematic Diagrams 139
Sensor Test Sensor Test 83
Serial 19
Serial Number Locations 19
 Engine 19
 Generator 19
 SGCO Units 19
Service Guide 21
Setting Hour Meter Thresholds 72
SG+ Controller Description 33
SGCO 3000 Clip-on Corner Clamp Unit Installation 126
SGCO 3000 Clip-on Header Pin Unit Installation 128
SGCO 3000 Genset Addendum 11
SGCO Units, Serial Number Locations 19
Specifications 23
 Controller Default Settings 24
 Electrical Components 24
 Electrical Control System 24
 Engine 23
 Generator 23
 Metric Hardware Torque Charts 26
Speed (Throttle) Solenoid Relay 79
Speed Adjustment, Engine 99
Standard Display 40
Starting the Unit 42
SW/HW Version 67
System Setup 62

T

Thermostat, Engine 95
Throttle (Speed) Solenoid Relay 79
Timers/Counters 68
Torque Values, Mounting Bolts 125
Trochoid Feed Pump 108

U

Unit Controls, Descriptions 35
Unit Decals 20
Unit Inspection 125, 129
Unit Instruments, Descriptions 28

V

Valve Clearance Adjustment 111
Viewing SG+ Logs 76

W

Water in the Fuel System 98
Water Separator Replacement 98
Water Temperature Sensor, Description 29
Welding 17
Wiring Diagrams 139

Electrical and SG+ Menu Flow Diagrams

Drawing Title	Page
Wiring Diagram Genset SG+	141
Schematic Diagram Genset SG+	142
SG+ Menu Flow Diagram	143-144

SGCO 3000 Wiring Diagram — Page 1 of 1

REVISIONS				
CHANGE ORDER	REV	DESCRIPTION	DATE	APPROVED
508345	A	RELEASED	06-Apr-06	RB
514075	B	UPDATED WIRING DIAGRAM	14-Nov-06	RB
514862	C	ADDED THROTTLE SOLENOID	19-Apr-07	RB
516070	D	ADDED FUEL LEVEL SENSOR	18-May-07	RB
516523	E	ADDED DOWNLOAD PORT	09-Jul-07	RB
521249	F	REMOVED 3 TERM BOARD	28-Feb-08	RB
537295	G	WIRE FNEG WAS ON J1 PIN 16, FPOS WAS CONNECTED TO J12, ON J4: PIN 1 WAS SR, PIN 2 WAS PSR, PIN 4 WAS PHR, PIN 5 WAS PPHR, UPDATE ALTERNATOR FIGURE.	25-Sep-09	RB

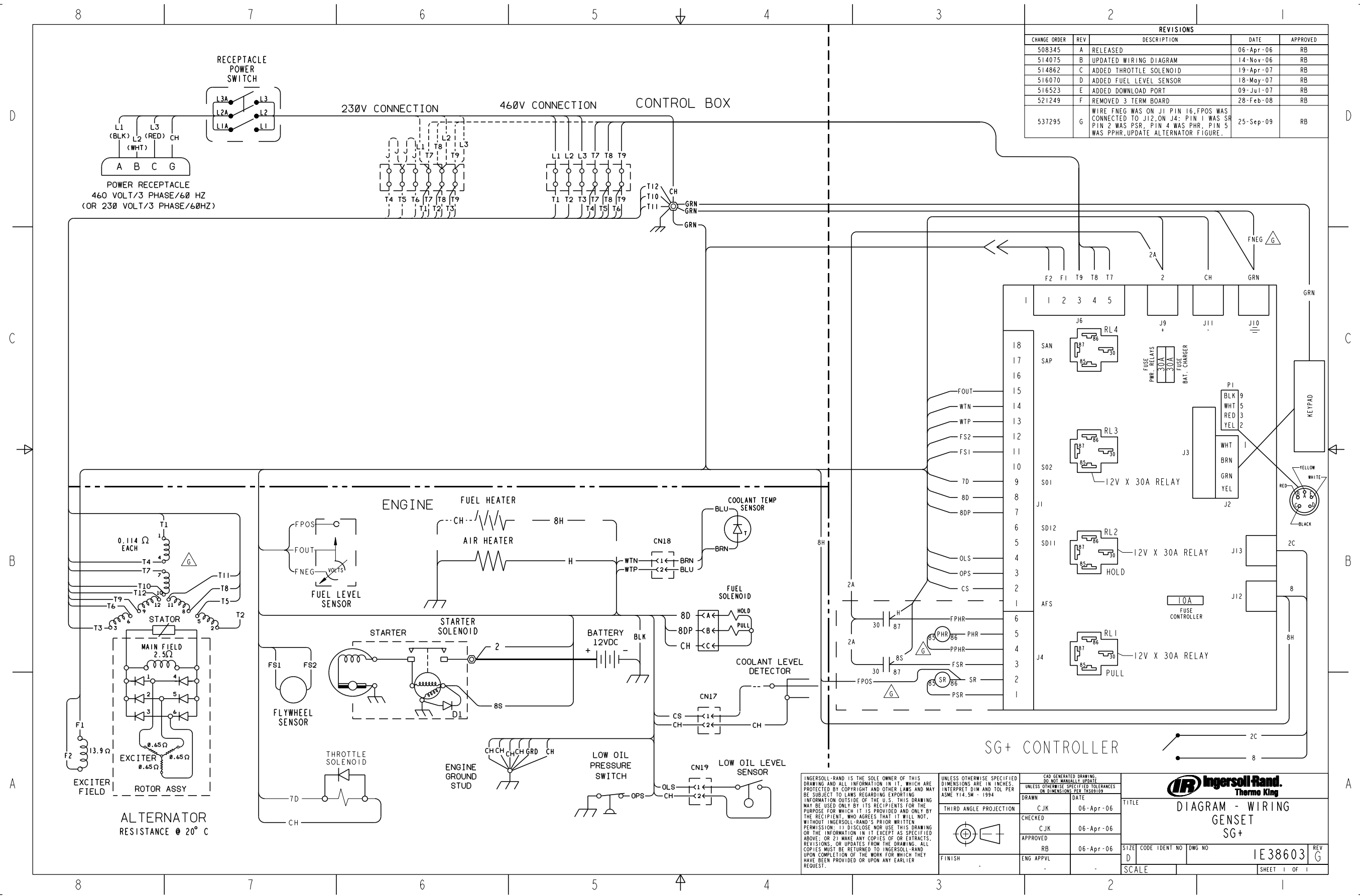

INGERSOLL-RAND IS THE SOLE OWNER OF THIS DRAWING AND ALL INFORMATION IN IT, WHICH ARE PROTECTED BY COPYRIGHT AND OTHER LAWS AND MAY BE SUBJECT TO LAWS REGARDING EXPORTING INFORMATION OUTSIDE OF THE U.S. THIS DRAWING MAY BE USED ONLY BY ITS RECIPIENTS FOR THE PURPOSE FOR WHICH IT IS PROVIDED AND ONLY BY THE RECIPIENT, WHO AGREES THAT IT WILL NOT, WITHOUT INGERSOLL-RAND'S PRIOR WRITTEN PERMISSION, DISCLOSE NOR USE THIS DRAWING OR THE INFORMATION IN IT EXCEPT AS SPECIFIED ABOVE, OR MAKE ANY COPIES OF OR EXTRACTS, REVISIONS, OR UPDATES FROM THE DRAWING. ALL COPIES MUST BE RETURNED TO INGERSOLL-RAND UPON COMPLETION OF THE WORK FOR WHICH THEY HAVE BEEN PROVIDED OR UPON ANY EARLIER REQUEST.

UNLESS OTHERWISE SPECIFIED DIMENSIONS ARE IN INCHES. INTERPRET DIM AND TOL PER ASME Y14.5M - 1994	CAD GENERATED DRAWING. DO NOT MANUALLY UPDATE UNLESS OTHERWISE SPECIFIED TOLERANCES OR DIMENSIONS PER TSD80109	DATE	TITLE
THIRD ANGLE PROJECTION	DRAWN	06-Apr-06	DIAGRAM - WIRING GENSET SG+
CHECKED	CJK	06-Apr-06	SIZE CODE IDENT NO DWG NO
APPROVED	RB	06-Apr-06	D I E38603 REV G
FINISH	ENG APPLV		SCALE SHEET 1 OF 1

Ingersoll-Rand Thermo King

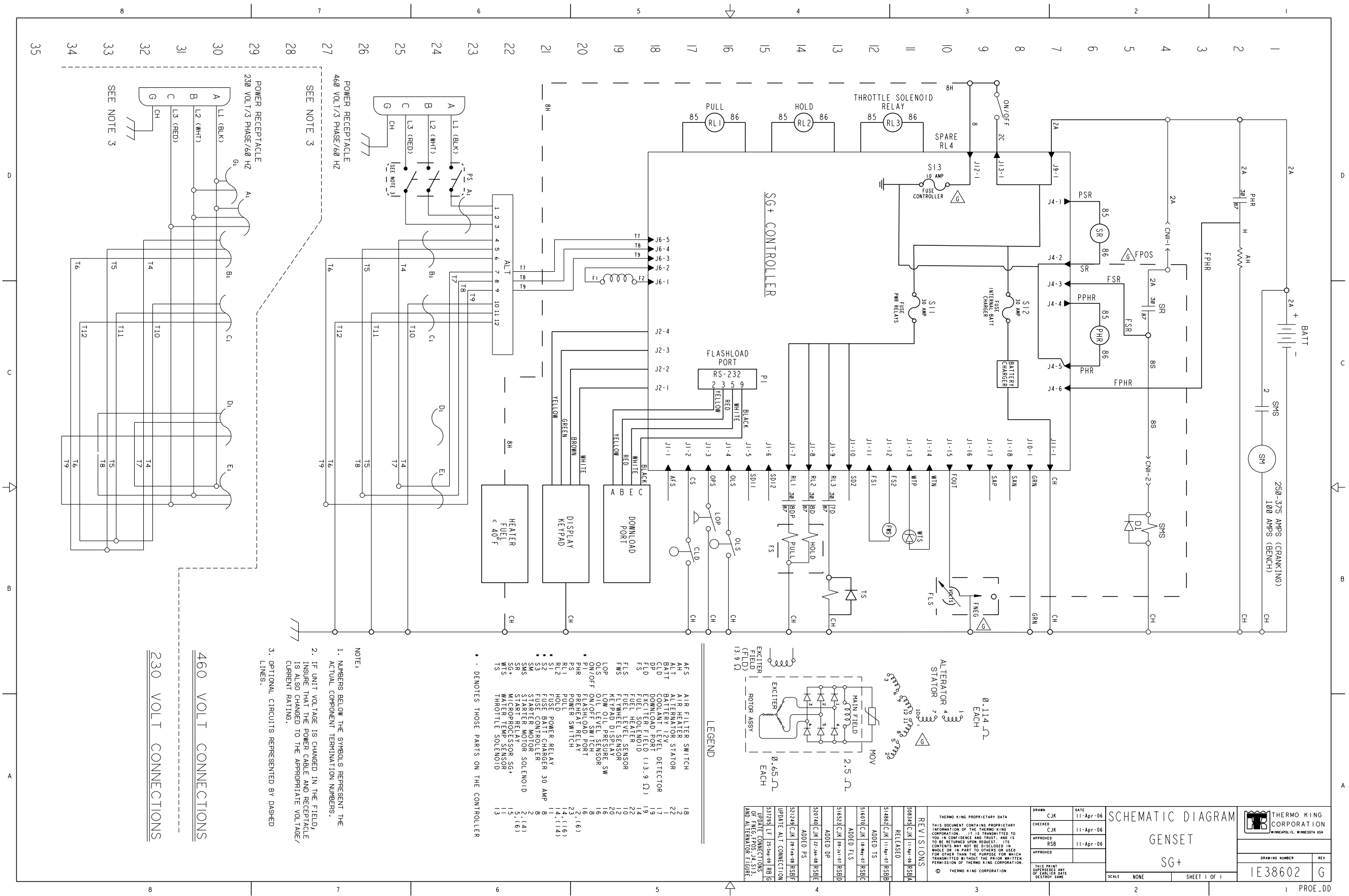

POWER RECEPTACLE
230 VOLT/3 PHASE/60 HZ

POWER RECEPTACLE
460 VOLT/3 PHASE/60 HZ

SEE NOTE 3

NOTE:
1. NUMBERS BELOW THE SYMBOLS REPRESENT THE ACTUAL COMPONENT TERMINATION NUMBERS.
2. IF UNIT VOLTAGE IS CHANGED IN THE FIELD, INSURE THAT THE POWER CABLE AND RECEPTACLE IS ALSO CHANGED TO THE APPROPRIATE VOLTAGE/CURRENT RATING.
3. OPTIONAL CIRCUITS REPRESENTED BY DASHED LINES.

460 VOLT CONNECTIONS

230 VOLT CONNECTIONS

• - DENOTES THOSE PARTS ON THE CONTROLLER

LEGEND

AFS	AIR FILTER SWITCH	18
AH	AIR HEATER	22
ALT	ALTERNATOR STATOR	22
BATT	BATTERY	11
BLD	BATTERY LEVEL DETECTOR	19
DP	DOWNLOAD PORT	19
FLD	EXCITER FIELD (13.9 Ω)	14
FS	FUEL SOLENOID	22
FHS	FUEL HEATER SENSOR	20
FWS	FUEL WHEEL SENSOR	12
KDP	KEYPAD DISPLAY	16
LOP	LOW OIL PRESSURE SW	16
ON/OFF	ON/OFF SWITCH	8
PI	PREHEAT RELAY	16
PHR	POWER HEATER	23 (16)
PS	POWER SWITCH	11
RL1	FUSE BATT CHARGER 30 AMP	8
RL2	FUSE BATT CHARGER 30 AMP	8
RL3	FUSE BATT CHARGER 30 AMP	8
RL4	FUSE BATT CHARGER 30 AMP	8
RS	STARTER MOTOR SOLENOID	2 (14)
SMS	STARTER MOTOR SOLENOID	5 (16)
SG+	SG+ CONTROLLER	15
WIS	WATER TEMPERATURE SENSOR	15
TS	THROTTLE SOLENOID	13

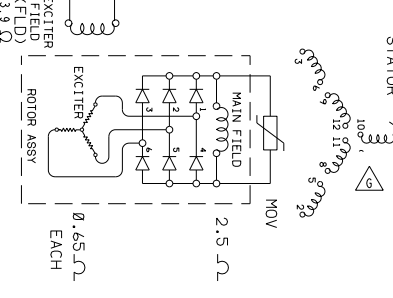

THERMO KING PROPRIETARY DATA THIS DOCUMENT CONTAINS PROPRIETARY INFORMATION OF THE THERMO KING CORPORATION. IT IS TRANSMITTED TO YOU IN CONFIDENCE AND TRUST, AND IS TO BE RETURNED TO THE THERMO KING CORPORATION WITH THE PROCEEDINGS IN WHICH TRANSMITTED WITHOUT THE PRIOR WRITTEN PERMISSION OF THERMO KING CORPORATION.		DRAWN: CJK CHECKED: CJK APPROVED: RSB DATE: 11-Apr-06 DATE: 11-Apr-06 DATE: 11-Apr-06	SCHEMATIC DIAGRAM GENSET SG+	THERMO KING CORPORATION MINNEAPOLIS, MINNESOTA USA
REVISIONS 51834d C/M (11-4v-04) R5BA 51846g C/M (11-4v-04) R5DB 51601g C/M (14-4v-04) R5BC 51652j C/M (14-4v-04) R5BD 52074d C/M (21-4v-04) R5BE 52124g C/M (24-4v-04) R5BF 53728j LT (25-4v-04) R5B 53728j LT (25-4v-04) R5B	DATE: 11-Apr-06 DATE: 11-Apr-06 DATE: 11-Apr-06	SHEET 1 OF 1	DRAWING NUMBER: IE38602 REV: G	SCALE: NONE



ARA979

Keypad Operating Tips

Text Input:

- To enter a number: Press the **UP** or **DOWN** key to increase or decrease the value of a digit in the display.
- Press the **ENTER** key to scroll the cursor to the right.

To Enter a Controller Menu or Submenu:

- Press **ALARM** key to directly enter the Alarm List Menu.
- Press the **ENTER** key or the **ESCAPE** key to enter the Main Menu.
- Press **ENTER** key to enter a menu from the Main Menu, or a submenu from its parent menu.
- Press **ESCAPE** key to return to the Main Menu from a menu, or a menu from a submenu.

To Scroll in a menu:

- Press **UP** key to scroll up.
- Press **DOWN** key to scroll down.

To Enter a Command or execute a task:

- Press **ENTER** key.

To Enter a New Value in a Screen:

- Press **ENTER** key and **ESCAPE** key at the same time.

To change language

- Press **LANGUAGE** key.

Footnotes:

¹When Delayed Cold Start is set to ON, controller shows "dELAY / AC" screen and alternator output remains off until engine temperature increases to 32 C (90 F).

²"RESTART IN XX MIN." screen indicates controller has stopped unit operation due to an alarm. Controller will attempt to restart unit in the time shown.

STANDARD DISPLAY



MAIN MENU

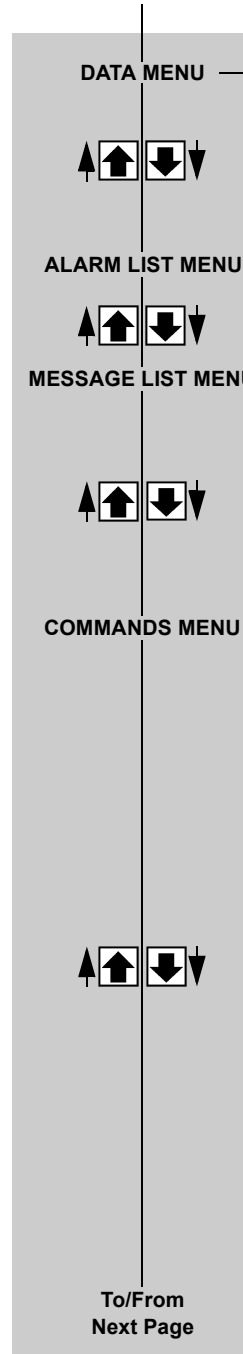

CONTROLLER MENU GUIDE

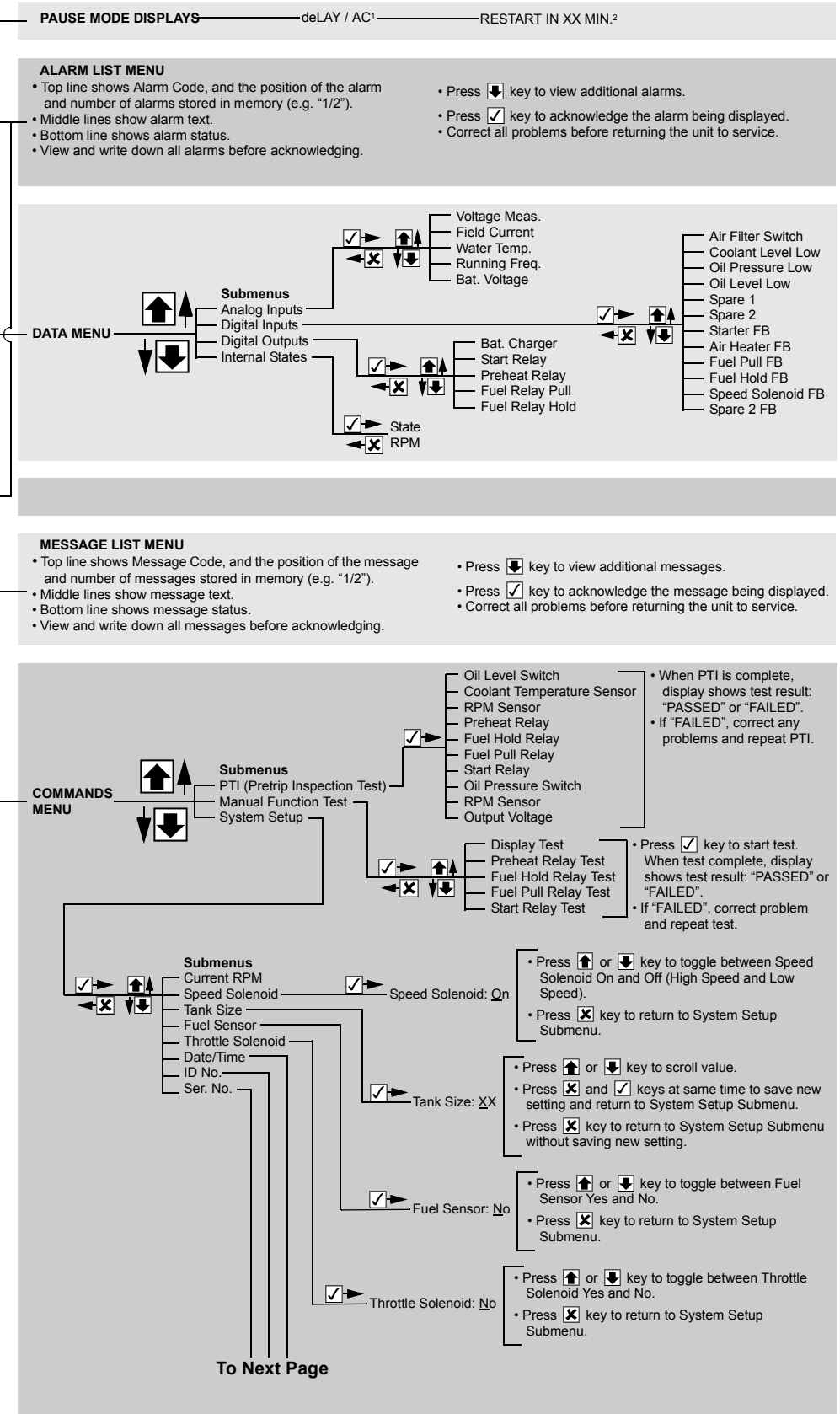

CONTROLLER MENU GUIDE (Continued)

